



**READ THIS MANUAL CAREFULLY!**

# **OWNER'S MANUAL**

***Y65-250***

## TABLE OF CONTENTS

LOCATION OF THE WARNING AND SPECIFICATION OF LABELS.....	1-1	Adjusting the rear shock absorber Assembly.....	4-9
SAFETY INFORMATION.....	2-1	PRE-OPERATION CHECKS.....	5-1
DESCRIPTION.....	3-1	Fuel.....	5-3
Left view.....	3-1	Engine oil.....	5-3
Right view.....	3-1	Radiator.....	5-3
Control and instruments.....	3-2	Front and rear brakes.....	5-3
INSTRUMENT AND CONTROL FUNCTIONS.....	4-1	Throttle lever.....	5-3
Main switch.....	4-1	Drive chain.....	5-3
Indicator light.....	4-1	Tires.....	5-3
Handlebar switches.....	4-2	Chassis fasteners.....	5-5
Throttle lever.....	4-3	Instrument, lights and switches.....	5-5
Speed limiter.....	4-3	OPERATION.....	6-1
Clutch lever.....	4-4	Starting a cold engine.....	6-1
Brake lever.....	4-4	Starting a warm engine.....	6-1
Brake pedal.....	4-4	Shifting.....	6-2
Shift pedal.....	4-5	Engine break-in.....	6-3
Fuel tank cap.....	4-5	Parking on a slope.....	6-4
Fuel.....	4-5	Accessories and loading.....	6-4
Fuel cock.....	4-6	RIDING YOUR ATV.....	7-1
Seat.....	4-8	GETTING TO KNOW YOUR ATV.....	7-2
Adjusting the front shock absorber Assemblies.....	4-9	RIDE WITH CARE AND GOOD JUDGMENT.....	7-2
		BE CAREFUL WHERE YOU RIDE.....	7-8
		TURNING YOUR ATV.....	7-11

CLIMBING UPHILL.....	7-12	Checking the brake pedal height.....	8-17
RIDING DOWNHILL.....	7-14	Adjusting the clutch lever free play.....	8-17
CROSSING A SLOPE.....	7-15	Drive chain slack.....	8-18
CROSSING THROUGH SHALLOW WATER.....	7-16	Lubricating the drive chain.....	8-19
RIDING OVER ROUGH TERRAIN.....	7-17	Checking and lubricating the cables.....	8-20
SLIDING AND SKIDDING.....	7-17	Checking and lubricating the brake and Clutch levers.....	8-20
WHAT TO DO IF.....	7-18	Checking the shift pedal.....	8-21
WHAT TO DO.....	7-18	Checking and lubricating the brake Pedal.....	8-21
PERIODIC MAINTENANCE AND ADJUSTMENT.....	8-1	Checking the wheel hub bearings.....	8-21
Owner's manual and tool kit.....	8-2	Lubricating the swingarm pivots.....	8-21
Periodic maintenance chart for the emission control system.....	8-3	Lubricating the upper and lower arm Pivots.....	8-21
General maintenance and lubrication chart.....	8-4	Lubricating the steering shaft.....	8-22
Checking the spark plug.....	8-7	Battery.....	8-22
Engine oil and oil filter element.....	8-9	Replacing the fuse.....	8-24
Cleaning the air filter element.....	8-11	Replacing a headlight bulb.....	8-25
Adjusting the carburetor.....	8-14	Adjusting a headlight beam.....	8-26
Adjusting the engine idling speed.....	8-14	Relacing the tail/brake light bulb.....	8-27
Adjusting the throttle lever free play.....	8-15	Removing a wheel.....	8-27
Valve clearance.....	8-15	Installing a wheel.....	8-28
Brakes.....	8-15	Troubleshooting.....	8-28
Checking the front and rear brake pads.....	8-15	Troubleshooting chart.....	8-29
Checking the brake fluid level.....	8-16	CLEANING AND STORAGE.....	9-1
Changing the brake fluid.....	8-16	Cleaning.....	9-1
Checking the front brake lever free play .....	8-17	Storage.....	9-2
		SPECIFICATIONS.....	10-1

## LOCATION OF THE WARNING AND SPECIFICATION LABELS

Read and understand all of the labels on your ATV. These labels contain important information for safe and proper operation. Never remove any labels from your ATV. If a label become difficult to read or comes off, request a replacement label from your dealer.

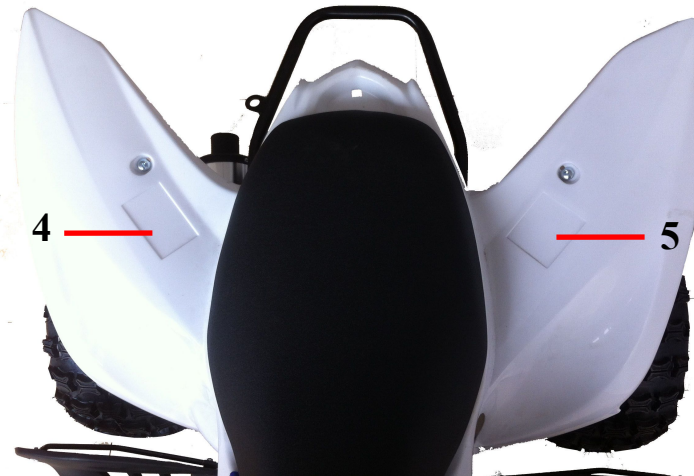

1

**Warning**

Must wear the certified helmet and protective equipment

Ban on the roads

Ban to pick up passengers

Banned alcohol, drugs and driving

The following situations are forbidden to drive:

- Without the right training or not read product specifications
- Beyond the driver skills of speeding
- Road-can result in and other vehicle collisions
- Manned- -this will affect the balance of the vehicle and driving, lead to dangerous driving out of control

Driving:

- Use the right driving technology, in order to avoid all terrain vehicle in the hills and muddy road
- Avoid on the road-path will be the serious influence manipulation and control

Please find and reading product specifications, abide by manipulating directives and warning

2

**Warning**

Banned driving under the age of 16 children.

Children under the age of 16 driving this car has the risk of severely injured or death.

Banned driving under the age of 16 children and teenager.

3

**Warning**

Please use 90 # gasoline

Refueling should be flamed out, to prevent fire or explosion hazard.

4

**Warning**

Inaccurate tyre pressure or overloading will lead to the motorcycle out of control.

Out of control will lead to serious injure or death.

.The tyre pressure of cold state:

Front:60kpa±5kpa

Rear:60kpa±5kpa

. Max load weight: 60kg

5.

**Warning**

Ban to pick up passengers.

If to pick up passengers can lead to uncontrollability, cause serious injury or death.

Familiarize yourself with the following pictograms and read the explanatory text, then make sure to check the pictograms that apply to your model.

	ALWAYS use an approved helmet and Protective gear
---	---

	NEVER use on paved roads.
---	---------------------------

	NEVER carry passengers.
--	-------------------------

	NEVER use with drugs or alcohol.
---	----------------------------------

	NEVER operate this ATV if you are under age of 16. Operating this ATV if you are under the age of 16 increases your chance of severe injury or death.
---	--



## SAFETY INFORMATION

### AN ATV IS NOT A TOY AND CAN BE HAZARDOUS TO OPERATE.

An ATV handles differently from other vehicles, including motorcycles and cars. A collision or roll-over can occur quickly, even during routine maneuvers such as turning and riding on hills or over obstacles, if you fail to take proper precautions.

SEVERE INJURY OR DEATH can result if you do not follow these instructions:

- Read this manual and all labels carefully and follow the operating procedures described.
- Never operate an ATV without proper training or instruction.
- Always follow the age recommendation:
  - A child under 16 years old should never operate an ATV with engine size greater than 90 cc.
- Never allow a child under age 16 to operate an ATV without adult supervision, and never allow continued use of an ATV by a child if he or she does not have the abilities to operate it safely.
- Never carry a passenger on an ATV.
- Always avoid operating an ATV on any paved surfaces, including sidewalks, driveways, parking lots and paved streets.
- Never operate an ATV on any paved street, paved road or motorway.
- Watch carefully for other vehicles when operating on unpaved public streets or roads. Make sure you know your country's laws and regulations before you ride on unpaved public streets or roads.
- Never operate an ATV without wearing an approved motorcycle helmet that fits properly. You should also wear eye protection (goggles or face shield), gloves, boots, a long-sleeved shirt or a jacket, and long pants.
- Never consume alcohol or drugs before or while operating this ATV.
- Never operate at speeds too fast for your skills or the riding conditions. Always go at a speed that is proper for the terrain, visibility, operating conditions, and your experience.
- Never attempt wheelies, jumps, or other stunts.
- Always inspect your ATV each time you use it to make sure it is in safe operating condition. Always follow the inspections and maintenance procedures and schedules described in this manual.
- Always keep both hands on the handlebars and both feet on the footrest of the ATV during operation.
- Always go slowly and be extra careful when operating on unfamiliar terrain. Always be alert to changing terrain conditions when operating the ATV.
- Never operate on excessively rough, slippery or loose terrain until you have learned and practiced the skills necessary to control the ATV on such terrain. Always be especially cautious on these kinds of terrain.
- Always follow proper procedures for turning as described in this manual. Practice turning at low speeds before attempting to turn at faster speeds and never turn at excessive speeds.
- Never operate the ATV on hills too steep for the ATV or for your abilities. Practice on smaller hills before attempting larger hills.

- Always follow proper procedures for climbing hills as described in this manual. Check the terrain carefully before you start up any hill. Never climb hills with excessively slippery or loose surfaces. Shift your weight forward. Never open the throttle suddenly or make sudden gear changes.  
Never go over the top of a hill at a high speed.
- Always follow proper procedures for going down hills and for braking on hills as described in this manual. Check the terrain carefully before you start down any hill. Shift your weight backward. Never go down a hill at high speed. Avoid going down a hill at an angle that would cause the vehicle to lean sharply to one side. Go straight down the hill where possible.
- Always follow proper procedures for crossing the side of a hill as described in this manual.  
Avoid hills with excessively slippery or loose surfaces. Shift your weight to the uphill side of the ATV. Never attempt to turn the ATV around on any hill until you have mastered the turning technique described in this manual on level ground. Avoid crossing the side of a steep hill if possible.
- Always use proper procedures if you stall or roll backwards when climbing a hill. To avoid stalling, use the proper gear and maintain a steady speed when climbing a hill. If you stall or roll backwards, follow the special procedure for braking described in this manual. Dismount on the uphill side of to a side if pointed straight uphill. Turn the ATV around and remount, following the procedure described in this manual.
- Always check for obstacles before operating in a new area.
- Never attempt to operate over large obstacles, such as large rocks or fallen trees. Always follow proper procedures when operating over obstacles as described in this manual.
- Always be careful when skidding or sliding. Learn to safety control skidding or sliding by practicing at low speeds and on level, smooth terrain. On extremely slippery surfaces, such as ice, go slowly and be very cautious in order to reduce the change of skidding or sliding out of control.
- Never operate an ATV in fast flowing water or in water deeper than that recommended in this manual. Remember that wet brakes may have reduced stopping ability. Test your brakes after leaving water. If necessary, apply them several times to let friction dry out the linings.
- Always use the size and type of tires specified in this manual.
- Always maintain proper tire pressure as described in this manual.
- Never modify an ATV through improper installation or use of accessories.
- Never exceed the stated load capacity for an ATV. Cargo should be properly distributed and securely attached. Reduce speed and follow instructions in this manual for carrying cargo or pulling a trailer. Allow greater distance for braking.



## **WARNING**

### **Avoid Carbon Monoxide Poisoning**

All engine exhaust contains carbon monoxide, a deadly gas. Breathing carbon monoxide can cause headaches, dizziness, drowsiness, nausea, confusion, and eventually death. Carbon Monoxide is a colorless, odorless, tasteless gas which may be present even if you do not see or smell any engine exhaust. Deadly levels of carbon monoxide can collect rapidly and you can quickly be overcome and unable to save yourself. Also, deadly levels of carbon monoxide can linger for hours or days in enclosed or poorly ventilated areas. If you experience any symptoms of carbon monoxide poisoning, leave the area immediately, get fresh air, and **SEEK MEDICAL TREATMENT.**

- **Do not run engine indoors. Even if you try to ventilate engine exhaust with fans or open windows and doors, carbon monoxide can rapidly reach dangerous levels.**
- **Do not run engine in poorly ventilated or partially enclosed areas such as barns, garages, or carports.**
- **Do not run engine outdoors where engine exhaust can be drawn into a building through openings such as windows and Doors.**



## **WARNING**

**When transporting the ATV in another vehicle, be sure it is kept upright and that the fuel cock is in the “OFF” position. Otherwise, fuel may leak out of the carburetor or fuel tank.**

## DESCRIPTION

### Left view

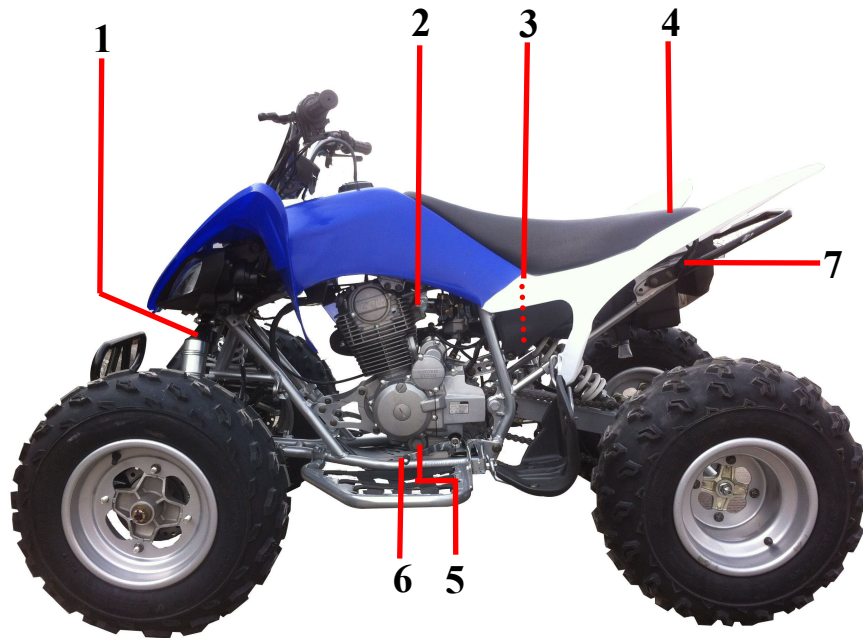

1. Front shock absorber assembly spring preload adjusting
2. Fuel cock
3. Rear shock absorber assembly spring preload adjusting
4. Owner's tool kit
5. Engine oil drain bolt
6. Shift pedal
7. Air filter

### Right view

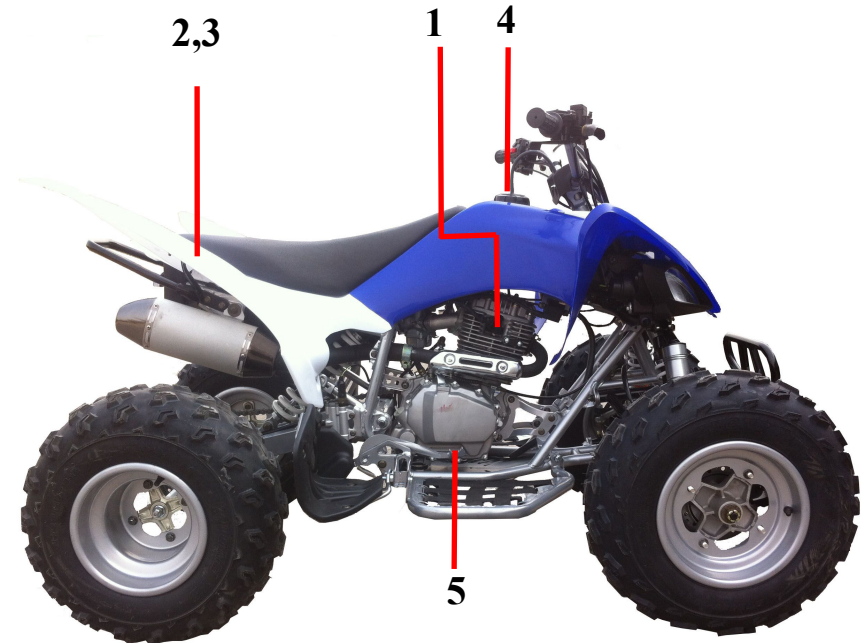

1. Spark plug
2. Fuse
3. Battery
4. Fuel tank cap
5. Brake pedal

## Controls and instruments



1. Clutch lever
2. Handlebar switches
3. Main switch
4. Front brake fluid reservoir
5. Throttle lever
6. Brake lever

### **TIP**

The ATV you have purchased may differ slightly from the figures shown in this manual.

## INSTRUMENT AND CONTROL FUNCTIONS

### MAIN SWITCH

The positions of the main switch are as follows:

#### ON

All electrical systems are supplied with power. The headlights and taillight come on when the light switch is on, and the engine can be started. The key cannot be removed.

#### OFF

All electrical systems are off. The key can be removed.

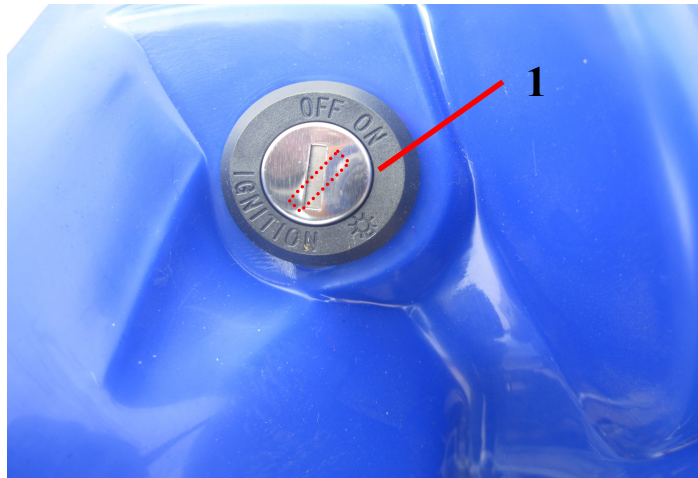

1. Main switch

### Indicator light



1. Neutral indicator light "N"
2. Reverse indicator light "R"

#### Neutral indicator light "N"

This indicator light comes on when the transmission is in the neutral position.

#### Reverse indicator light "R"

This indicator light comes on when the transmission is in the reverse position.

## Handlebar switches



1. Front light switch 

2. Light beam switch “/”

3. Engine stop switch “/”

4. Start switch “”

5.choke switch “”

**Engine stop switch** “/”

Set this switch to “” before starting the engine.



The engine stop switch controls the ignition and stops the engine when it is running. Use this switch to stop the engine in an emergency situation. The

engine will not start or run when this switch is set to “”.

**Start switch** “”

Push this switch to crank the engine with the starter. See the starting instructions prior to starting the engine.

**Light beam switch** “/”

Set this switch to “” to turn on the low beams and the taillight. Set the switch to “” to turn on the high beams and the taillight.

**Choke switch** “”

Starting a cold engine requires a richer air-fuel mixture, Which is supplied by the choke.

Move the choke switch to left to turn on the choke, move the choke to right to turn off the choke.

### **Notice**

**Do not use the headlights with the engine turned off for an extended period of time, otherwise the battery may discharge to the point that the starter motor will not operate properly. If this should happen, remove the battery and recharge it.**

## Throttle lever

Once the engine is running, pushing the throttle lever will increase the engine speed.

Regulated the speed of the ATV by varying the throttle position. Because the throttle is spring loaded, the ATV will decelerate, and the engine will return to an idle any time the throttle lever is released.

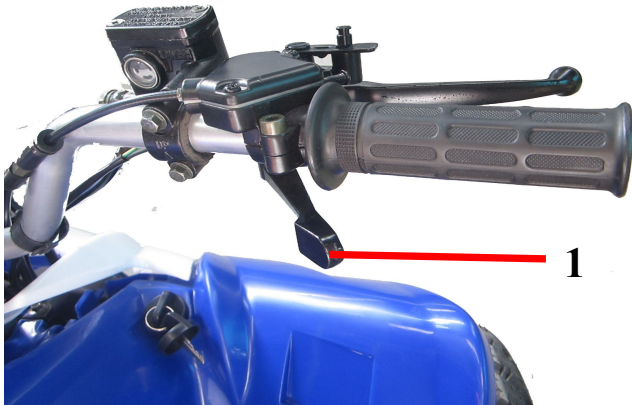

1. Throttle lever

Before starting the engine, check the throttle to be sure it is operating smoothly. Make sure it returns to the idle position as soon as the lever is released.

## Speed limiter

Your ATV is equipped with an adjustable speed limiter. The speed limiter keeps the throttle from fully opening, even when the throttle lever is pushed to maximum.

1. Loosen the locknut.
2. To increase the maximum engine power available and the maximum speed of the ATV, turn the adjusting screw counter-clockwise. To decrease the maximum engine power available and the maximum speed of the ATV, turn the adjusting screw clockwise. Do not turn the adjusting screw out more than 12 mm (0.47 in) or the throttle cable could be damaged. Always make sure the throttle lever free play is adjusted to 2.0-4.0 mm (0.08-0.16 in).

**WARNING! Improper adjustment of the speed limiter and throttle could cause throttle cable damage or improper throttle operation. You could lose control, resulting in an accident.**



1. Locknut
  2. Adjusting screw
  3. No more than 12 mm(0.47 in)
3. Tighten the locknut.

### Clutch lever

The clutch lever is located on the left handlebar and the ignition circuit cut-off system is incorporated in the clutch lever holder. To disengage the clutch, pull the clutch lever toward the handlebar grip. To engage the clutch, release the clutch lever. The clutch lever should be pulled rapidly and released slowly for smooth clutch operation. (See page 6-1 for a description of the ignition circuit cut-off system.)



1. Clutch lever

### Brake lever

The brake lever is located at the right handlebar grip. To apply the front brake, pull the brake lever toward the handle grip.



1. Brake lever

### Brake pedal

The brake pedal is located on the right side of the ATV. To apply the rear brake, push down on the brake pedal.

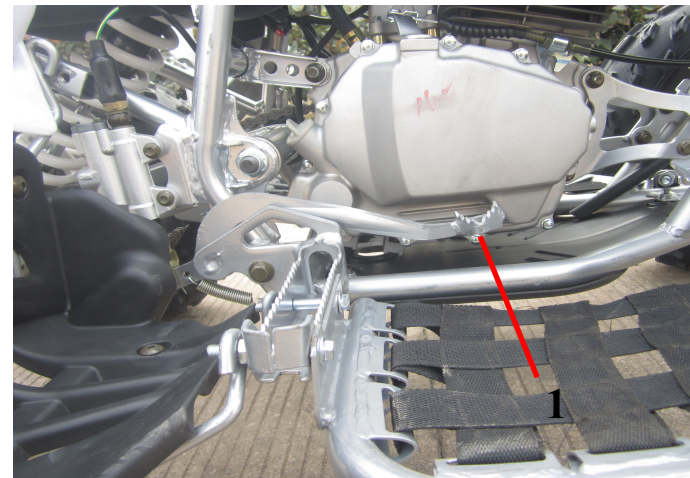

1. Brake pedal

### Shift pedal

This ATV is equipped with a constant-mesh 4-speed transmission. The shift pedal is located on the left side of the engine and is used in combination with the clutch when shifting.

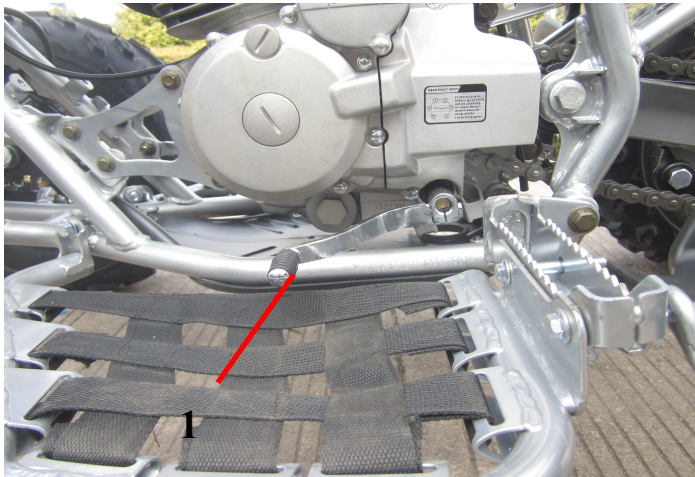

1. Shift pedal

### Fuel tank cap

Remove the fuel tank cap by turning it counter-clockwise.

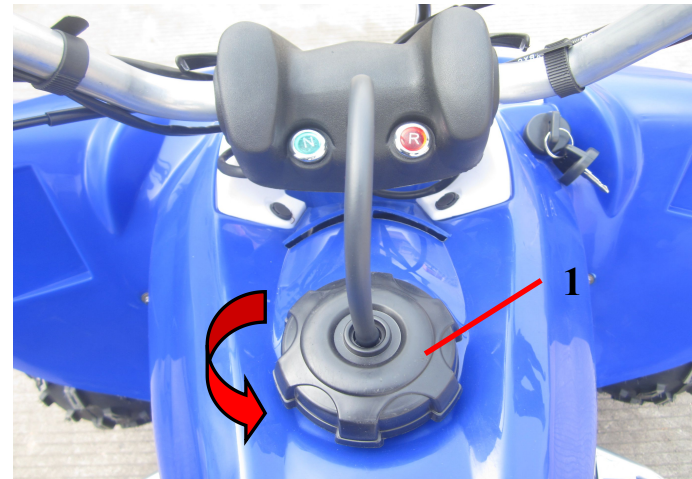

1. Fuel tank cap

### Fuel

Make sure there is sufficient gasoline in the tank.

#### **WARNING**

**Gasoline and gasoline vapors are extremely flammable. To avoid fires and explosions and to reduce the risk of injury when refueling, follow these instructions.**

1. Before refueling, turn off the engine and be sure that no one is sitting on the vehicle. Never refuel while smoking, or while in the vicinity of sparks, open flames, or other sources of ignition such as the pilot lights of water heaters and clothes dryers.
2. Do not overfill the fuel tank. When refueling, be sure to insert the pump nozzle into the fuel tank filler hole.

Stop filling when the fuel reaches the bottom of the filter tube. Because fuel expands when it heats up, heat from the engine or the sun can cause fuel to spill out of the fuel tank.

3. Wipe up any spilled fuel immediately.  
**NOTICE: Immediately wipe off spilled fuel with a clean, dry, soft cloth, since fuel may deteriorate painted surfaces or plastic parts.**
4. Turn the fuel tank cap fully clockwise to make sure it is securely closed.

#### **WARNING**

**Gasoline is poisonous and then cause injury or death. Handle gasoline with care. Never siphon gasoline by mouth. If you should swallow some gasoline or inhale a lot of gasoline vapor, or get some gasoline in your eyes, see your doctor immediately. If gasoline spills on your skin, wash with soap and water. If gasoline spills on your clothing, change your clothes.**

#### **NOTICE**

**Use only unleaded gasoline. The use of leaded gasoline will cause severe damage to internal engine parts, such as the valves and piston rings, as well as to the exhaust system.**

#### **Fuel cock**

The fuel cock supplies fuel from the tank to the carburetor while also filtering it.

The fuel cock lever positions are explained as follows and shown in the illustrations.

#### **OFF**

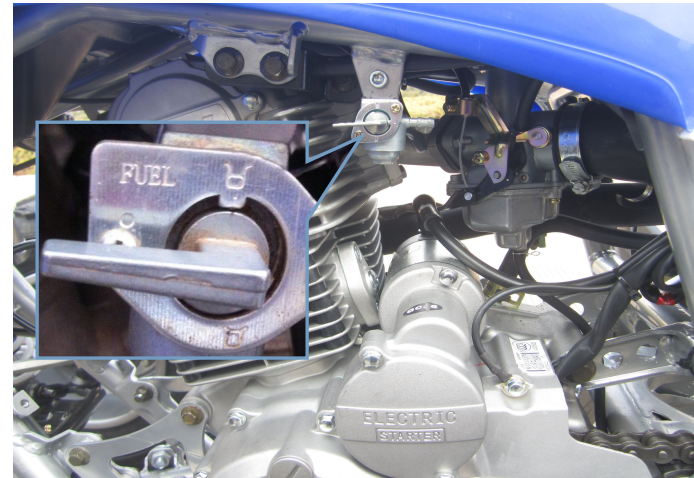

1. Arrow mark positioned over "OFF"

With the fuel cock lever in this position, fuel will not flow. Always turn the fuel cock lever to this position when the engine is not running.

## ON

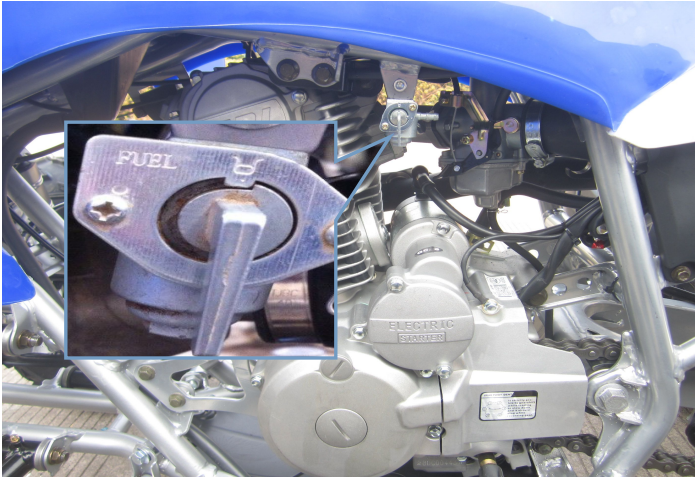

1. Arrow mark positioned over "ON"

With the fuel cock lever in this position, fuel flows to the carburetor. Turn the fuel cock lever to this position when starting the engine and riding.

## RES



1. Arrow mark positioned over "RES"

This indicates reserve. With the fuel cock lever in this position, the fuel reserve is made available. Turn the fuel cock lever to this position if you run out of fuel while riding. When this occurs, refuel as soon as possible and be sure to turn the fuel cock lever back to "ON"

## Seat

### To remove the seat

Insert your hand between the rear of the seat and the rear fender, pull the seat lock lever upward and pull up the seat at the rear.



1. Seat lock lever

### To install the seat

Insert the projections on the front of the seat into the seat holders and push down on the seat at the rear. Make sure that the seat is securely fitted.

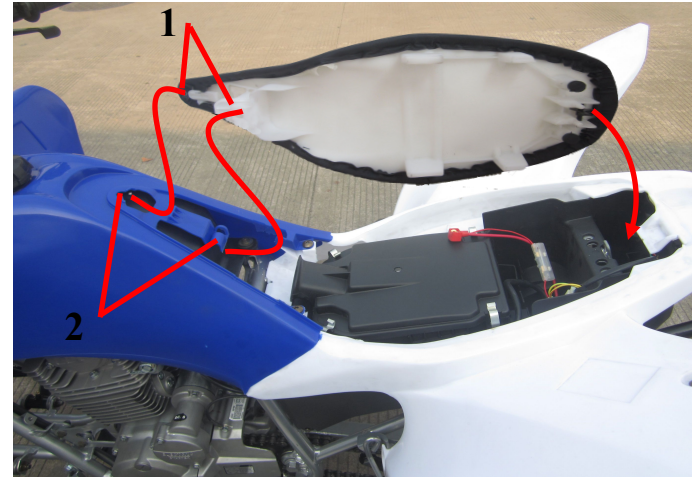

1. Projection  
2. Seat holder

### Adjusting the front shock absorber assemblies

The spring preload can be adjusted to suit the rider's weight and the riding conditions.

#### **WARNING**

**Always adjust the shock absorber assemblies on the left and right side to the same setting. Uneven adjustment can cause poor handling and loss of stability, which could lead to an accident.**

Adjust the spring preload as follows.

Turn the spring preload adjusting ring clockwise to increase the spring preload and thereby harden the suspension, and turn counter-clockwise to decrease the spring preload and thereby soften the suspension.



1. Spring preload adjusting ring

### Adjusting the rear shock absorber assembly

The spring preload can be adjusted to suit the rider's weight and the riding conditions.

#### **NOTICE**

**Never turn the adjusting mechanism beyond the minimum and maximum settings.**

Adjust the spring preload as follows.

Turn the spring preload adjusting ring clockwise to increase the spring preload and thereby harden the suspension, and turn counter-clockwise to decrease the spring preload and thereby soften the suspension.

Normally adjust the spring soft or hard by adjusting the shortcut adjuster knob, turn clockwise to harden the spring, and turn counter-clockwise to soften the spring.

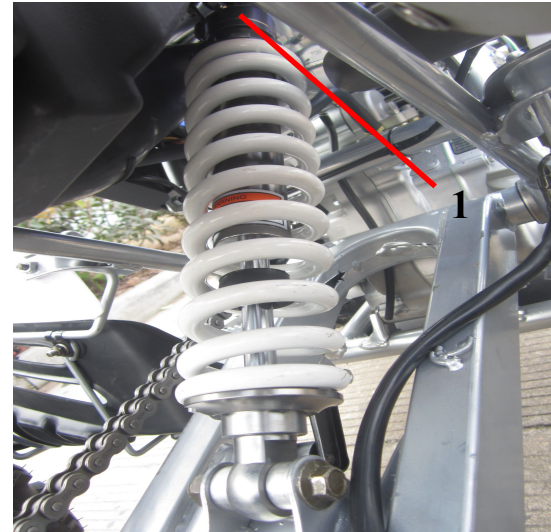

1. Spring preload adjusting ring

## **WARNING**

**This shock absorber assembly contains highly pressurized nitrogen gas. If the shock absorber assembly is damaged, it could explode causing injury or property damage. Shock absorber cylinder damage could also result in poor handling which could cause an accident.**

- **Do not tamper with or attempt to open the cylinder assembly.**
- **Do not subject the shock absorber assembly to an open flame or other high heat.**
- **Do not deform or damage the cylinder in any way.**
- **Do not dispose of a damaged or worn out shock absorber assembly yourself. Take the shock absorber assembly to a dealer for any service.**

## PRE-OPERATION CHECKS

Inspect your vehicle each time you use it to make sure the vehicle is in safe operating condition. Always follow the inspection and maintenance procedures and schedules described in the owner's Manual.

### WARNING

**Failure to inspect or maintain the vehicle properly increases the possibility of an accident or equipment damage. Do not operate the vehicle if you find any problem.**

**if a problem cannot be corrected by the procedures provided in this manual, have the vehicle inspected by your dealer.**

Before using this vehicle, check the following points:

ITEM	ROUTINE
<b>Fuel</b>	<ul style="list-style-type: none"><li>● Check fuel level in fuel tank, and add recommended fuel if necessary.</li><li>● Check fuel line for leakage. Correct if necessary.</li></ul>
<b>Engine oil</b>	<ul style="list-style-type: none"><li>● Check oil level in engine, and add recommended oil to specified level if necessary.</li><li>● Check ATV for oil leakage. Correct if necessary.</li></ul>
<b>Radiator</b>	<ul style="list-style-type: none"><li>● Check colling liquid in radiator, and add colling liquid to the full.</li><li>● Check colling liquid for leakage. Correct if necessary.</li></ul>
<b>Front brake</b>	<ul style="list-style-type: none"><li>● Check operation. If soft or spongy, have a dealer bleed hydraulic system.</li><li>● Check brake pads for wear, and replace if necessary.</li><li>● Check brake fluid level in reservoir, and add specified brake fluid to specified level if necessary.</li><li>● Check hydraulic system for leakage. Correct if necessary.</li></ul>

ITEM	ROUTINE
<b>Rear brake</b>	<ul style="list-style-type: none"> <li>● Check operation. If soft or spongy, have a dealer bleed hydraulic system.</li> <li>● Check brake pads for water, and replace if necessary.</li> <li>● Check brake fluid level in reservoir, and add specified brake fluid to specified level if necessary.</li> <li>● Check hydraulic system for leakage. Correct if necessary.</li> </ul>
<b>Clutch</b>	<ul style="list-style-type: none"> <li>● Check operation, and correct if necessary.</li> <li>● Lubricate cable if necessary.</li> <li>● Check lever free play, and adjust if necessary.</li> </ul>
<b>Throttle lever</b>	<ul style="list-style-type: none"> <li>● Make sure that operation is smooth. Lubricate cable and lever housing if necessary.</li> <li>● Check lever free play, and adjust if necessary.</li> </ul>
<b>Control cables</b>	<ul style="list-style-type: none"> <li>● Make sure that operation is smooth. Lubricate if necessary.</li> </ul>
<b>Drive chain</b>	<ul style="list-style-type: none"> <li>● Check chain slack, and adjust if necessary.</li> <li>● Check chain condition. Lubricate if necessary.</li> </ul>
<b>Wheels and tires</b>	<ul style="list-style-type: none"> <li>● Check wheel condition, and replace if damaged.</li> <li>● Check tire condition and tread depth. Replace if necessary.</li> <li>● Check air pressure. Correct if necessary.</li> </ul>
<b>Shift pedal</b>	<ul style="list-style-type: none"> <li>● Make sure that operation is smooth.</li> <li>● Correct if necessary</li> </ul>
<b>Brake pedal</b>	<ul style="list-style-type: none"> <li>● Make sure that operation is smooth. Lubricate pedal pivoting point if necessary.</li> </ul>
<b>Brake and clutch levers</b>	<ul style="list-style-type: none"> <li>● Make sure that operation is smooth. Lubricate lever pivoting points if necessary.</li> </ul>
<b>Chassis fasteners</b>	<ul style="list-style-type: none"> <li>● Make sure that all nuts, bolts and screw are properly tightened.</li> </ul>
<b>Instruments, lights and switches</b>	<ul style="list-style-type: none"> <li>● Check operation, and correct if necessary.</li> </ul>

## **FUEL**

Make sure that there is sufficient fuel in the tank.

## **Engine oil**

Make sure that the engine oil is at the specified level.  
add oil as necessary.

## **Radiator**

Check the cooling fluid level if your ATV is water cooled engine, add fluid if necessary.

If add cooling liquid to full, start engine idle speed running, The liquid level will decline, then add the liquid gradually to full.

**Attention!** the liquid must be anti freezing colling liquid)

## **Front and rear brakes**

### **Brake lever and brake pedal**

- Check that there is no free play in the brake lever. If there is free play, have a dealer check the brake system.
- Check for correct brake pedal height. If the pedal height is incorrect, have a dealer adjust it.
- Check the operation of the lever and pedal. They should move smoothly and there should be a firm feeling when the brakes are applied. If not, have a dealer check the brake system.

### **Brake fluid level**

Check the brake fluid level. Add fluid if necessary.

### **Brake fluid leakage**

Check to see if any brake fluid is leaking out of the pipe joints or brake fluid reservoirs. Apply the brakes firmly for one minute. If there is any leakage, have a dealer check the brake system.

### **Brake operation**

Test the brakes at slow speed after starting out to make sure they are working properly. If the brakes do not provide proper braking performance, check the brake pads for wear.

### **Throttle lever**

Check the operation of the throttle lever. It must open smoothly and spring back to idle position when released. Have a dealer correct if necessary.

### **Drive chain**

Check the condition of the drive chain and check the drive chain slack. Lubricate and adjust the drive chain as necessary.

### **Tires**

Check tire pressure tire gauge to check and adjust tire pressure when the tires are cold. Tire pressures must be equal on both sides.

**WARNING! Operation of this vehicle with improper tire pressure may cause severe injury or death from loss of control or rollover. Tire pressure below the minimum specified could also cause the tire to dislodge from the rim under severe riding conditions.**

Set tire Pressures to the following specifications:

Recommended tire pressure:	
Front	27.5 kPa (0.275 kgf/cm <sup>2</sup> , 4.0 psi)
Rear	27.5 kPa (0.275 kgf/cm <sup>2</sup> , 4.0 psi)
Minimum tire pressure:	
Front	24.5 kPa (0.245 kgf/cm <sup>2</sup> , 3.6 psi)
Rear	24.5 kPa (0.245 kgf/cm <sup>2</sup> , 3.6 psi)
Maximum tire seating pressure:	
Front	250 kPa (2.5 kgf/cm <sup>2</sup> , 36 psi)
Rear	250 kPa (2.5 kgf/cm <sup>2</sup> , 36 psi)

The lower-pressure the gauge is included as standard equipment. Make two measurements of the tire pressure and use the second reading. Dust or dirt in the gauge could cause the first reading to be incorrect.

### Tire wear limit

When the tire groove decreases to 3 mm (0.12 in) due to wear, replace the tire.

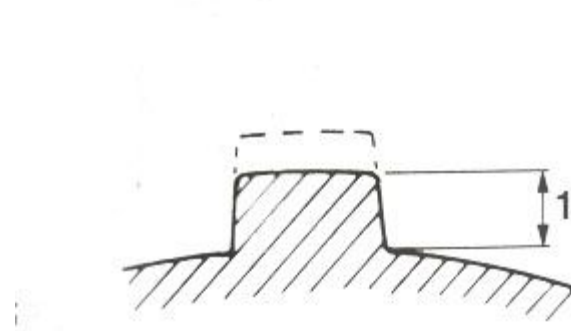

1. Tire wear limit

### Tire information

This ATV is equipped with tubeless tires with valves.

### WARNING

**Use of improper tires on this ATV may cause loss of control, increasing your risk of an accident.**

After extensive tests, only the tires listed below have been approved for this model.

Front:
Size:
AT20*7.0-10
Type:
Tubeless
Rear:
Size:
AT19*10-9
Type:
Tubeless

### **Chassis fasteners**

Make sure that all nuts, bolts and screws are properly tightened.

### **Instruments, lights and switches**

Check that all instruments, lights and switches are working properly. Correct if necessary.

### **Aftermarket tires and rims**

The tires and rims that came with your ATV were designed to match the performance capabilities and to provide the best combination of handling, braking, and comfort. Other tires, rims, sizes, and combinations may not be appropriate.

## OPERATION

Read the owner's Manual carefully before riding the ATV. If there is a control or function you do not understand, ask your dealer.

### WARNING

**Read the Owner's Manual carefully to become familiar with all controls in order to help prevent any loss of control, which could cause an accident or injury.**

### Starting a cold engine

#### **NOTICE**

**See the " Engine break-in" section prior to operating the engine for the first time.**

1. Turn the fuel cock to "ON".
2. Turn the key to "ON" and the engine stop

Switch to .

3. Shift the transmission into neutral. The neutral Indicator light should come on. If the indicator lights does not come on, have a dealer check the electrical circuit.

### TIP

This model is equipped with an ignition circuit cutoff system. The engine can be started under the following conditions.

- The transmission is in neutral
- The clutch is disengaged with the transmission in gear. However, it is recommended to shift into Neutral before starting the engine.

4. Completely close the throttle lever and start the engine by pushing the start switch.

### TIP

If the engine fails to start, release the start switch, then push it again. Pause a few seconds before the next attempt. Each cranking should be as short as possible to preserve battery energy. Do not crank the engine more than 10 seconds on each attempt.

#### **NOTICE**

**For maximum engine life, never accelerate hard when the engine is cold!**

### Starting a warm engine

Follow the same procedures as for starting a cold engine. Instead, start the engine with the throttle slightly open.

## Shifting

This ATV has a 4-speed forward transmission. The transmission allows you to control the amount of power you have available at a given speed or for starting, accelerating, climbing hills, etc.

To shift into neutral, release the throttle lever, apply the clutch, and then repeatedly depress the shift pedal until it stops. When it stops, it will be in first gear. Raise the pedal slightly to reach the neutral position, and then release the clutch.

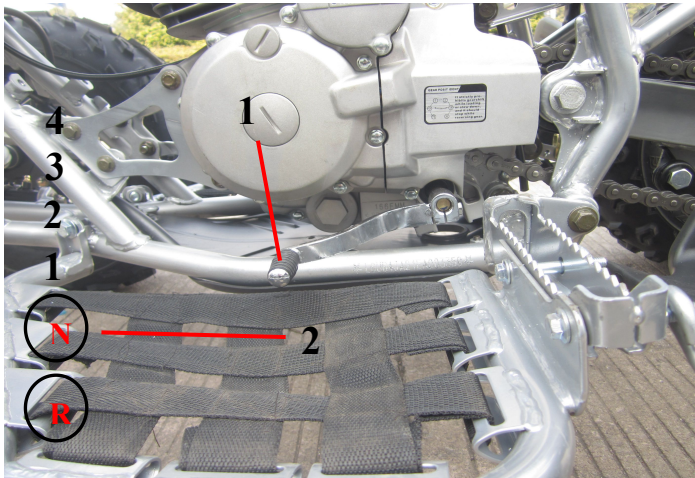

1. Shift pedal
2. Neutral position

## To start out and accelerate

1. Release the throttle lever, apply the front or rear brake

### **NOTICE**

**Always close the throttle before shifting gears, otherwise damage to the engine and drive train may result.**

2. Pull the clutch lever to disengage the clutch.
3. Shift into first gear, and then release the brake.
4. Open the throttle gradually and at the same time, release the clutch lever slowly.

**WARNING! Opening the throttle abruptly or releasing the clutch lever too quickly could make the ATV wheelie, which would increase the change of an accident, including an overturn.**

5. Once the ATV has attained adequate speed, release the throttle, and at the same time, quickly pull in the clutch lever.
6. Shift the transmission into second gear.  
(Make sure not to shift the transmission into Neutral.)
7. Open the throttle parts way and gradually release the clutch lever.
8. Follow the same procedure when shifting to the next higher gear.

### **To decelerate**

When slowing down or stopping, release the throttle and apply the brakes smoothly and evenly. As you slow down, shift to a lower gear. Be sure that the engine has sufficiently slowed before engaging a lower gear. Improper use of the brakes or shifting can cause the tires to lose traction, reducing control and increasing the possibility of an accident.

### **WARNING**

**Make sure the engine has sufficiently slowed before shifting to a lower gear. Engaging a lower gear when the engine speed is too high could make the wheel stop rotating and lose traction. This could cause loss of control, an accident and injury. It could also cause engine or drive train damage.**

### **NOTICE**

- **Even with the transmission in the neutral position, do not coast for long periods of time with the engine off, and do not tow the ATV for long distance. The transmission is properly lubricated only when the engine is running. Inadequate lubrication may damage the transmission.**
- **Always use the clutch when changing gears. The engine, transmission and drive train are not designed to withstand the shock of forced shifting and can be damaged by shifting without using the clutch.**

## **Engine break-in**

### **TIP**

- For ATVs equipped with an odometer or an hour meter, follow the figures given in km (mi) or the figures given in hours.
- For ATVs not equipped with an odometer or hour meter, follow the figures given in hours. There is never a more important period in the life of your engine than the first 320 km (200 mi) or 20 hours of riding. For this reason, you should read the following material carefully. Since the engine is brand new, do not put an excessive load on it for the first 320 km (200 mi) or 20 hours. The various parts in the engine wear and polish themselves to the correct operating clearances. During this period, prolonged full-throttle operation or any condition that might result in engine overheating must be avoided.

### **0-160 km (0-100 mi) or 0-10 hours**

Avoid prolonged operation above 1/2 throttle. Vary the speed of the ATV regularly. Do not operate it at one set throttle position.

### **160-320 km (100-200 mi) or 10-20 hours**

Avoid prolonged operation above 3/4 throttle. Rev the engine through the gears freely, but do not use full throttle at any time.

### **320 km (200 mi) or 20 hours and beyond**

The ATV can now be operated normally.

## **NOTICE**

If any engine trouble should occur during the engine break-in period, immediately have a dealer check the ATV.

## **Parking on a slope**

### **WARNING**

Avoid parking on hills or other inclines. Parking on a hill or other incline could cause the ATV to roll out of control, increasing the chance of an accident. If you must park on an incline, place the ATV transversely across the incline, shift into first gear, stop the engine, and then block the front and rear wheels with rocks or other objects. **Never park the ATV on hills that are too steep to walk up easily.**

1. Bring the ATV to a stop by applying the front brake, shift into first gear, and then stop the engine.
2. Releasing the front and rear brakes.
3. Turn the fuel cock to "OFF"

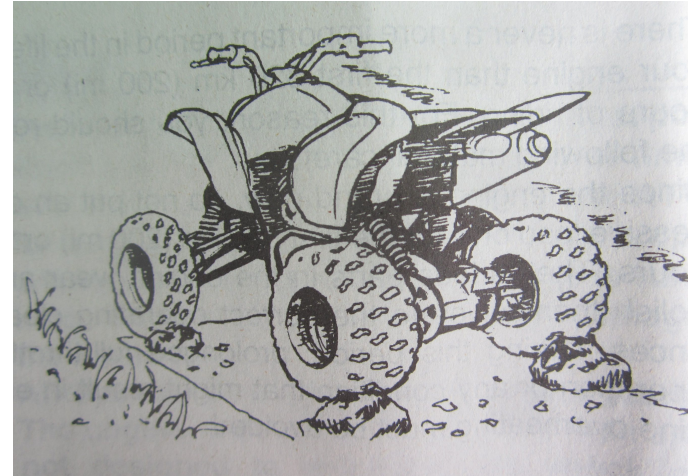

### **Accessories and loading Original Accessories**

Choosing accessories for your ATV is an important decision. Original Accessories, which are available only from your dealer, have been designed, tested, and approved for use on your ATV.

### **Aftermarket parts, accessories, and modifications**

While you may find aftermarket products similar in design and quality to Original Accessories, recognize that some aftermarket accessories or modifications are not suitable because of potential safety hazards to you or others. Installing after-market products or having other modifications performed to your ATV that change any of the vehicle's design or operation characteristics can put you and others at greater risk of serious injury or death. You are responsible for injuries related to change in the vehicle.

Keep the following in mind when considering an accessory or operating an ATV which has accessories.

- Accessories should be rigidly and securely mounted. An accessory which can shift position or come off while you are riding could affect your ability to control the ATV.
- Do not mount an accessory where it could interfere with your ability to control the ATV. Examples include (but are not limited to ) a heavy or bulky object attached to the handlebars which could make steering difficult, an accessory that limits your ability to move around on the seat, or one that limits your view.
- Use extra caution when riding an ATV with accessories. The ATV may handle differently than it does without accessories.

### Loading

#### **WARNIGN**

**Never exceed the stated load capacity for this ATV. Overloading this ATV or carrying or towing cargo improperly could cause changes in ATV handling which could lead to an accident.**

**Cargo should be properly distributed and securely attached. Reduced speed when carrying cargo or pulling a trailer. Allow greater distance for braking.**

As originally equipped, this ATV is not designed to carry cargo or tow a trailer. If you choose to add accessories so that you can carry cargo or tow a trailer, you must use common sense and good judgment as the stability and handling of an ATV can be

changed. When adding accessories, keep the following points in mind:

- Never exceed the weight limits shown. An overloaded ATV can be unstable.

#### MAXIMUM LOADING LIMIT

ATV loading limit (total weight of rider, cargo, accessories, and tongue):

100kg

- If you are carrying cargo and towing a trailer, include the tongue weight in the maximum ATV load limit.
- Load cargo on the carries as close to the center of the ATV as possible. Put cargo at the rear of the front carrier, at the front of the rear carrier, and center it.
- Tie down cargo securely to the carries. Make sure cargo in the trailer cannot move around. A shifting load can cause an accident.
- Make sure the load does not interfere with controls or your ability to see where you are going.
- Ride more slowly than you would without a load. The more weight you carry, the slower you should go. Although conditions vary, it is good

Practice not to exceed 2nd gear whenever you are carrying heavier loads or when towing a trailer.

- Allow more braking distance. A heavier ATV takes longer to stop.
- Avoid making sharp turns unless at vary slow speeds.
- Avoid hills and rough terrain. Choose terrain carefully. Added weight affects the stability and handling of the ATV.

## RIDING YOUR ATV

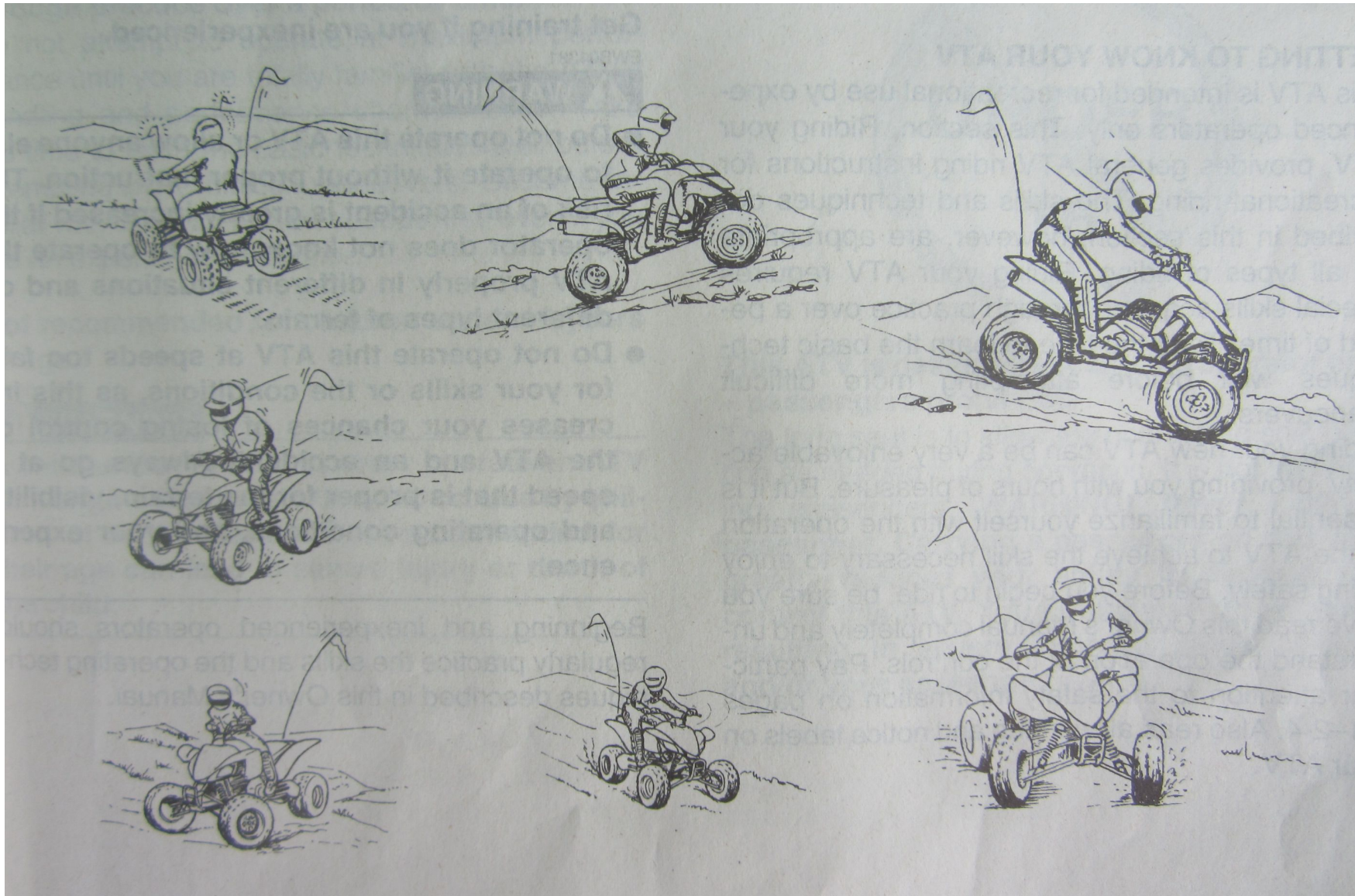

## GETTING TO KNOW YOUR ATV

This ATV is intended for recreational use by experienced operators only. This section, Riding your ATV, provides general ATV riding instructions for recreational riding.

The skills and techniques described in this section, however, are appropriate for all types of riding.

Riding your ATV requires special skills acquired through practice over a period of time. Take the time to learn the basic techniques well before attempting more difficult maneuvers.

Riding your new ATV can be a very enjoyable activity, providing you with hours of pleasure. But it is essential to familiarize yourself with the operation of the ATV to achieve the skill necessary to enjoy riding safely. Before you begin to ride, be sure you have read this Owner's Manual completely and understand the operation of the controls. Pay particular attention to the safety information. Also read all warning and notice labels on your ATV.

## RIDE WITH CARE AND GOOD JUDGMENT

**Get training if you are inexperienced.**

### WARNING

- **Do not operate this ATV or allow anyone else to operate it without proper instruction. The risk of an accident is greatly increased if the operator does not know how to operate the ATV properly in different situations and on different types of terrain.**
- **Do not operate this ATV at speeds too fast for your skills or the conditions, as this increases your chances of losing control of the ATV and accident. Always go at a speed that is proper for the terrain, visibility and operating conditions, and your experience.**

Beginning and inexperienced operators should regularly practice the skills and the operating techniques described in this Owner's Manual.

**Riding your ATV requires skills acquired through practice over a period of time.**

Do not attempt to operate at maximum performance until you are totally familiar with the ATV's handling and performance characteristics. Take the time to learn the basic techniques well before attempting more difficult maneuvers. Become familiar with this ATV at slow speeds first, even if you are an experienced operator.

**Not recommended for children under 16 years of age.**

**WARNING**

**A child under 16 should never operate an ATV with engine size greater than 90 cc. Use by children of ATVs that are not recommended for their age can lead to severe injury or death of the child.**



**This ATV is designed to carry the operator only —passengers prohibited.**

The long seat is to allow the operator to shift position as needed during operation. It is not for carrying passengers. **WARNING! Never carry a passenger. Carrying a passenger on this ATV greatly reduces your ability to balance and control this ATV. You could have an accident, resulting in severe injury or death to you and/or your passenger.**



### Apparel

Always wear the following to reduce risk of injury in an accident:

- Approved motorcycle helmet that fits properly
- Eye protection (goggles, helmet face shield, or protective eyewear)
- Over-the-ankle boots, gloves, long-sleeved shirt or jacket, and long pants

An approved helmet and other personal protective equipment can reduce the severity of injuries in an accident. **WARNING! Operating without an approved motorcycle helmet increases your chances of a severe head injury or death in the event of an accident.**

Wear eye protection when operating your ATV to reduce the risk of a serious accident or injury. Eye protection, such as a face shield or goggles, may reduce the risk of foreign material getting in your eyes and help prevent loss of vision. **WARNING! Operating without eye protection can result in an accident and increases your chances of a severe injury in the event of an accident.**

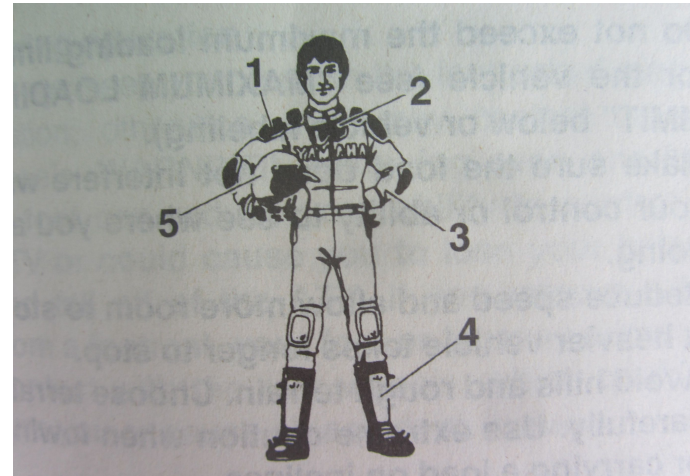

1. Protective clothing
2. Goggles
3. Gloves
4. Boots
5. Helmet

**Do not operate after or while consuming alcohol or drugs.**

The operator's performance capability is reduced by the influence of alcohol or drugs. Consuming alcohol or drugs could seriously affect your judgment, cause you to react more slowly, and affect your balance and perception. **WARNING! Never consume alcohol or drugs before or while driving this ATV. You increase your chance of an accident.**

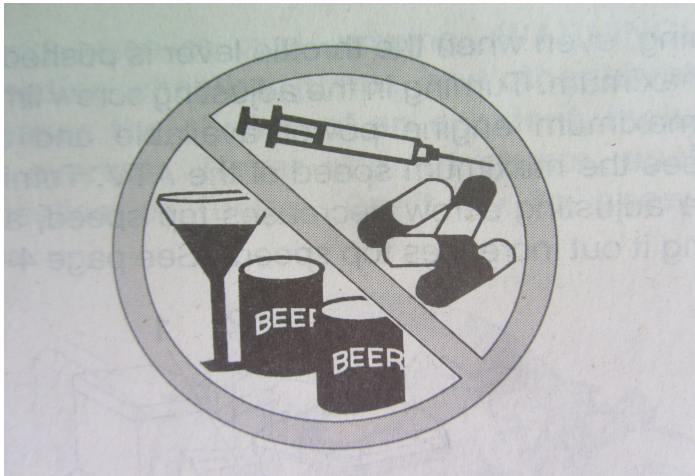

**Pre-operation checks**

Always inspect your ATV each time you use it to make sure the ATV is in safe operating condition. Perform the pre-operation checks listed on PRE-OPERATION CHECKS page.

Always follow the inspection and maintenance procedures and schedules described in the Owner's Manual. **WARNING! Failure to inspect the ATV before operating it and to maintain it properly increases the possibility of an accident**

**or equipment damage.**

**Speed limiter**

For riders less experienced with this model, the throttle lever housing is equipped with a speed limiter. The speed limiter keeps the throttle from fully opening, even when the throttle lever is pushed to the maximum. Turning in the adjusting screw limits the maximum engine power available and decreases the maximum speed of the ATV. Turning in the adjusting screw decreases top speed, and turning it out increases top speed.

**Loading and accessories**

**WARNING**

**Improper loading or towing can increase the risk of loss of control, and overturn, or other accident.**

To reduce the risk of an accident:

- Do not exceed the maximum loading limits for the vehicle (see "MAXIMUM LOADING LIMIT" below or vehicle labeling).
- Make sure the load does not interfere with your control or ability to see where you are going.
- Reduce speed and allow more room to stop a heavier vehicle takes longer to stop.
- Avoid hills and rough terrain. Choose terrain carefully. Use extreme caution when towing or carrying a load on inclines.
- Turn gradually and go slowly.

As originally equipped, this ATV is not designed to carry cargo or tow a trailer. If you choose to add accessories to carry cargo, you must use common sense and good judgment.

Use extra caution when riding the ATV with additional loads, such as accessories or cargo.

The ATV's handling may be adversely affected.

Reduce your speed when adding additional loads.

### **During operation**

Always keep your feet on the footrest during operation; otherwise, they may contact the rear wheels.

**WARNING! Removing even one hand or foot can reduce your ability to control the ATV or could cause you to lose your balance and fall off of the ATV. If you remove a foot from a footrest, your foot or leg may come into contact with the rear wheels, which could injure you or cause an accident.**

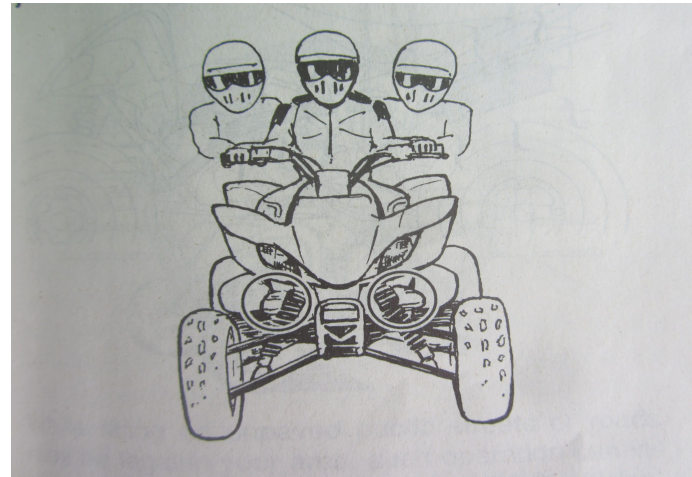

Avoid wheelies and jumping. **WARNING!** Attempting wheelies, jumps, and other stunts increase the chance of an accident, including an overturn. Never attempt stunts, such as wheelies or jumps. Don't try to show off.

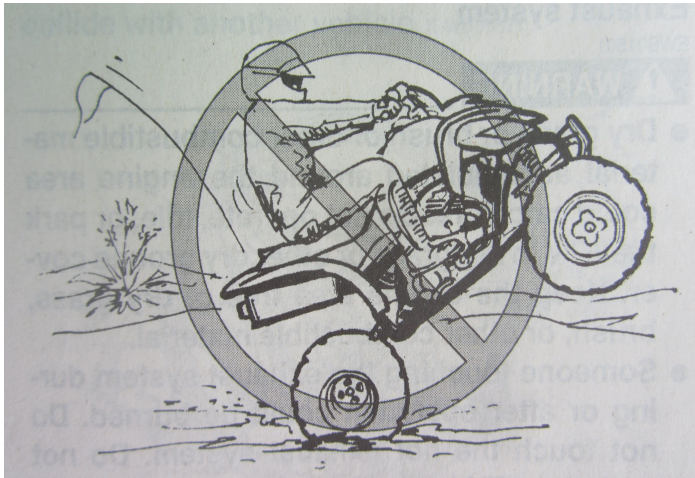

### **Modifications and accessories**

Never modify this ATV through improper installation or use of accessories or other modification. All parts and accessories added to this ATV should be original or equivalent components designed for use on this ATV and should be installed and used according to instructions. If you have questions consult a dealer.

**WARNING! Operating this ATV with improper modification may cause changes in handling which in some situations could lead to an accident.**

### **Exhaust system**

#### **WARNING**

- Dry grass or brush or other combustible material accumulated around the engine area could catch fire. Do not operate, idle, or park the ATV in dry grass or other dry ground cover. Keep the engine area free of dry grass, brush, or other combustible material.
- Someone touching the exhaust system during or after operation could be burned. Do not touch the hot exhaust system. Do not park the ATV in a place where others might be likely to touch it.

The muffler and other engine parts become extremely hot during operation and remain hot after the engine has stopped. To reduce the risk of fire during operation or after leaving the ATV, do not let brush, grass and other materials collect under the vehicle, near the muffler or exhaust pipe, or next to other hot parts. Check under the vehicle after operating in areas where combustible materials may have collected. Do not idle or park the vehicle in long dry grass or other dry ground cover.

To prevent burns, avoid touching the exhaust system.  
Park the ATV in a place where pedestrians or children are not likely to touch it.

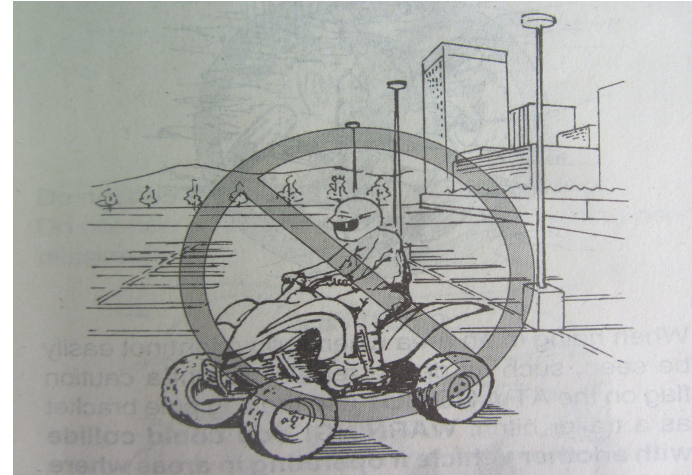
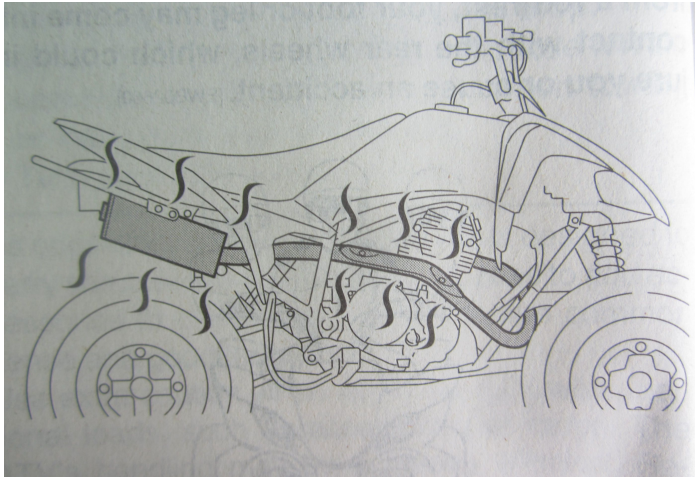

While riding on unpaved public streets or roads may be legal in your area, such operation can increase the risk of collision with other vehicles.

Watch carefully for other vehicles. Make sure you know your country's laws and regulations before you ride on unpaved public streets or roads. Do not ride on any paved public street, road or motorway.

**WARNING! Never operate this ATV on any paved street, paved road motorway. You can collide with another vehicle.**

### **BE CAREFUL WHERE YOU RIDE**

This ATV is designed for use on paved surfaces only.

**WARNING! Paved surfaces may seriously affect handling and control of the ATV, and may cause the ATV to go out of control. Always avoid paved surfaces, including sidewalks, driveways, parking lots and streets.**



Know the terrain where you ride. Ride cautiously in unfamiliar areas. Stay alert for holes, rocks, or roots in the terrain, and other hidden hazards which may cause the ATV to upset. **WARNING! The ATV could go out of control if you do not have enough time to react to hidden rocks, bumps, or holes. Go slowly and be extra careful when operating on unfamiliar terrain. Always be alert to changing terrain conditions when operating the ATV.**



Do not operate on rough, slippery, or loose terrain until you have learned and practiced the skills necessary to control the ATV on such terrain. Always be especially cautious on these kinds of terrain. **WARNING! Failure to use extra care when operating on excessively rough, slippery, or loose terrain could cause loss of traction or ATV control, which could result in an accident, including an overturn.**



When riding in an area where you might not easily be seen, such as desert terrain, mount a caution flag on the ATV. DO NOT use the flag pole bracket as a trailer hitch. **WARNING! You could collide with another vehicle if operating in areas where you can not easily be seen. Mount a caution flag on the ATV to make you more visible. Watch carefully for other vehicles.**

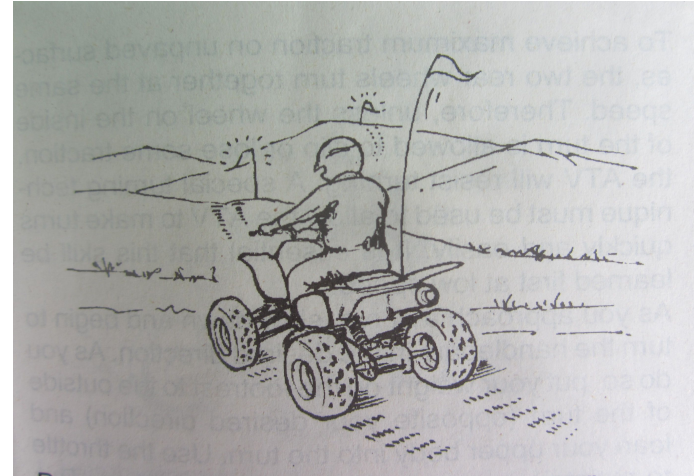

Do not ride in areas posted “no trespassing”.  
Do not ride on private property without getting permission.

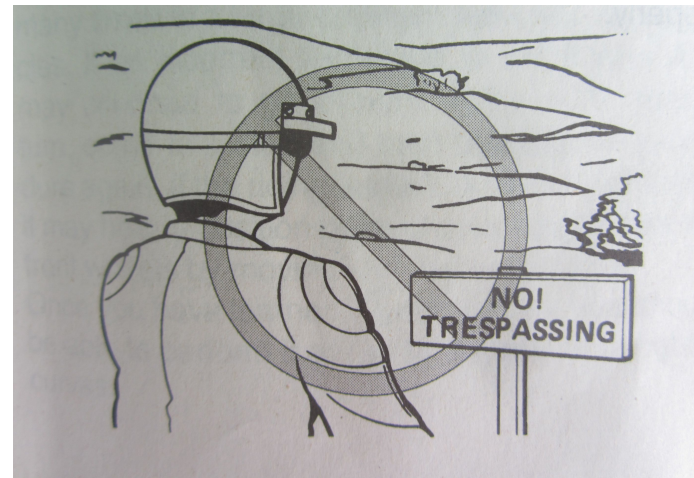

Select a large, flat, unpaved area to become familiar with your ATV. Make sure that this area is free of obstacles and other riders. You should practice control of the throttle, brakes, shifting procedures, and turning techniques in this area before trying more difficult terrain.

Follow the instruction to start the engine. Once it has warmed up you are ready to begin riding your ATV. As you get on the ATV, be sure not to accidentally move the shift pedal. With the engine idling, pull the clutch lever to disengage the clutch and shift into 1st gear, and then release the parking brake. Open the throttle gradually, and at the same time, release the clutch lever slowly. Once the ATV has attained adequate speed, release the throttle lever and at the same time, quickly pull in the clutch lever and shift into 2nd gear. Open the throttle part way and gradually release the clutch. **WARNING! If the throttle is applied too abruptly or if the throttle is not released during shifting, or if the shift pedal is not released before applying the throttle, the front wheels may lift off the ground, resulting in a loss of directional control. NOTICE: Do not shift gears without releasing the throttle. Damage to the engine or drive train may Occur.** Use this same procedure as you move into the higher gears. Be sure to coordinate the use of the throttle and shift pedal properly.

Avoid higher speeds until you are thoroughly familiar with the operation of your ATV. When slowing down or stopping, release the throttle and apply the brakes smoothly and evenly. As you slow down, shift to a lower gear. Be sure that the engine has sufficiently slowed before engaging a lower gear. Improper use of the brakes or shifting can cause the tires to lose traction, reducing control and increasing the possibility of an accident.

## TURNING YOUR ATV

### WARNING

**Always follow proper procedures for turning as described in this Owner's Manual. Practice turning at slow speeds before attempting to turn at faster speeds. Do not turn at speeds too fast for your skills or the conditions. ATV could go out of control, causing a collision or overturn.**

To achieve maximum traction on unpaved surfaces, the two rear wheels turn together at the same speed. Therefore, unless the wheel on the inside of the turn is allowed to slip or lose some traction, the ATV will resist turning. A special turning technique must be used to allow the ATV to make turns quickly and easily. It is essential that this skill be learned first at low speed.

As you approach a curve, slow and begin to turn the handlebars in the desired direction. As you do so, put your weight on the footrest to the outside of the turn (opposite your desired direction) and lean your upper body into the turn. Use the throttle to maximum an even speed through the turn. This maneuver will let the wheel on the inside of the turn slip slightly, allowing the ATV to make the turn properly.

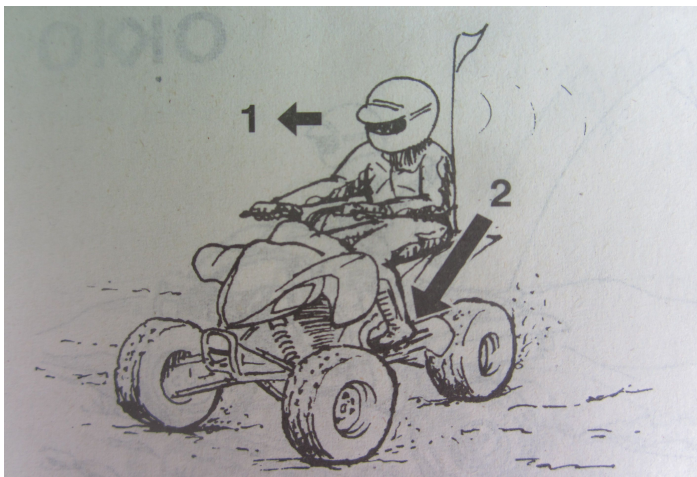

1. Lean towards inside of turn
2. Support your weight on the outer footrest

This procedure should be practiced at slow speed many times in a large unpaved area with no obstacles. If an incorrect technique is used, your ATV may continue to go straight. If the ATV doesn't turn, come to a stop and then practice the procedure again. If the riding surface is slippery or loose, it may help to position more of your weight over the front wheels by moving forward on the seat.

Once you have learned this technique, you should be able to perform it at higher speeds or in tighter curves. Improper riding procedures such as abrupt throttle changes, excessive braking, incorrect body movements, or too much speed for the sharpness of the turn may cause the ATV to tip. If the ATV begins to tip over to the outside while negotiating a turn, lean more to the inside. It may also be necessary to

gradually let off on the throttle and steer to the outside of the turn to avoid tipping over.

Remember: Avoid higher speeds until you are thoroughly familiar with the operation of your ATV.

## CLIMBING UPHILL

### WARNING

Climbing hills improperly can cause overturns or loss of control. Use proper riding techniques described in this owner's Manual.

- Never operate the ATV on hills too steep for the ATV or for your abilities. The ATV can overturn more easily on extremely steep hills than on level surfaces or small hills.
- Always check the terrain carefully before you start up any hill. Never climb hills with excessively slippery or loose surfaces.
- Shift your weight forward.
- Never open the throttle suddenly or make sudden gear changes. The ATV could flip over backwards.
- Never go over the top of any hill at high speed. An obstacle, a sharp drop, or another vehicle or person could be on the other side of the hill.
- Never attempt to turn the ATV around on any hill until you have mastered the turning techniques as described in the Owner's Manual on level ground. Be very careful when turning on any hill.
- Avoid crossing the side of a steep hill possible. When crossing the side of a hill, shift your weight to the uphill side of the ATV.



Do not attempt to climb hills until you have mastered basic maneuvers on flat ground. Always check the terrain carefully before attempting any hill. In all cases avoid inclines with slippery or loose surfaces, or obstacles that might cause you to lose control.

It is important when climbing a hill to make sure that you weight is transferred forward on the ATV. This can be accomplished by leaning forward and, on steeper inclines, standing on the footrests and leaning forward over the handlebars. Whenever possible, ride straight up hill. Slow down when you reach the crest of the hill if you cannot see clearly what is on the other side—there could be another person, an obstacle, or a sharp drop-off. Use common sense and remember that some hills are too steep for you to climb or descend.

If you are climbing a hill and you find that you have not properly judged your ability to make it to the top, you should turn the ATV around while you still have forward motion (provided you have the room to do so) and go down the hill. If your ATV has stalled or stopped and you believe you can continue up the hill, restart carefully to make sure you do not lift the front wheels which could cause you to lose control. If you are unable to continue up the hill, dismount the ATV on the up-hill side. Physically turn the ATV around and then descend the hill.

If you start to roll backwards, DO NOT apply the rear brake, and apply the front brake gradually. The ATV could easily tip over backwards. When fully stopped, apply the rear brake as well. Dismount the ATV immediately on the uphill side or to a side if pointed straight uphill. Turn the ATV around and remount, following the procedure described in the Owner's manual.

**WARNING! Stalling, rolling backwards or improperly dismounting while climbing a hill could result in ATV overturning. If you cannot control the ATV, dismount immediately on the uphill side.**

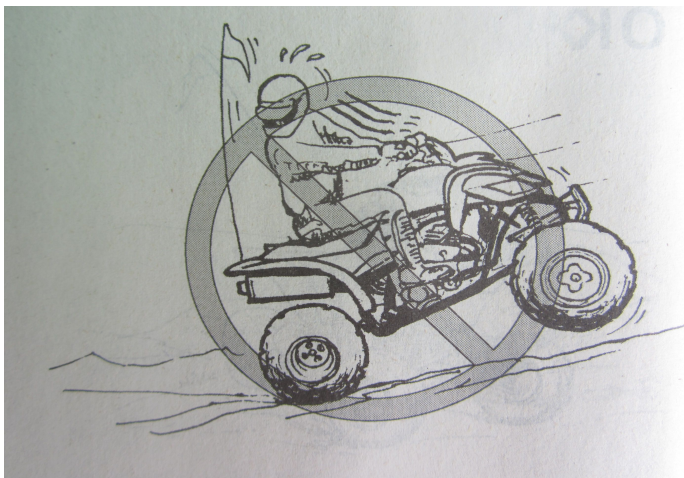

## **RIDING DOWNHILL**

### **WARNING**

**Going down a hill improperly could cause overturn or loss of control. Always follow proper procedures for going down hills as described in this Owner's Manual.**

- **Always check the terrain carefully before you start down any hill.**
- **Never operate the ATV on hills too steep for the ATV or for your abilities. The ATV can overturn more easily on extremely steep hills than on level surfaces or small hills.**
- **Shift your weight backward and to the top side of the hill.**
- **Never go down a hill at high speed.**

- **Avoid going down a hill at an angle that would cause the ATV to lean sharply to one side. Go straight down the hill where possible.**
- **Improper braking can cause the wheels on the uphill side to come off the ground or cause loss of traction. gradually apply only the rear brake when going downhill.**

When riding your ATV downhill, shift your weight as far to the rear and uphill side of the ATV as possible. Move back on the seat and sit with your arms straight. Choose a low gear which will allow the engine compression to do most of the braking for you.

Use caution while descending a hill with loose or slippery surfaces. Braking ability and traction may be adversely affected by these surfaces. Improper braking may also cause a loss of traction. Gradually apply only the rear brake.

Whenever possible, ride your ATV straight downhill. Avoid sharp angles which could allow the ATV to tip or roll over. Carefully choose your path and ride no faster than you will be able to react to obstacles which may appear.



Traversing a sloping surface on your ATV requires you to properly position your weight to maintain proper balance. Be sure that you have learned the basic riding skills on flat ground before attempting to cross a sloping surface. Avoid slopes with slippery surface or rough terrain that may upset your balance.

As you travel across a slope, lean your body in the uphill direction. It may be necessary to correct the steering when riding on loose surfaces by pointing the front wheels slightly uphill. When riding on slopes, be sure not to make sharp turns either up or down hill.

## CROSSING A SLOPE

### WARNING

Improperly crossing hills or turning on hills could cause loss of control or cause the ATV to overturn.

- Always follow proper procedures as described in the Owner's Manual.
- Avoid hills with excessively slippery or loose surfaces.
- Avoid crossing the side of a steep hill.
- Shift your weight to the uphill side of the ATV.
- Never attempt to turn the ATV around on any hill until you have mastered the turning technique as described in the Owner's Manual on level ground. Be very careful when turning on any hill.

If your ATV does begin to tip over, gradually steer in the downhill direction if there are no obstacles in your path. As you regain proper balance, gradually steer again in the direction you wish to travel.



## CROSSING THROUGH SHALLOW WATER

### WARNING

Operating this vehicle through deep or fast-flowing water can lead to loss of control or an overturn. To reduce your risk of drowning or other injuries, use care when crossing through water. Never operate this ATV in water deeper than the depth specified in your Owner's Manual, as tires may float, increasing the risk of an overturn.

The ATV can be used to cross slow moving, shallow water of up to a maximum of 35 cm ( 4 in) in depth. Before entering the water, choose your path carefully. Enter where there is no sharp drop off, and avoid rocks or other obstacles which may be slippery or upset the ATV. Drive slowly and carefully.

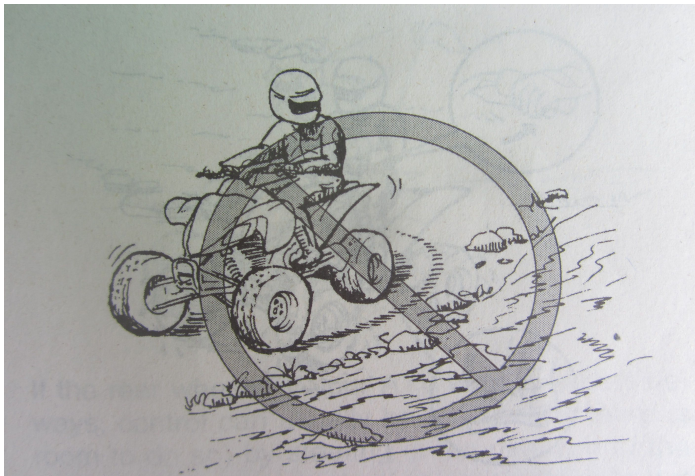

Test your brakes after leaving the water. If necessary,

apply them several times to let friction dry out the linings. Do not continue to ride your ATV without verifying that you have regained proper braking ability. **WARNING! Wet brakes may have reduced stopping ability, which could cause loss of control.**

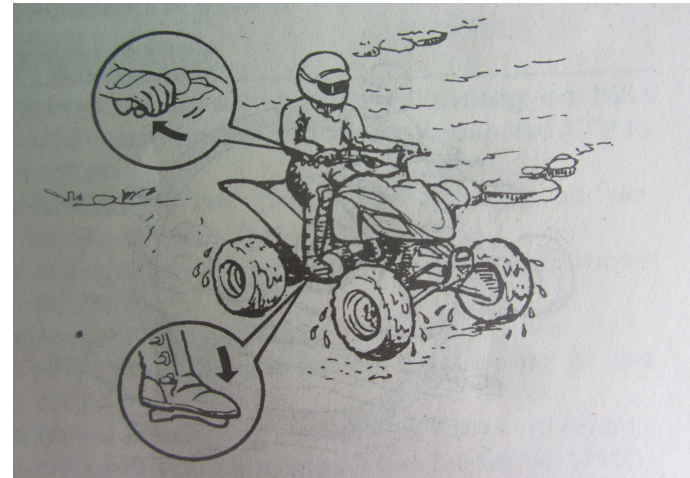

After riding your ATV in water, be sure to drain the trapped Water by removing the check hose at the bottom of the air Filter case. **Notice:** Undrained water can cause damage or Improper operation. Wash the ATV in fresh water if it has been operated in salt Water or muddy conditions.

## RIDING OVER ROUGH TERRAIN

### WARNING

Riding improperly over obstacles could cause loss of control or a collision. Before operating in a new area, check for obstacles. Never attempt to ride over large obstacles, such as large rocks or fallen trees. When you go over obstacles, always follow proper procedures as described in the Owner's Manual.

Riding over rough terrain should be done with caution. Look out for obstacles which could cause damage to the ATV or could lead to an upset or accident. Be sure to keep your feet firmly mounted on the footrests at all times. Avoid jumping the ATV as loss of control and damage to the ATV may result.

## SLIDING AND SKIDDING

### WARNING

Skidding or sliding improperly may cause you to lose control of this ATV. You may also regain traction unexpectedly, which may cause the ATV to overturn.

- Learn to safely control skidding or sliding by practicing at low speeds and on levels, smooth terrain.
- On extremely slippery surfaces, such as ice, go slowly and be very cautious in order to re-

duce the chance of skidding or sliding out of control.

Care should be used when riding on loose or slippery surfaces since the ATV may slide. If unexpected and uncorrected, sliding could lead to an accident. To reduce the tendency for the front wheels to slide in loose or slippery conditions, positioning your weight over the front wheels will sometimes help.



If the rear wheels of your ATV start to slide sideways, control can usually be regained (if there is room to do so) by steering in the direction of the slide. Applying the brakes or accelerating is not recommended until you have corrected the slide.



With practice, over a period of time, skill at controlled sliding can be developed. The terrain should be chosen carefully before attempting such maneuvers, since both stability and control are reduced. Bear in mind that sliding maneuvers should always be avoided on extremely slippery surfaces such as ice, since all control may be lost.

#### **WHAT TO DO IF...**

This section is designed to be a reference guide only. Be sure to read each section on riding techniques completely.

#### **WHAT TO DO...**

- If your ATV doesn't turn when you want it to: Bring the ATV to a stop and practice the turning maneuvers again. Be sure you are putting your weight on the footrest to the outside of the turn.

position your weight over the front wheels for better control.

- If your ATV begins to tip while turning: Lean more into the turn to regain balance. If necessary, gradually let off the throttle and/or steer to the outside of the turn.
- If your ATV starts to slide sideways: Steer in the direction of the slide if you have the room. Applying the brakes or accelerating is not recommended until you have corrected the slide.
- If your ATV can't make it up a hill you are trying to climb: Turn the ATV around if you still have forward speed. If not, stop, dismount on the uphill side of the ATV and physically turn the ATV around. If the ATV starts to slip backwards, **DO NOT USE THE REAR BRAKE** -- the ATV may tip over on top of you. Dismount the ATV on the hill side.
- If your ATV is traversing a sloping surface: Be sure to ride with your weight positioned towards the uphill side of the ATV to maintain proper balance. If the ATV starts to tip, steer down the hill (if there are no obstacles in your way) to regain balance. If you discover that the ATV is going to tip over, dismount on the uphill side.
- If your ATV encounters shallow water: Ride slowly and carefully through slow moving water, watching for obstacles. Be sure to let water drain from the ATV and **CHECK YOUR BRAKES FOR PROPER OPERATION** when you come out of the water. Do not continue to ride your ATV until you have regained adequate braking ability.

## **PERIODIC MAINTENANCE AND ADJUSTMENT**

Periodic inspection, adjustment, and lubrication will keep your vehicle in the safest and most efficient condition possible. Safety is an obligation of the vehicle owner/operator. The most important points of vehicle inspection, adjustment, and lubrication are explained on the following pages.

### **WARNING**

**Failure to properly maintain the vehicle or performing maintenance activities incorrectly may increase your risk of injury or death during service or while using the vehicle. If you are not familiar with vehicle service, have a dealer perform the service.**

### **WARNING**

**Turn off engine when performing maintenance unless otherwise specified.**

- **A running engine has moving parts that can catch on body parts or clothing and electrical parts that can cause shocks or fires.**
- **Running the engine while servicing can lead to eye injury, burns, fire, or carbon monoxide poisoning - possibly leading to death.**

### **WARNING**

**Brake discs, calipers, drums, and linings can become very hot during use. To avoid possible burns, let brake components cool before touching them.**

The intervals given in the periodic maintenance charts should be considered as a general guide under normal riding conditions. However, **DEPENDING ON THE WEATHER, TERRAIN, GEOGRAPHICAL LOCATION, AND INDIVIDUAL USE, THE MAINTENANCE INTERVALS MAY NEED TO BE SHORTENED.**

## Owner's manual and tool kit

Be sure to put this owner's manual in the manual box and the owner's tool kit under the seat.

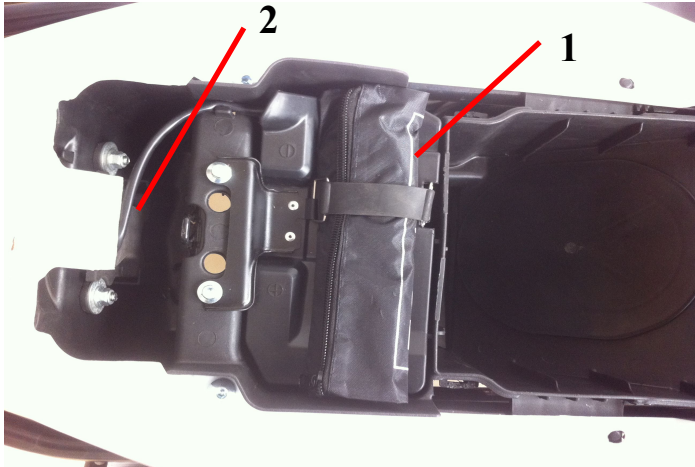

1. Owner's tool kit
2. Owner's manual box

The service information included in this manual and the tool provided in the owner's tool kit are intended to assist you in the performance of preventive maintenance and minor repairs. However, additional tools such as a torque wrench may be necessary to perform certain maintenance Work correctly.

## TIP

If you do not have the tools or experience required for a particular job, have a dealer perform it for you.

## Periodic maintenance chart for the emission control system

### TIP

- For ATVs not equipped with an odometer or an hour meter, follow the month maintenance intervals.
- For ATVs equipped with an odometer or an hour meter, follow the km (mi) or hours maintenance intervals. However, keep in mind that if the ATV isn't used for a long period of time, the month maintenance intervals should be followed.
- Items marked with an asterisk should be performed by a dealer as they require special tools, data and technical skills.

NO.	ITEM	CHECK OR MAINTENANCE JOB	Whichever comes first  ⇒	INITIAL			EVERY		
				month	1	3	6	6	12
				Km (mi)	320 (200)	1300 (800)	2500 (1600)	2500 (1600)	5000 (3200)
hours	20	80	160	160	320				
1	*	<b>Fuel line</b>	<ul style="list-style-type: none"> <li>• Check fuel hoses for cracks or other damage, and replace if necessary</li> </ul>			✓	✓	✓	
2	*	<b>Spark plug</b>	<ul style="list-style-type: none"> <li>• Check condition and clean, regap, or replace if necessary.</li> </ul>	✓	✓	✓	✓	✓	
3	*	<b>Valves</b>	<ul style="list-style-type: none"> <li>• Check valve clearance and adjust if necessary.</li> </ul>	✓		✓	✓	✓	
4	*	<b>Carburetor</b>	<ul style="list-style-type: none"> <li>• Check starter (choke) operation and correct if necessary.</li> <li>• Check engine idling speed and adjust if necessary.</li> </ul>		✓	✓	✓	✓	
5	*	<b>Crankcase breather system</b>	<ul style="list-style-type: none"> <li>• Check breather hose for cracks or other damage, and replace if necessary.</li> </ul>			✓	✓	✓	
6	*	<b>Exhaust system</b>	<ul style="list-style-type: none"> <li>• Check for leakage and replace gasket(s) if necessary.</li> <li>• Check for looseness and tighten all screw clamps and joints if necessary.</li> </ul>			✓	✓	✓	

## General maintenance and lubrication chart

### TIP

- For ATVs not equipped with an odometer or an hour meter, follow the month maintenance intervals.
- For ATVs equipped with an odometer or an hour meter, Follow the km (mi) or hours maintenance intervals.  
However, keep in mind that if the ATV isn't used for a long period of time, the month maintenance intervals should be followed.
- Items marked with an asterisk should be performed by a dealer as they require special tools, data and technical skills.

NO.	ITEM	CHECK OR MAINTENANCE JOB	Whichever comes first  ⇒	INITIAL			EVERY		
				month	1	3	6	6	12
				Km (mi)	320 (200)	1300 (800)	2500 (1600)	2500 (1600)	5000 (3200)
				hours	20	80	160	160	320
1	*	<b>Air filter element</b>	<ul style="list-style-type: none"> <li>Clean and replace if necessary</li> </ul>	Every 20-40 hours (more often in wet or dusty areas)					
2	*	<b>Clutch</b>	<ul style="list-style-type: none"> <li>Check operation and adjust if necessary.</li> </ul>	✓		✓	✓	✓	
3	*	<b>Front brake</b>	<ul style="list-style-type: none"> <li>Check operation and correct if necessary.</li> <li>Check fluid level and ATV for fluid leakage, and correct if necessary.</li> </ul>	✓	✓	✓	✓	✓	
			<ul style="list-style-type: none"> <li>Replace brake pads</li> </ul>	Whenever worn to the limit					
4	*	<b>Rear brake</b>	<ul style="list-style-type: none"> <li>Check operation and correct if necessary.</li> <li>Check fluid level and ATV for fluid leakage, and correct if necessary.</li> </ul>	✓	✓	✓	✓	✓	
			<ul style="list-style-type: none"> <li>Replace brake pads.</li> </ul>	Whenever worn to the limit					

NO	ITEM	CHECK OR MAINTENANCE JOB	Whichever comes first ⇒	INITIAL			EVERY		
				month	1	3	6	6	12
				Km (mi)	320 (200)	1300 (800)	2500 (1600)	2500 (1600)	5000 (3200)
				hours	20	80	160	160	320
5	*	Brake hoses	<ul style="list-style-type: none"> <li>• Check for cracks or other damage, and replace if necessary.</li> <li>• Replace</li> </ul>		✓	✓	✓	✓	
				Every 4 years					
6	*	Wheels	<ul style="list-style-type: none"> <li>• Check runout and for damage, and replace if necessary.</li> </ul>	✓		✓	✓	✓	
7	*	Tires	<ul style="list-style-type: none"> <li>• Check tread depth and for damage, and replace if necessary.</li> <li>• Check air pressure and balance, and correct if necessary.</li> </ul>	✓		✓	✓	✓	
8	*	Wheel hub bearing	<ul style="list-style-type: none"> <li>• Check for looseness or damage, and replace if necessary.</li> </ul>	✓		✓	✓	✓	
9	*	Swing arm pivots	<ul style="list-style-type: none"> <li>• Check operation and for excessive play, and replace bearing if necessary.</li> <li>• Lubricate with lithium-soap-based grease.</li> </ul>			✓	✓	✓	
10	*	Upper and lower arm pivots	<ul style="list-style-type: none"> <li>• Lubricate with lithium-soap-based grease.</li> </ul>			✓	✓	✓	
11	*	Drive chain	<ul style="list-style-type: none"> <li>• Check chain slack and adjust if necessary.</li> <li>• Check rear wheel alignment and correct if necessary.</li> <li>• Clean and lubricate.</li> </ul>	✓	✓	✓	✓	✓	
12	*	Drive chain roller	<ul style="list-style-type: none"> <li>• Check for wear and replace if necessary.</li> </ul>			✓	✓	✓	

NO.	ITEM	CHECK OR MAINTENANCE JOB	Whichever comes first  ⇒	INITIAL			EVERY		
				month	1	3	6	6	12
				Km (mi)	320 (200)	1300 (800)	2500 (1600)	2500 (1600)	5000 (3200)
				hours	20	80	160	160	320
13	*	Chassis fasteners	<ul style="list-style-type: none"> <li>Make sure that all nuts, bolts, and screws are properly tightened.</li> </ul>	✓	✓	✓	✓	✓	
14	*	Shock absorber assemblies	<ul style="list-style-type: none"> <li>Check operation and correct if necessary</li> <li>Check for oil leakage and replace if necessary.</li> </ul>			✓	✓	✓	
15	*	Steering shaft	<ul style="list-style-type: none"> <li>Lubricate with lithium-soap-based grease.</li> </ul>			✓	✓	✓	
16	*	Steering system	<ul style="list-style-type: none"> <li>Check operation and repair or replace if damaged.</li> <li>Check toe-in and adjust if necessary.</li> </ul>	✓	✓	✓	✓	✓	
17	*	Engine oil	<ul style="list-style-type: none"> <li>Change</li> <li>Check ATV for oil leakage, and correct if necessary.</li> </ul>	✓		✓	✓	✓	
18	*	Engine oil filter element	<ul style="list-style-type: none"> <li>Clean and replace if necessary</li> <li>Replace.</li> </ul>	✓		✓		✓	
19	*	Moving parts and cables	<ul style="list-style-type: none"> <li>Lubricate.</li> </ul>		✓	✓	✓	✓	
20	*	Throttle lever	<ul style="list-style-type: none"> <li>Check operation.</li> <li>Check throttle lever free play, and adjust if necessary.</li> <li>Lubricate cable and lever housing.</li> </ul>	✓	✓	✓	✓	✓	
21	*	Front and rear brake switches	<ul style="list-style-type: none"> <li>Check operation and correct if necessary.</li> </ul>	✓	✓	✓	✓	✓	
22	*	Lights and switches	<ul style="list-style-type: none"> <li>Check operation and correct if necessary.</li> <li>Adjust headlight beams</li> </ul>	✓	✓	✓	✓	✓	

## TIP

- Some maintenance items need more frequent service if you are riding in unusually wet, dusty, sandy or muddy areas, or at full-throttle.
- Hydraulic brake service  
Regularly check and, if necessary, correct the brake fluid

## Checking the spark plug

The spark plug is an important engine component, which is easy to check. Since heat and deposits will cause any spark plug to slowly erode, the spark plug should be removed and checked in accordance with the periodic maintenance and lubrication chart. In addition, the condition of the spark plug can reveal the condition of the engine.

### To remove the spark plug

1. Remove the spark plug cap.

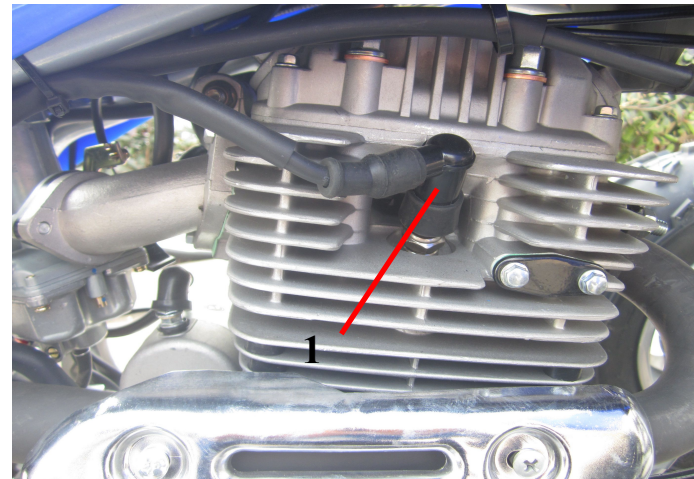

1. Spark plug cap

2. Remove the spark as shown, with the spark plug wrench included in the owner's tool Kit.

To check the spark plug

1. Check that the porcelain insulator around the center electrode of the spark plug is a medium-to-light tan (the ideal color when the ATV is ridden normally).

**TIP**

If the spark plug shows a distinctly different color, the engine could be operating improperly. Do not attempt to diagnose such problems yourself. Instead, have a dealer check the ATV.

2. Check the spark plug gap for electrode erosion and excessive carbon or other deposits, and replace it if necessary.
3. Measure the spark plug gap with a wire thickness gauge and, if necessary, adjust the gap to specification.

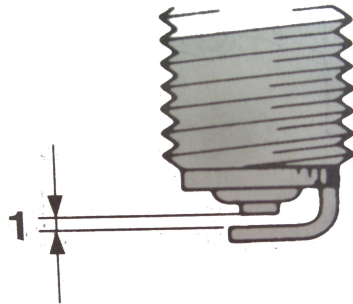

1. Spark plug gap

Spark plug gap:  
0.6-0.7mm (0.024-0.028 in)

**To install the spark plug**

1. Clean the surface of the spark plug gasket and its mating surface, and then wipe off any grime from the the spark plug threads.
2. Install the spark plug with the spark plug wrench, and then tighten it to the specified torque.

Tightening torque:  
Spark plug:  
18Nm(1.8m·kgf, 13ft·lbf)

**TIP**

If a torque wrench is not available when installing the spark plug, a good estimate of the correct torque is 1/4-1/2 turn past finger tight. However, the spark should be tightened to the specified torque as soon as possible.

3. Install the spark plug cap.

## Engine oil and oil filter element

The engine oil level should be checked before each ride, in addition, the oil must be changed and the oil filter element must be replaced at the intervals specified in the periodic maintenance and lubrication chart.

### To check the engine oil level

1. Place the ATV on a level surface.
2. Check the engine oil level on a cold engine.

### TIP

If the engine was started before checking the oil level, be sure to warm up the engine sufficiently, and then wait at least ten minutes until the oil settles for an accurate reading.

3. Remove the engine oil filter cap, and then wipe the engine oil Dipstick off with a clean rag.
4. Insert the dipstick into the filter hole (without screwing it in), and then remove it again to check the oil level.

### TIP

The engine oil should be between the minimum and maximum level marks.

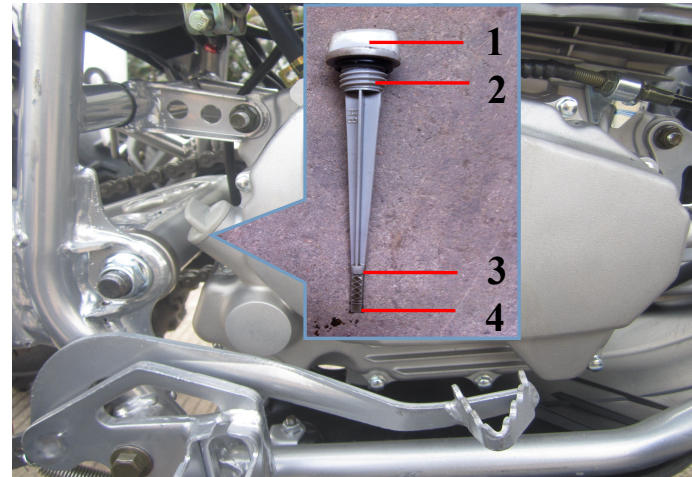

1. Engine oil filler cap
2. Engine oil dipstick
3. Maximum level mark
4. Minimum level mark

5. If the engine oil is at or below the minimum level mark, add sufficient oil of the recommended type to raise it to the correct level.

**NOTICE: Be sure the engine oil is at the correct level, otherwise engine damage may result.**

6. Insert the dipstick into the oil filter hole, and then tighten the engine filter cap.

**To change the engine oil (with or without oil filter element replacement)**

1. Place the ATV on a level surface.
2. Start the engine, warm it up for several minutes, and then turn it off.
3. Place an oil pan under the engine to collect the used oil.
4. Remove the engine oil filler cap, and then remove the engine oil drain bolt to drain the oil from the crankcase.

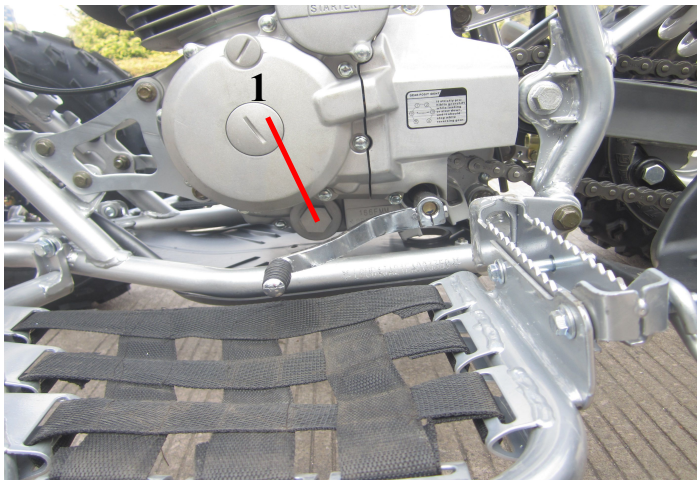

1. Engine oil drain bolt

5. Install the engine oil drain bolt , and then tighten the bolt to the specified torque.

Tightening torque:

Engine oil drain bolt:

20 Nm (2.0 m·kgf, 14 ft·lbf)

6. Refill with the specified amount of the recommended engine oil

**TIP**

Be sure to wipe off spilled oil on any parts after the engine and exhaust system have cooled down.

**NOTICE**

- In order to prevent clutch slippage (since the engine oil also lubricates the clutch), do not mix any chemical additives. Do not use oils with a diesel specification of “CD” or oils of a higher quality than specified. In addition, do not use oils labeled “ENERGY CONSERVING II” or higher.
- Make sure that no foreign material enters the crankcase.

7. Start the engine, and then let it idle for several minutes while checking it for oil leakage. If oil is leaking, immediately turn the engine off and check for the cause.
8. Turn the engine off, wait at least ten minutes, and then check the oil level and correct it if necessary.

## Cleaning the air filter element

The air filter element should be cleaned at the intervals specified in the periodic maintenance and lubrication chart. Clean or, if necessary, replace the air filter element more frequently if you are riding in unusually wet or dusty areas.

### TIP

There is a check hose at the bottom of the air filter case. If dust or water collects in this hose, empty the hose and clean the air filter element and air filter case.

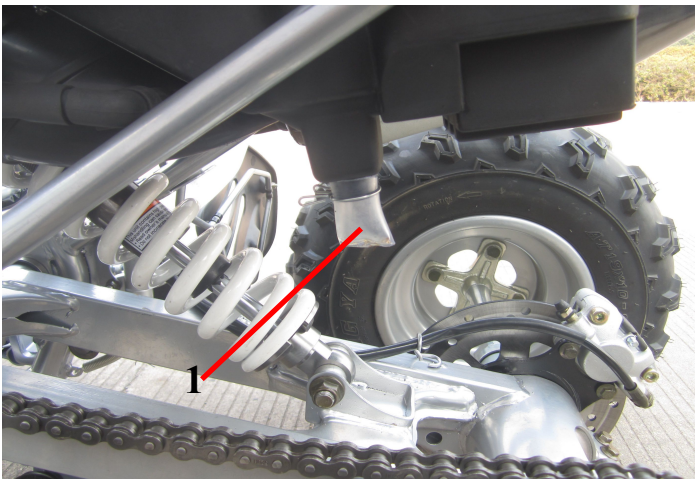

1. Air filter case check hose

1. Place the ATV on a level surface.
2. Remove the seat.
3. Remove the air filter case cover by unhooking the holders.

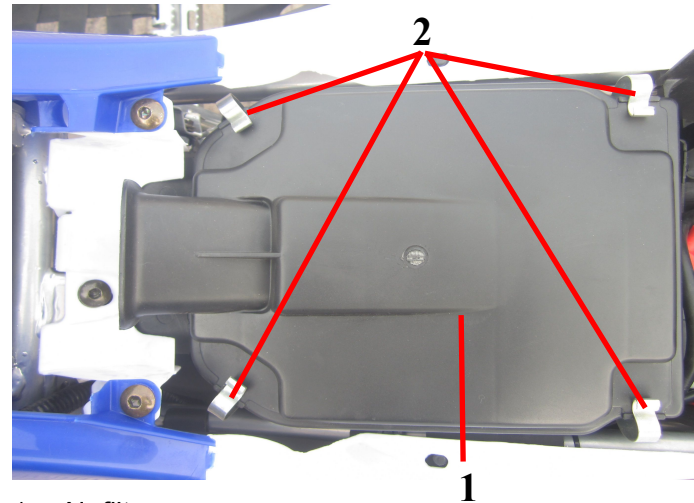

1. Air filter case cover

2. Air filter case cover holder

4. Loosen the wing bolt.

5. Remove the air filter element together with the wing bolt and washer.

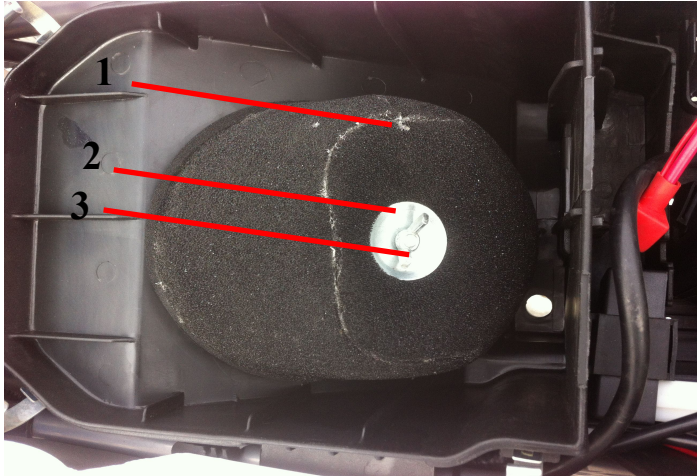

1. Air filter element
2. Washer
3. Wing bolt

6. Remove the wing bolt and washer from the air filter element.
7. Remove the sponge material from the air filter element frame.

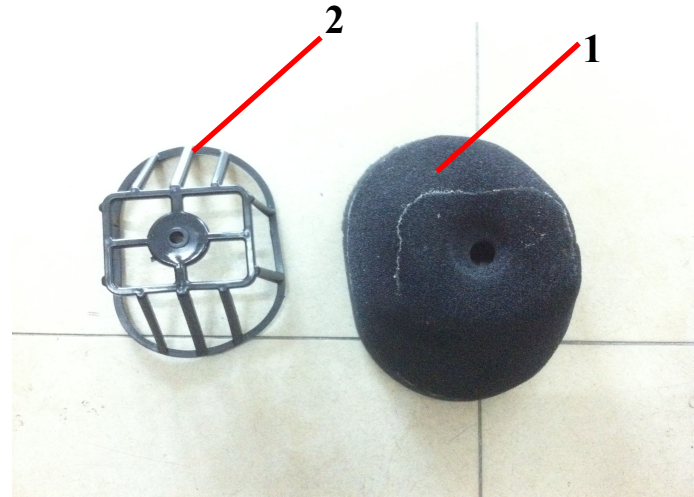

1. Sponge material
2. Air filter element frame

8. Wash the sponge material gently but thoroughly in solvent. **WARNING! Always use parts cleaning solvent to clean the sponge material. Never use low-flash-point solvents or gasoline to clean the sponge material because the engine could catch fire or explode.**
9. Squeeze the excess solvent out of the sponge material and let it dry. **NOTICE: Do not twist the sponge material when squeezing it.**
10. Check the sponge material and replace it if damaged.
11. Apply foam air filter oil or other quality foam air filter oil to the sponge material.

### TIP

The sponge material should be wet but not dripping.

12. Pull the sponge material over the air filter element frame.
13. Apply all-purpose grease to the air filter element seat.



1. Air filter element seat

14. Install the washer onto the air filter element frame, and then insert the wing bolt into the hole in the air filter element frame. **NOTICE: Be sure to install the washer with its curved side facing outward.**
15. Insert the air filter element into the air filter case, and then tighten the wing bolt. **NOTICE: Make sure that the air filter**

**element is properly seated in the air filter case. Never operate the engine with the air filter element removed. This will allow unfiltered air to enter the engine, causing rapid engine wear and possible engine damage. Additionally, operation without the air filter element will affect carburetor jetting with subsequent poor performance and possible engine overheating.**

16. Install the air filter case cover by hooking the holders onto the air filter case.
17. Install the seat.

### TIP

The air filter element should be cleaned every 20-40 hours. It should be cleaned and lubricated more often if the ATV is operated in extremely dusty areas. Each time the air filter element maintenance is performed, check the air inlet of the air filter case for obstructions. Check the air filter case rubber joint to the carburetor fittings and the rubber joint manifold fittings for an air-tight seal. Tighten all fittings securely to avoid the possibility of unfiltered air entering the engine.

### Adjusting the carburetor

The carburetor should be checked and, if necessary, adjusted at the intervals specified in the periodic maintenance and lubrication chart. The carburetor is an important part of the engine and requires very sophisticated adjustment. Therefore, most carburetor adjustments should be left to a dealer, who has the necessary professional knowledge and experience. The adjustment described in the following section, however, may be performed by the owner as part of routine maintenance.

### NOTICE

The carburetor has been set and extensively tested at the factory. Changing these settings without sufficient technical knowledge may result in poor performance of or damage to the engine.

### Adjusting the engine idling speed

The engine idling speed must be checked and, if necessary, adjusted as follows at the intervals specified in the periodic maintenance and lubrication chart.

### TIP

A diagnostic tachometer is needed to make this adjustment.

1. Start the engine and warm it up.

### TIP

The engine is warm when it quickly responds to the throttle.

2. Attach the tachometer to the spark plug lead.
3. Check the engine idling speed and, if necessary, adjust it to specification by turning the throttle stop screw at the carburetor. To increase the engine idling speed, turn the throttle stop screw clockwise, and to decrease it, turn the screw counter-clockwise.

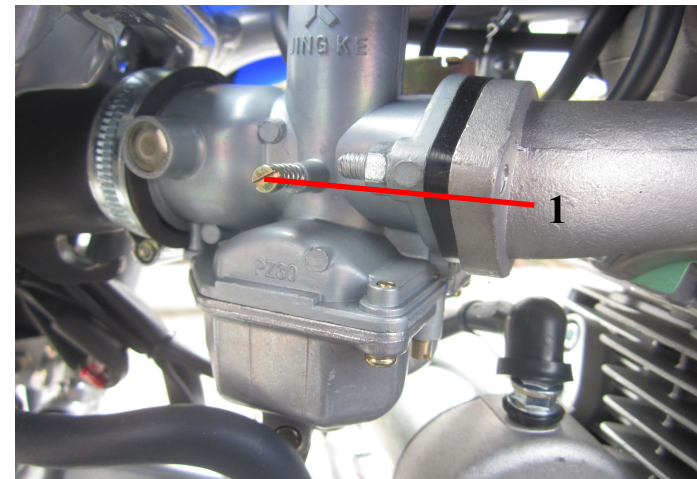

1. Throttle stop screw

### TIP

If the specified idling speed cannot be obtained as described above, have a dealer make the adjustment.

### **Adjusting the throttle level free play**

The throttle level free play should be checked and, if necessary, adjusted at the intervals specified in the periodic maintenance and lubrication chart.

The throttle lever free play should measure 2.0-4.0 mm (0.08-0.16 in) as shown. Periodically check the throttle lever free play and, if necessary, adjust it as follows.

#### **TIP**

The engine idling speed must be checked, and adjusted if necessary, before adjusting the throttle level free play.

To increase the throttle lever free play, turn the throttle lever free play adjusting bolt counterclockwise. To decrease the throttle lever free play, turn the adjusting bolt clockwise.



1. Throttle lever free play adjusting bolt

### **Valve clearance**

The valve clearance changes with use, resulting in improper air-fuel mixture and/or engine noise. To prevent this from occurring, the valve clearance must be adjusted by a dealer at the intervals specified in the periodic maintenance and lubrication chart.

### **Brakes**

Replacement of the brake components requires professional knowledge. Brake service should be performed by a dealer.

#### **WARNING**

**Operating with improperly serviced or adjusted brakes could lead to a loss in braking ability and an accident.**

### **Checking the front and rear brake pads**

The front and rear brake pads must be checked for wear at the intervals specified in the periodic maintenance and lubrication chart.

#### **Front brake pads**

Each brake pad is provided with a wear indicator groove, which allows you to check the brake pad wear without having to disassemble the brake. To check the brake pad wear, check the wear indicator groove. If a brake pad has worn to the point that the wear indicator groove has almost disappeared, have a dealer replace the brake pads as a set.

#### **TIP**

The wheels need to be removed to check the brake pads.

### Rear brake pads

Each brake pad is provided with two wear indicator grooves, which allow you to check the brake pad wear without having to disassemble the brake. To check the brake pad wear, check the wear indicator grooves. If a brake pad has worn to the point that a wear indicator groove almost appears, have a dealer replace the brake pads as a set.

### Checking the brake fluid level

Before riding, check that the brake fluid is above the minimum level mark. Check the brake fluid level with the top of the reservoir level. Replenish the brake fluid if necessary.

### Front brake



1. Minimum level mark

### WARNING

**Improper maintenance can result in loss of braking ability.**

### Observe these precautions:

**Insufficient brake fluid may allow air to enter the brake system, reducing braking performance.**

- **Clean the filler cap before removing. Use brake fluid from a sealed container.**
- **Use only the specified brake fluid; otherwise, the rubber seals may deteriorate, causing leakage.**
- **Refill with the same type of brake fluid. Adding a brake fluid other may result in a harmful chemical reaction.**
- **Be careful that water does not enter the brake fluid reservoir when refilling. Water will significantly lower the boiling point of the fluid and may result in vapor lock.**

### NOTICE

**Brake fluid may damage painted surfaces or plastic parts. Always clean up spilled fluid immediately.**

As the brake pads wear, it is normal for the brake fluid level to gradually go down. A low brake fluid level may indicate worn brake pads and/or brake system leakage; therefore, be sure to check the brake pads for wear and the brake system for leakage. If the brake fluid level goes down suddenly, have a dealer check the cause before further riding.

### Changing the brake fluid

Have a dealer change the brake fluid at the intervals specified in the TIP after the periodic maintenance and lubrication chart. In addition, have the oil seals of the master cylinders and calipers as well as the brake hoses replaced at the intervals listed below or whenever they are damaged or leaking.

### Checking the front brake level free play

The brake level free play must be checked at the intervals specified in the periodic maintenance and lubrication chart. The brake level should have no free play as shown. If there is free play, have a dealer check the brake system.



1. No brake level free play

### Checking the brake pedal height

The brake pedal height must be checked and, if necessary, adjusted at the intervals specified in the periodic maintenance and lubrication chart.

The top of the brake pedal should be positioned 40.0 mm (1.57 in) above the top of the frame as shown. If the brake pedal is not positioned as specified, have a dealer adjust it.

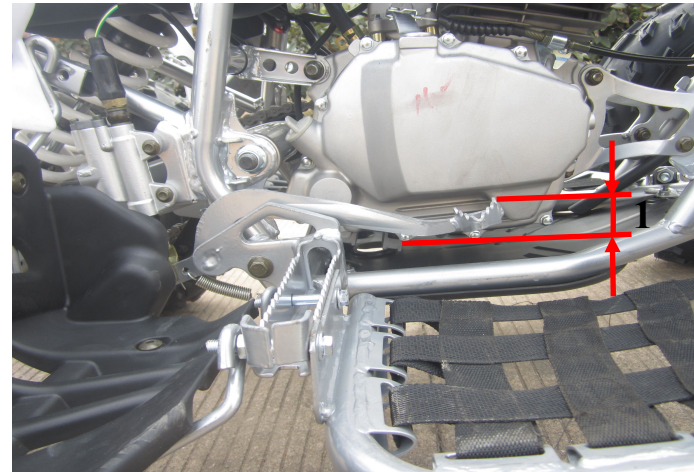

1. Brake pedal height

### Adjusting the clutch lever free play

The clutch lever free play must be checked and, if necessary, adjusted at the intervals specified in the periodic maintenance and lubrication chart.

The clutch lever free play should measure 5.0- 10.0 mm (0.20-0.39 in) as shown, if the free play is incorrect, adjust it as follows.



1. Locknut
2. Clutch lever free play adjusting bolt

1. Loosen the locknut to the clutch lever,
2. To increase the clutch lever free play, turn the adjusting bolt counterclockwise, and to decrease it, turn the bolt clockwise.
3. Tighten the locknut.

**TIP**

If the specified free play cannot be obtained as described above or if the clutch does not operate correctly, have a dealer check the internal clutch mechanism.

**Drive chain slack**

The drive chain slack should be checked before each ride and adjusted if necessary.

**To check the drive chain slack**

1. Place the ATV on a level surface.

**TIP**

When checking and adjusting the drive chain slack, there should be no weight on the ATV and all tires must be touching the ground.

2. Move the ATV back and forth to locate the tightest portion of the drive chain, and then measure the drive chain slack as shown.

Drive chain slack:  
45.0-55.0 mm (1.77-2.17 in)

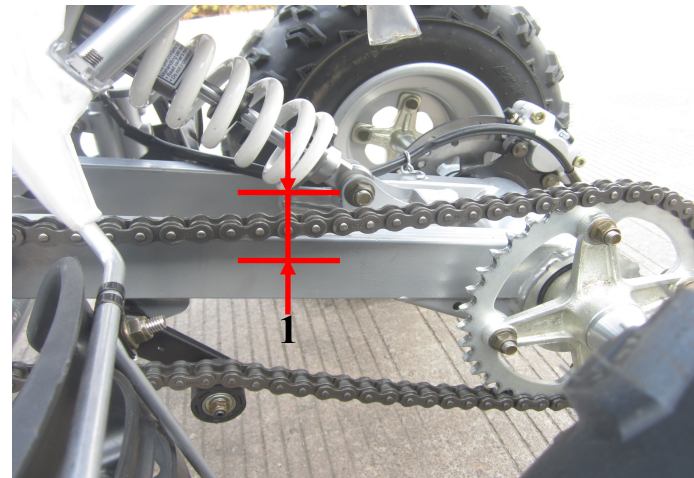

1. Drive chain slack

3. If the drive chain slack is incorrect, adjust it as follows.

### To adjust the drive chain slack

1. Place the ATV on a level surface.
2. Loosen the rear wheel axle pinch bolts.
3. Insert a rod of a diameter of 8 mm (0.3 in) and a length of 10 cm (4 in) into one of the holes in the drive chain tensioner as shown.

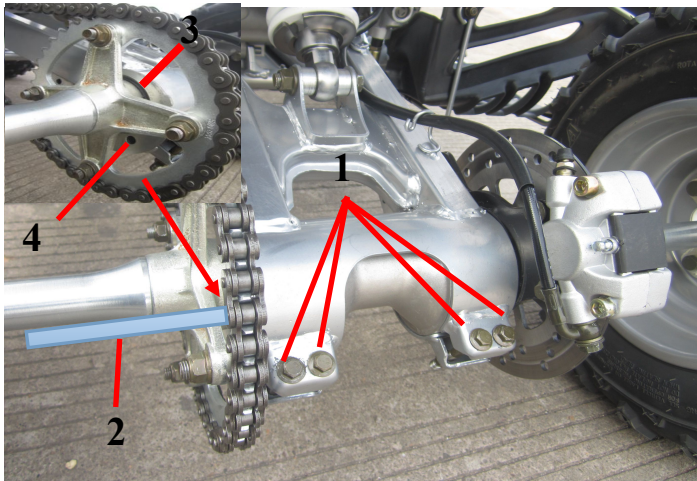

1. Rear wheel axle pinch bolt
2. Rod
3. Drive chain tensioner
4. Hole

### TIP

A rod can be obtained at a dealer to make this adjustment.

4. Shift the transmission into neutral.
5. To tighten the drive chain, push the ATV backward. To loosen the drive chain, push the ATV forward. **NOTICE: Improper drive chain slack will overload the engine as well as**

**other vital parts of the ATV and can lead to drive chain slippage or breakage. To prevent this from occurring, keep the drive chain slack within the specified limits.**

6. Pull the rod out, and then tighten the rear axle pinch bolts to the specified torque in the order shown.

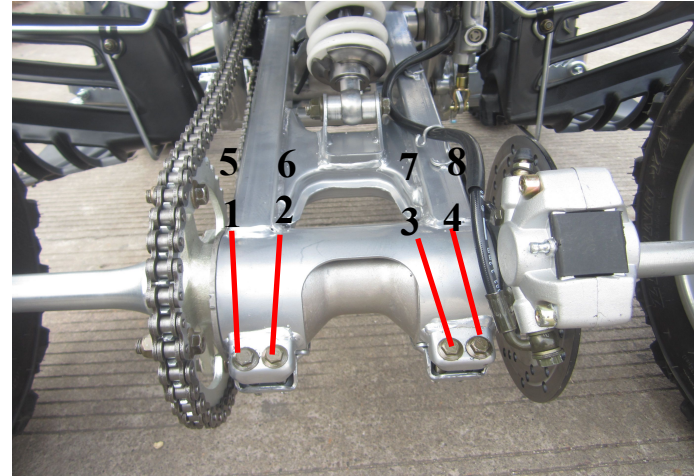

Tighten torque:

Rear axle pinch bolt:

21 Nm (2.1 m·kgf, 15ft ·lbf)

### Lubricating the drive chain

The drive chain must be cleaned and lubricated at the intervals specified in the periodic maintenance and lubrication chart, otherwise it will quickly wear out, especially when riding in dusty or wet areas.

Service the drive chain as follows.

### **NOTICE**

The drive chain must be lubricated after washing the ATV or riding in the rain or wet areas.

1. Clean the drive chain with kerosene and a small soft brush.
2. Wipe the drive chain dry.

### **Checking and lubricating the cables**

The operation and condition of all control cables should be checked before each ride, and the cables and cable ends should be lubricated if necessary.

If a cable is damaged or does not move smoothly, have a dealer check or replace it.

### **WARNING**

- Inspect cables frequently and replace if damaged. Corrosion can result when the cable sheaths become damaged, and cables can also become frayed or kinked, which could restrict the operation of controls and lead to an accident or injury.
- Always make sure all control cables work smoothly before you begin riding in cold weather. If the control cables are frozen or do not work smoothly, you could be unable to control the ATV, which could lead to an accident or collision.

### **Checking and lubricating the brake and clutch levers**

The operation of the brake and clutch levers should be checked before each ride, and the lever pivots should be lubricated if necessary.

#### **Brake lever**



#### **Clutch lever**



### Checking the shift pedal

The operation of the shift pedal should be checked before each ride. If operation is not smooth, have a dealer check the vehicle.

### Checking and lubricating the brake pedal

The operation of the brake pedal should be checked before each ride, and the pedal pivot should be lubricated if necessary.

### Checking the wheel hub bearings

The front and rear wheel hub bearings must be checked at the intervals specified in the periodic maintenance and lubrication chart. If there is play in a wheel hub or if a wheel does not turn smoothly, have a dealer check the wheel hub bearings.



### Lubricating the swing arm pivots

The swing arm pivots must be lubricated by a dealer at the intervals specified in the periodic maintenance and lubrication chart.

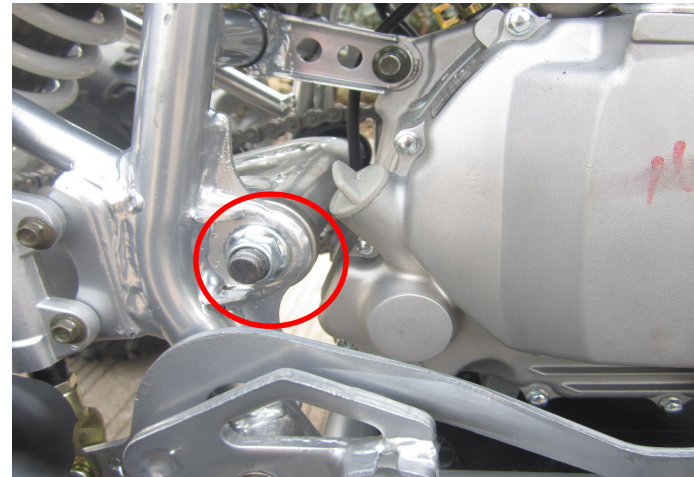

### Lubricating the upper and lower arm pivots

The upper and lower arm pivots must be lubricated at the intervals specified in the periodic maintenance and lubrication chart.

### TIP

For parts equipped with a grease nipple, use a grease gun.

## Left side

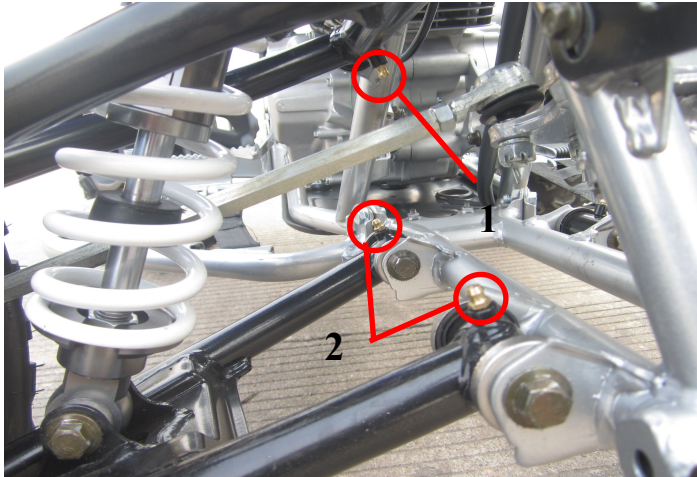

1. Upper grease nipple
2. Lower grease nipple

## Right side

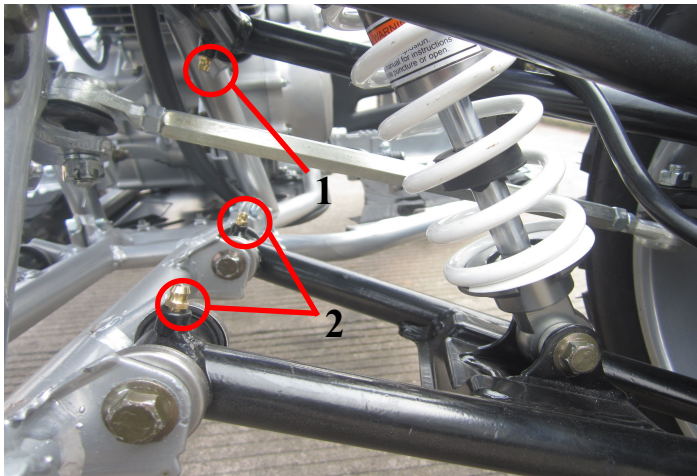

1. Upper grease nipple
2. Lower grease nipple

## Lubricating the steering shaft

The steering shaft must be lubricated by a dealer at the intervals specified in the periodic maintenance and lubrication chart.

### TIP

For parts equipped with a grease nipple, use a grease gun.

## Battery

The battery is located under the seat.

This model is equipped with a Valve Regulated Lead Acid battery. There is no need to check the electrolyte or to add distilled water. However, the battery lead connections need to be checked and, if necessary, tightened.

## WARNING

**Battery electrolyte is poisonous and dangerous, as it contains sulfuric acid, which can cause severe burns. Avoid contact with skin, eyes or clothing. Always shield your eyes when working near batteries.**

**Antidote:**

**EXTERNAL:** Flush with water.

**INTERNAL:** Drink large quantities of water or milk. Follow with milk of magnesia, beaten egg or vegetable oil. Call a physician immediately.

**EYES:** Flush with water for 15 minutes and get prompt medical attention.

**Batteries produce explosive gases. Keep sparks, flame, cigarettes or other sources of ignition away. Ventilate when charging or using in an enclosed space.**

**KEEP OUT OF REACH OF CHILDREN.**

**NOTICE**

**Never attempt to remove the battery cell seals, as this would permanently damage the battery.**

**To remove the battery**

1. Remove the seat.
2. Unhook the band securing the owner's tool kit, and then remove the battery holding plate by removing the bolts.

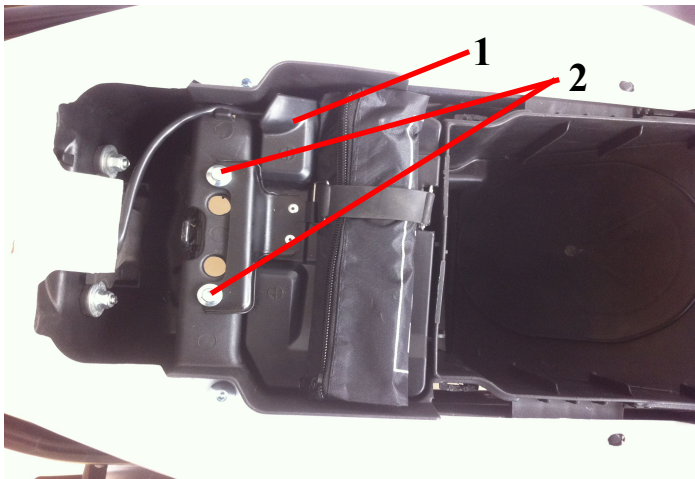

1. Battery holding plate
2. Bolt

3. Disconnect the negative battery lead first, then the positive battery lead by removing their bolt. **NOTICE: When removing the battery, the main switch must be off, and the negative lead must be disconnected before the positive lead.**

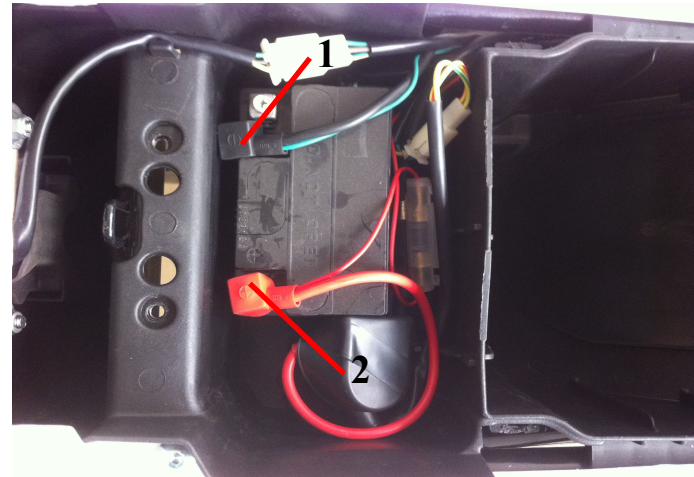

1. Negative battery lead (black)
2. Positive battery lead (red)

4. Pull the battery out of its compartment.

**To charge the battery**

Have a dealer charge the battery as soon as possible if it seems to have discharged. Keep in mind that the battery tends to discharge more quickly if the ATV is equipped with optional electrical accessories.

**NOTICE**

**To charge a battery, a special (constant-voltage) battery charger is required. Using a conventional battery charger will damage the battery.**

### To store the battery

- If the ATV will not be used for more than one month, remove the battery, fully charge it, and then place it in a cool, dry place.
- If the battery will be stored for more than two months, check it at least once a month and fully charge it if necessary.

### **NOTICE**

**Always keep the battery charged. Storing a discharged battery can cause permanent battery damage.**

### To install the battery

#### TIP

Be sure the battery is fully charged.

1. Place the battery in its compartment.
2. Connect the positive battery lead first, then connect the negative battery lead by installing their bolt. **NOTICE:** **When installing the battery, the main switch must be off, and the positive lead must be connected before the negative lead.**
3. Install the battery holding plate by installing the bolts, and then hook the band to secure the owner's tool kit.
4. Install the seat.

### Replacing the fuse

The fuse holder is located beside the battery and can be accessed as follows:

1. Remove the seat.
2. Unhook the band securing the owner's tool kit, and then remove the battery holding plate by removing the bolts.

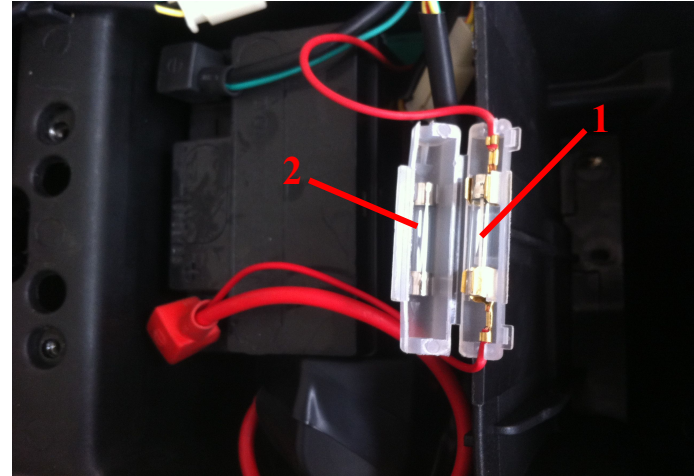

1. Fuse
2. Spare fuse

If the fuse is blown, replace it as follows.

1. Turn the key to "OFF" and turn off all electrical circuits.

### **NOTICE**

**To prevent accidental short-circuiting, turn off the main switch when checking or replacing a fuse.**

2. Remove the blown fuse, and then install a new fuse of the specified amperage.

**WARNING! Always use a fuse of the specified rating, and never use a substitute object in place of the proper fuse. An improper fuse or substitute object can cause damage to the electrical system, which could lead to a fire.**

Specified fuse: Fuse: 10.0 A
------------------------------------

3. Turn the key to "ON" and turn on the electrical circuits to check if the devices operate.
4. If the fuse immediately blows again, have a dealer check the electrical system.
5. Install the battery holding plate by installing the bolts, and then hook the band to secure the owner's tool kit.
6. Install the seat.

### Replacing a headlight bulb

If a headlight bulb burns out, replace it as follows.

1. Remove the headlight unit by removing the bolt.

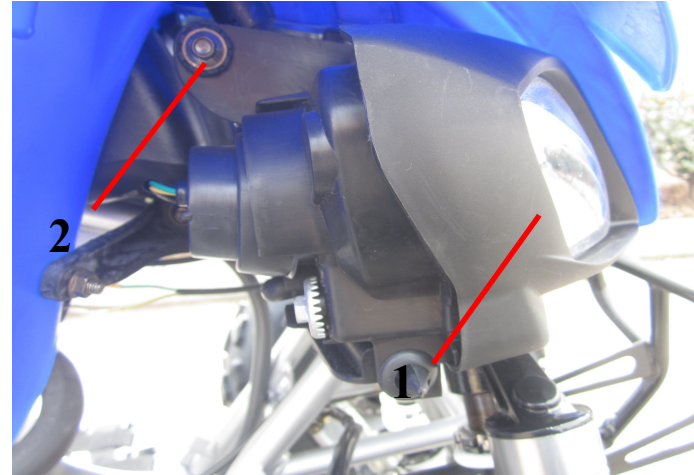

1. Headlight unit
2. Bolt
2. Disconnect the headlight coupler.
3. Remove the headlight bulb holder cover.

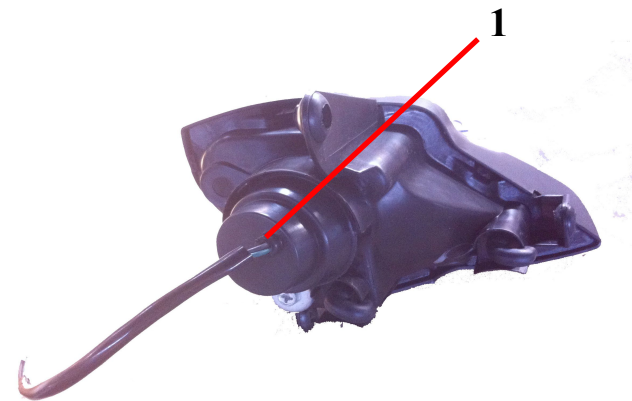

1. Headlight bulb holder cover

4. Remove the headlight bulb holder by pushing it in and turning it counterclockwise, and then remove the burnt-out bulb.

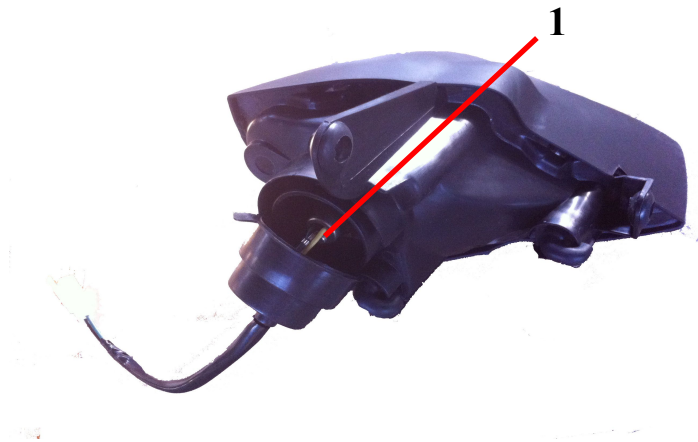

1. Headlight bulb holder

5. Place a new headlight bulb into position.

**NOTICE:** Do not touch the glass part of the headlight bulb to keep it free from oil, otherwise the transparency of the glass, the luminosity of the bulb, and the bulb life will be adversely affected. Thoroughly clean off any dirt and fingerprints on the headlight bulb using a cloth moistened with alcohol or thinner.

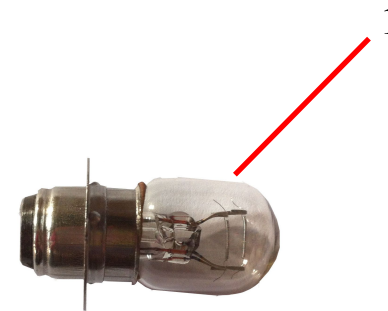

1. Do not touch the glass part of the bulb.

6. Install the headlight bulb holder by pushing it in and turning it clockwise.
7. Install the headlight bulb holder cover.
8. Connect the headlight coupler.
9. Install the headlight unit by installing the bolt.
10. Adjust the headlight beam if necessary.

### Adjusting a headlight beam

#### **NOTICE**

**It is advisable to have a dealer make this adjustment.**

To raise a headlight beam, turn the headlight beam adjusting bolt counter-clockwise.

To lower a headlight beam, turn the adjusting bolt clockwise.

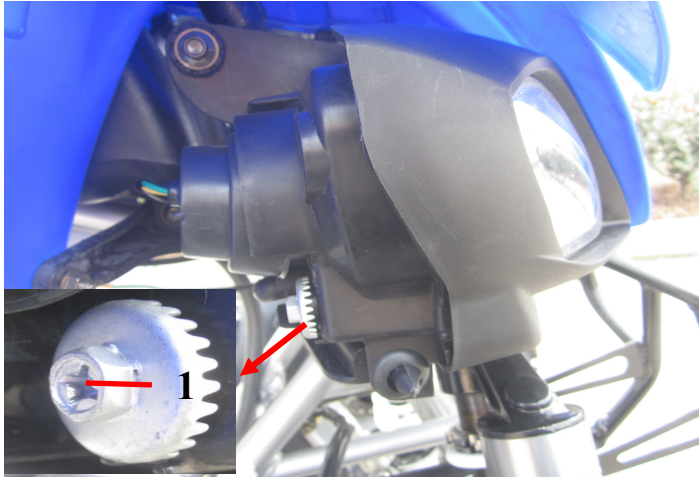

1. Headlight beam adjusting bolt

### Replacing the tail/brake light bulb

If the tail/brake light bulb burns out, have a dealer replace it.

### Removing a wheel

1. Place the ATV on a level surface.
2. Loosen the wheel nuts.

### Front

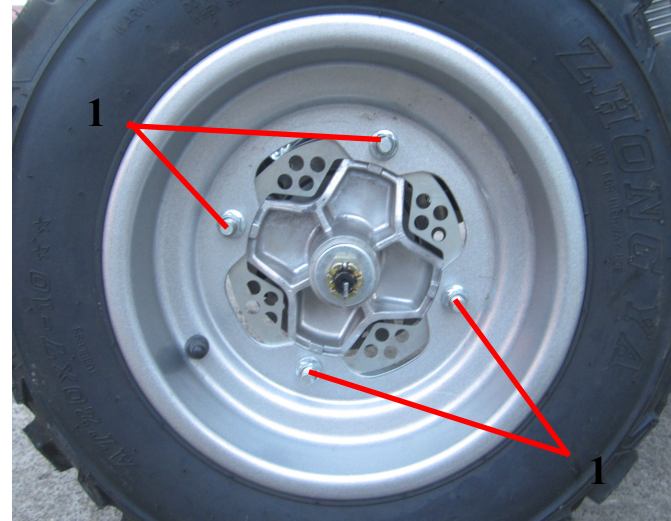

1. Wheel nut

### Rear

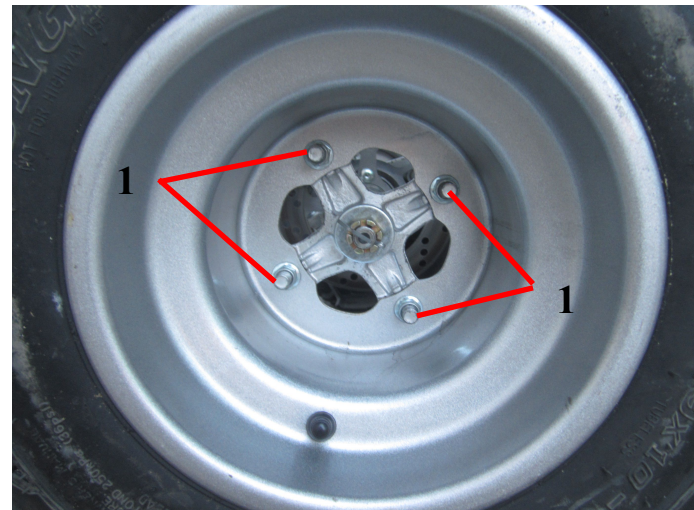

1. Wheel nut

3. Elevate the ATV and place a suitable stand under the frame.
4. Remove the nuts from the wheel.
5. Remove the wheel.

### **Installing a wheel**

1. Place the ATV on a level surfaces.
2. Install the wheel and nuts.
3. Lower the ATV to the ground.
4. Tighten the wheel nuts to the specified torques.

Tightening torques:

Front wheel nut:

45 Nm (4.5 m·kgf, 33 ft·lbf)

Rear wheel nut:

45 Nm (4.5 m·kgf, 33 ft·lbf)

### **WARNING**

**Do not smoke when checking the fuel system. Fuel can ignite or explode, causing severe injury or property damage. Make sure there are no open flames or spark in the area, including pilot lights from water heaters or furnaces.**

### **Troubleshooting**

Although the ATVs receive a thorough inspection before shipment from the factory, trouble may occur during operation.

Any problem in the fuel, compression, or ignition systems, for example, can cause poor starting and loss of power.

The following troubleshooting chart represents a quick and easy procedure for checking these vital systems yourself. However, should your ATV require any repair, take it to a dealer, whose skilled technicians have the necessary tools, experience, and know-how to service the ATV properly. Use only original replacement parts.

## Troubleshooting chart

### 1. Fuel

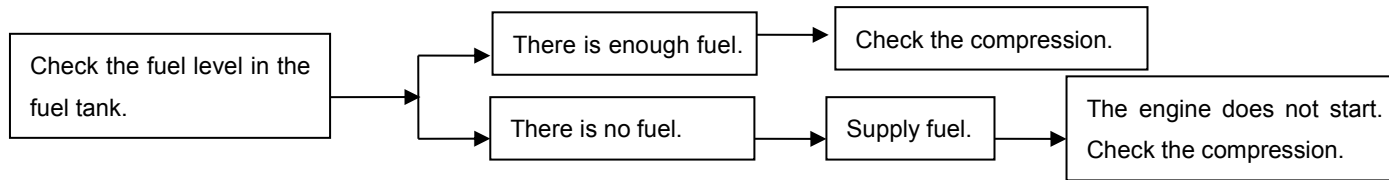

### 2. Compression

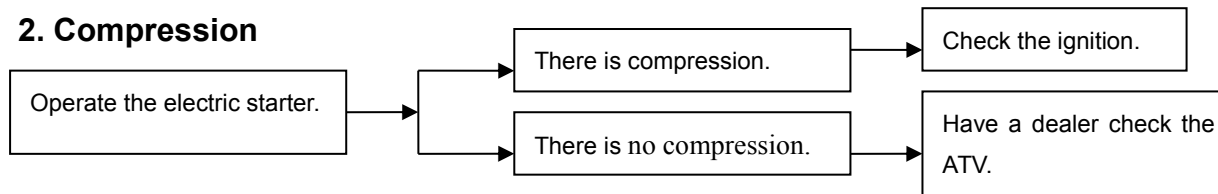

### 3. Ignition

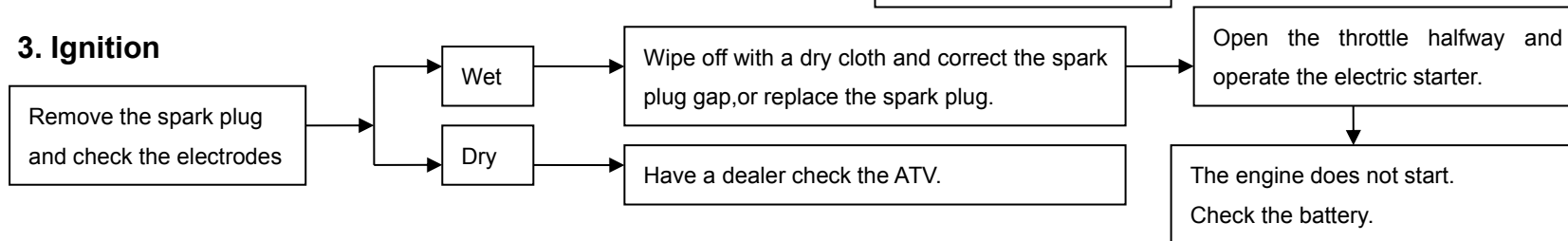

### 4. Battery

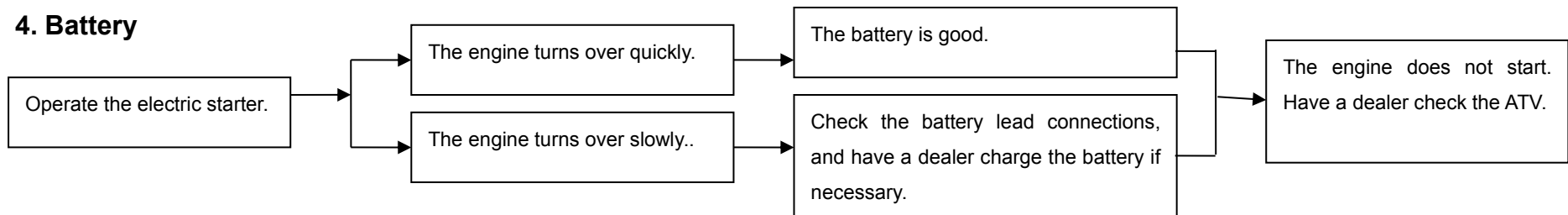

## CLEANING AND STORAGE

### Cleaning

Frequent, thorough cleaning of your ATV will not only enhance its appearance but will improve its general performance and extend the useful life of many components.

1. Before cleaning the ATV:
  - a. Block off the end of the exhaust pipe to prevent water entry. A plastic bag and strong rubber band may be used.
  - b. Make sure the spark plug and all filler caps are properly installed.
2. If the engine case is excessively greasy, apply degreaser with a paint brush. Do not apply degreaser to the chain, sprockets or wheel axles.
3. Rinse the dirt and degreaser off with a garden hose. Use only enough pressure to do the job.

**WARNING! Wet brakes may have reduced stopping ability, increasing the chance of an accident. Test the brakes after washing. Apply the brakes several times at slow speeds to let friction dry out the linings.**

**NOTICE: Excessive water pressure may cause water**

**Seepage and deterioration of wheel bearings, brakes, transmission seals and electrical devices. Many expensive repair bills have resulted from improper high-pressure detergent applications such as those available in coin-operated car washers.**

4. Once most of the dirt has been hosed off, wash all surfaces with warm water and mild, detergent-type soap. An old toothbrush or bottle brush is handy for hard-to-reach places.
5. Rinse the ATV off immediately with clean water and dry all surfaces with a chamois, clean towel or soft absorbing cloth.
6. Dry the chain and lubricate it to prevent it from rusting.
7. Clean the seat with a vinyl upholstery cleaner to keep the cover pliable and glossy.
8. Automotive type wax may be applied to all painted and chrome plated surfaces. Avoid combination cleaner-waxes. Many contain abrasives which may mar the paint or protective finish. When finished cleaning, start the engine and let it idle for several minutes.

## Storage

### Short-term

Always store your ATV in a cool, dry place and, if necessary, protect it against dust with a porous cover. **NOTICE: Storing the ATV in a poorly ventilated room or covering it with a tarp while it is still wet, will allow water and humidity to seep in and cause rust. To prevent corrosion, avoid damp cellars, stables (because the presence of ammonia) and areas where strong chemicals are stored.**

### Long-term

Before storing your ATV for several months:

1. Follow all the instructions in the “Cleaning” section of this chapter.
2. Turn the fuel cock lever to “OFF”.
3. Drain the carburetor float chamber by loosening the drain bolt; this will prevent fuel deposits from building up. Pour the drained fuel into the fuel tank.
4. Fill up the fuel tank and add fuel stabilizer (if available) to prevent the fuel from deteriorating.
5. Perform the following steps to protect the cylinder, piston rings, etc. from corrosion.
  - a. Remove the spark plug cap and spark plug.
  - b. Pour a teaspoonful of engine oil into the spark plug bore.
  - c. Install the spark plug cap onto the spark plug, and then place the spark plug on the cylinder head so that the electrodes are grounded. ( This will limit sparking during the next step.)
  - d. Turn the engine over several times with the starter. (This will coat the cylinder wall with oil.)
  - e. Remove the spark plug cap from the spark plug and then install the spark plug and the spark plug cap.
6. Lubricate all control cables and the pivoting points of all levers and pedals.
7. Check and, if necessary, correct the tire air pressure, and block up the ATV so that all of its wheels are off the ground. Alternatively, turn the wheels a little every month in order to prevent the tires from becoming degraded in one spot.
8. Cover the muffler outlet with a plastic bag to prevent moisture from entering it.
9. Remove the battery and fully charge it. Store it in a cool, dry place and charge it once a month. Do not store the battery in an excessively cold or warm place [less than 0 °C (30 °F) or more than 30 °C (90 °F)].

### TIP

Make any necessary repairs before storing the ATV.

## SPECIFICATIONS (AIR COOLED ENGINE)

L×W×H	1625×1060×1065
Wheelbase	1090±20mm
Front wheelbase	820mm
Rear wheelbase	830mm
Ground clearance	135±15mm
Seat height	790±15 mm
Chassis clearance	225mm
Handle height	1000mm
Carton size:L×W×H	1460×880×860 mm
Front suspension travel	70mm
Rear suspension travel	80mm
Minimum steering radius	5900±500mm
Steering angle	<45°
Sideslip	<5m/km
Max load	100kg
Net weight	149kg
Gross weight	177kg
Brake/Front &Rear	Hydraulic brake
Brake type/ Front &Rear	Hand brake& foot brake
Wheel / Front &Rear	10×5.5AT/9×8.0AT
Tire /Front &Rear	AT 20×7.0-10/AT 19×10-9
Tire air pressure /Front &Rear	36PSI
Drive Train	Chain

Engine type	ZS169FMM
Engine model	single cylinder, 4-stroke, air-cooled
Manufacturer	ZONGSHEN
Cylinder bore×stroke	69×62.2mm
Displacement	232.6ml
Compression ratio	(8.3~8.9):1
Output, Rated	/
Output, Max	12 (1±5%) kw /7500 (1±5%) rpm
Torque, Max	17 (1±5%) N·m /6000 (1±5%) rpm
Idling speed	1400(1±10%) r/min
Fuel Consumption rate	354g / kw.h
Fuel type	≥RQ90
Lubrication	Pressure, Splash
Lubricating oil type	SF15W/40
Clutch type	Manual, wet multiplate clutch

## SPECIFICATION(WATER COOLED ENGINE)

Start	Electric start	
Ignition	CDI	
Carburetor	PZ30	
Spark plug	D8TC	
Battery	12V, 7HA	
Front lamp bulb	12V18-18W	
Max speed	90km/h	
Start ability	15S	
Brake ability	Front	≥60%
	Rear	≥55%
Brake balance	Front	≤20%
	Rear	≤24%
Climb ability	21°	
Parking ability	≥18°	
Exhaust	CO(%)	≤3.8
	HC(PPm)	≤800
Max noise	≤82 dB(A)	
Starting acceleration ability	≤6.8 S	
Passing acceleration ability	≤6.8 S	
Fuel tank capacity	9L	
Front& Rear suspension	Oil damper with air-cell adjustable/Oil damper	
Exhaust muffler model	Cartridge impedance compound muffler	
Front& Rear suspension length	L=350mm/ L=390mm	

L×W×H	1625×1060×1065
Wheelbase	1090±20mm
Front wheelbase	820mm
Rear wheelbase	830mm
Ground clearance	135±15mm
Seat height	790±15 mm
Chassis clearance	225mm
Handle height	1000mm
Carton size:L×W×H	1460×880×860 mm
Front suspension travel	70mm
Rear suspension travel	80mm
Minimum steering radius	5900±500mm
Steering angle	<45°
Sideslip	<5m/km
Max load	100kg
Net weight	149kg
Gross weight	177kg
Brake/Front &Rear	Hydraulic brake
Brake type/ Front &Rear	Hand brake& foot brake
Wheel / Front &Rear	10×5.5AT/9×8.0AT
Tire /Front &Rear	AT 20×7.0-10/AT 19×10-9
Tire air pressure /Front &Rear	36PSI
Drive Train	Chain

Engine type	ZS169MM
Engine model	single cylinder, 4-stroke, water-cooled, single overhead camshaft
Manufacturer	ZONGSHEN
Cylinder bore×stroke	69×65mm
Displacement	243.1ml
Compression ratio	(9.8~10.7):1
Output, Rated	/
Output, Max	11.5 (1±5%) kw /7000 (1±5%) rpm
Torque, Max	19 (1±5%)N • m /5000 (1±5%) rpm
Idling speed	1400(1±10%) r/min
Fuel Consumption rate	354g / kw.h
Fuel type	≥RQ90
Lubrication	Pressure, Splash
Lubricating oil type	SF15W/40
Clutch type	Manual, wet multiplate clutch

Start	Electric start	
Ignition	CDI	
Carburetor	PZ30	
Spark plug	D8TC	
Battery	12V, 7HA	
Front lamp bulb	12V18-18W	
Max speed	85km/h	
Start ability	15S	
Brake ability	Front	≥60%
	Rear	≥55%
Brake balance	Front	≤20%
	Rear	≤24%
Climb ability	21°	
Parking ability	≥18°	
Exhaust	CO(%)	≤3.8
	HC(PPm)	≤800
Max noise	≤82 dB(A)	
Starting acceleration ability	≤8 S	
Passing acceleration ability	≤8 S	
Fuel tank capacity	9L	
Front& Rear suspension model	Oil damper with air-cell adjustable/Oil damper	
Exhaust muffler model	Cartridge impedance compound muffler	
Front& Rear suspension length	L=350mm/ L=390mm	