

Electric Scooter X3

User Manual

FUNBIKES

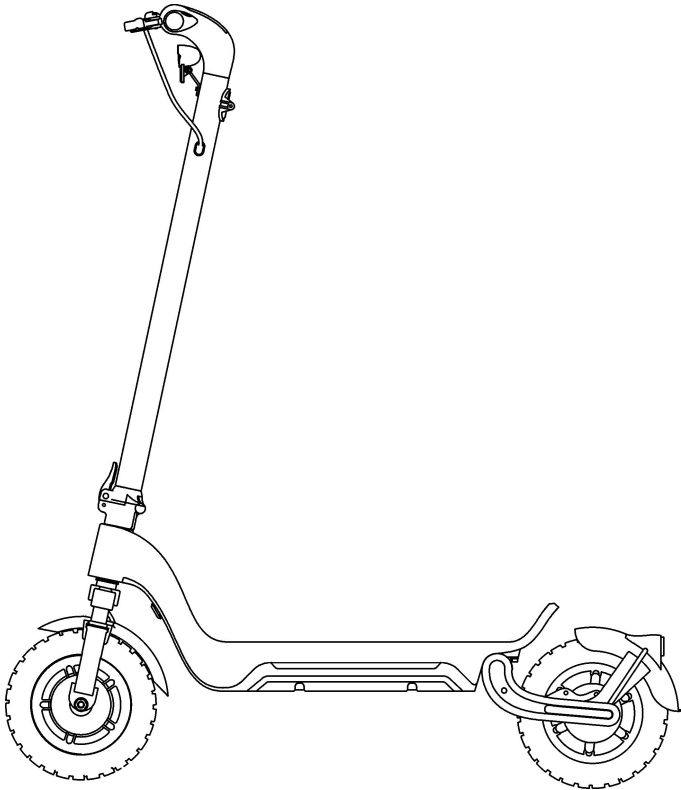

**UK
CA**

Contents

1 Riding Safety -----	02
2 Packing List -----	05
3 Diagram -----	06
4 Assembling Your Electric Scooter -----	07
5 First Ride -----	09
6 Charging -----	10
7 Learning to Ride -----	11
8 Warnings -----	13
9 Maintenance -----	15
10 Certifications -----	17

Thanks for choosing the Electric scooter!

Your Electric scooter is a recreational product with mobile app ,allowing you to connect with other riders Enjoy your ride and connect with riders worldwide

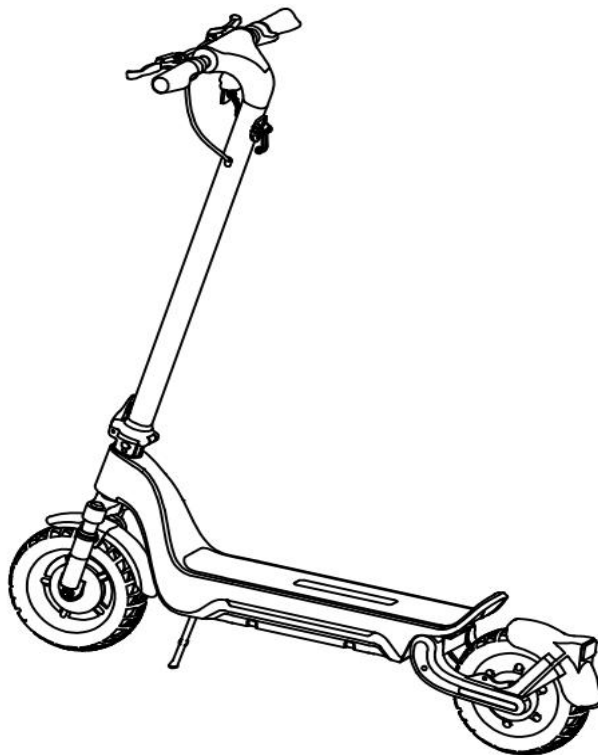

1 Riding Safety

1. The Electric scooter is a recreational product. Before mastering riding skills you need to be responsible for any injuries or damage caused by a rider's inexperience or failure to follow the instructions in this document.

2. Please understand that you can reduce the risk by following all the instructions and warnings in this manual, but you cannot eliminate all the risks. Remember that whenever you ride the Electric scooter you risk injury from loss of control, collisions, and falls. When entering into public spaces always comply with the local laws and regulations. As with other vehicles, faster speeds require longer braking distance. Sudden braking on low traction surfaces could lead to wheel slip or falls. Be cautious and always keep a safe distance between you and other people or vehicles when riding. Be alert and slow down when entering unfamiliar areas.

3. Always wear a helmet when riding. Use an approved bicycle or skateboard helmet that fits properly with the chin strap in place and provides protection for the back of your head.

4. Do not attempt your first ride in any area where you might encounter children, pedestrians, pets, vehicles, bicycles, or other obstacles and potential hazards.

5. Respect pedestrians by always yielding the right of way. Pass on the left whenever possible. When approaching a pedestrian

from the front. stay to the right and slow down. Avoid startling pedestrians. When approaching from behind announce yourself and slow down to walking speed when passing. Please obey local traffic laws and regulations if situation is different.

6. In places without laws comply with the safety guidelines outlined in this manual user is responsible for any property damage ,personal injury/death,accidents,or legal disputes caused by violations of the safety Instructions.

7. Do not allow anyone to ride your Electric scooter on his/her own unless they have carefully read this manual and followed the New Rider Tutorial in the App. The safety of new riders is your responsibility. Assist new riders until they are comfortable with the basic operation of the Electric scooter ,Make sure each new rider wears a helmet and other protective gear .

8. Before each ride check for loose fasteners and damaged components. If the Electric scooter makes abnormal sounds or signals an alarm,immediately stop riding Diagnose your Electric scooter call your dealer/distributor for service.

9.Be alert! Scan both far ahead and in front of your Electric scooter-your eyes are your best tool for safely avoiding obstacles and low traction surfaces(including but not limited to,wet ground,loose sand.loose gravel,and ice).

10.To reduce risk of injury. you must read and follow all"CAUTION and WARNING notices in this document.Do not ride at an unsafe speed. Under no circumstance should you ride on

roads with motor vehicles. The manufacturer recommends riders be 16+ year old. Always follow these safety instructions.

A. People who should not ride the Electric Scooter include

- i. Anyone under the influence of alcohol or drugs
- i. Anyone who suffers from disease that puts them at risk if they engage in strenuous physical activity
- ii. Anyone who has problems with balance or with motor skills that would interfere with their ability to maintain balance
- v. Anyone whose weight is outside the stated limits (Maximum bearing weight 100kg)

Vi. Pregnant women

B. Riders under the age of 18 years old should ride under adult supervision

C. Comply with local laws and regulations when riding this product. Do not ride where prohibited by local laws

D. To ride safely, you must be able to clearly see what is in front of you and you must be clearly visible to others

E. Do not ride in the snow, in the rain, or on roads which are wet, muddy, icy, or that are slippery for any reason

Do not ride over obstacles (sand, loose gravel, or sticks). Doing so could result in a loss of balance or traction and could cause a fall

11. Do not attempt to charge your Electric scooter if, the charger, or the power outlet is wet

12. As with any electronic device, use a surge protector when charging to help protect your Electric scooter from damage due to power surges and voltage spikes. Only use only the matching charger in the vehicle package. Do not use a charger from any other different product models

13. Use only approved parts and accessories. Do not modify your Electric scooter. Modifications to your Electric scooter could

interfere with the operation of the Electric scooter,could result in serious injury and/or damage,and could void the Limited Warranty.

2 Packing List

Assembled Electric Scooter

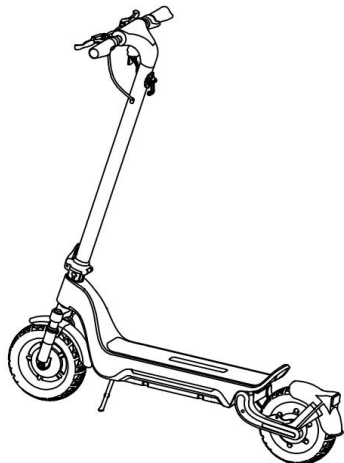

- User Manual x1
- tool kit x1
- Headlamp gasket x1
- Hook x1
- Charger x1

When unpacking your Electric scooter. Please verify that the above items are included in the package.If you are missing any components,please contact your dealer/distributor or nearest service center.After verifying that all components are present and in good condition you can assemble your new Electric scooter Please retain the box and packing materials in case you need to ship your Electric scooter in the future Remember to power off your

Electric scooter and unplug the power card before assembling mounting accessories, or cleaning the mainframe.

3 Diagram

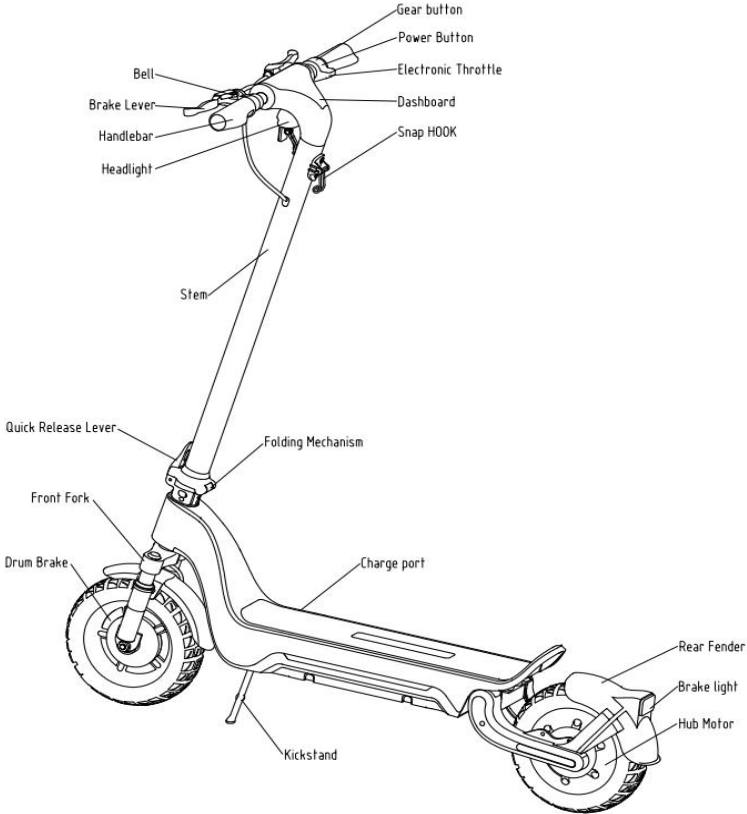

Dashboard&Power Button

Speedometer Display the current speed of the Electric scooter, as well as to display error codes

Modes: Three modes available "" for Energy saving mode (smooth acceleration suitable for beginners), D for Standard mode and S "" for Sport mode (powerful, only recommended for skilled riders)

Pedestrian mode: Makes pushing the Electric scooter easier.

Bluetooth The icon indicates that the Electric scooter has been successfully connected to the mobile device

Error The wrench icon indicates that the Electric scooter has detected an error Battery Level. The battery powers indicated by 4 bars, The first bar is about 40% of the battery power, and the remaining 20% of the battery power is per bar.

Power button press this button to turn on the electric scooter, press the gear button, click to turn on the light, and double-click to switch gears between modes. The power button for 3 seconds turns off the electric scooter when it is turned on.

4 Assembling Your Electric scooter

1 Unfold the handlebar stem and fasten

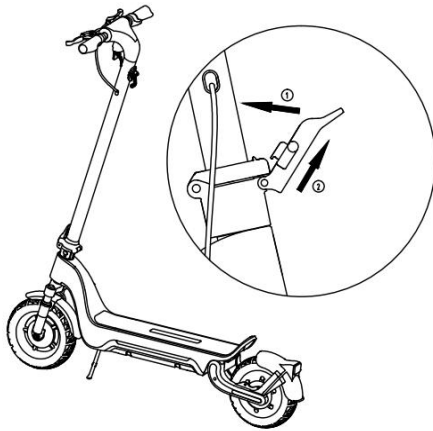

2 Firmly connect the wires inside the it. Then unfold the kickstand to handle and the stem.Slide the handle support the Electric scooter. onto the stem.Be aware of the correct orientation.

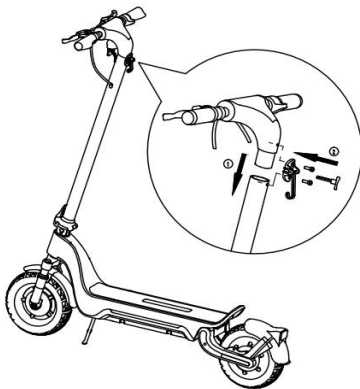

3 Install seven screws (two on each side,

4 Verify that your Electric scooter can two hook holes and one headlight powered on and off.

hole) on the connected hexagon wrench.

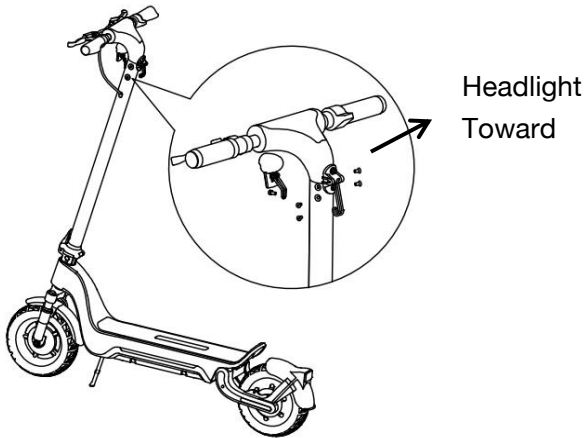

Android



IOS

5 First Ride

There are safety risks when learning to ride the Electric scooter, You must read the Riding Safety via the App before your first ride. For your safety, your new Electric scooter is not activated and will beep occasionally after Power ON.

Until activated, the Electric scooter maintains very low riding speed, and cannot be ridden with full function. Install the App on your mobile device (with Bluetooth 4.0 or above).

connect to the Electric scooter with Bluetooth, and follow the App instructions to activate your Electric Scooter and enjoy the full performance APP. Scan the QR code to download the App.

1 Install the App and register/login.

2 Power on the Electric scooter. A blinking Bluetooth icon indicates the Electric scooter is waiting for a connection.

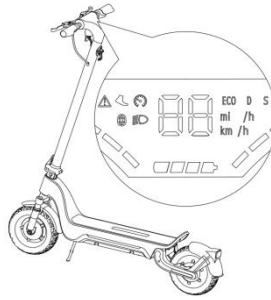

3 Click "Vehicle"-Scan for Vehicle"to connect to Your Electric scooter.

when the connection is successful.

The Bluetooth icon will stop blinking and remain illuminated

4 Follow the App instructions to activate the Electric scooter and learn how to ride safely You can now start to use your Electric scooter.check the status with App,and interact with other users.Have fun!

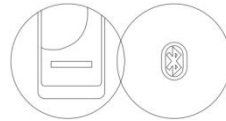

6 Charging

Charging step tips

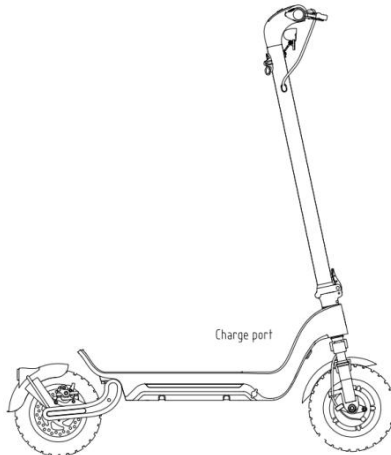



Open the
charging port



Plug in
the charger



Cover the
waterproof cover

WARNING!

Do not charge if the charge port or power cord is wet.

Do not charge or use your battery if it is damaged or see trace of water.

Close the charge port cover when not charging.

7 Learning to Ride



Wear an approved helmet and other protective gear to minimize any

possible injury.

1 .Power on the Electric scooter and check the power level indicator
Charge the Electric scooter if the battery even is slow

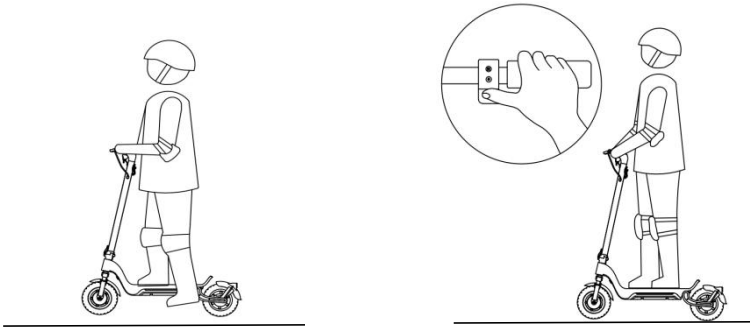

2. Stand on the footrest with one foot and push off with another foot to start gliding.

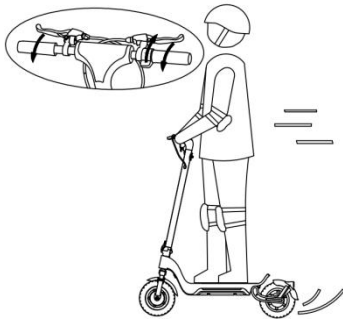

3. Put your other foot on the footrest to keep both feet stable, Press the throttle Starts sliding. On the right hand to speed up when you are

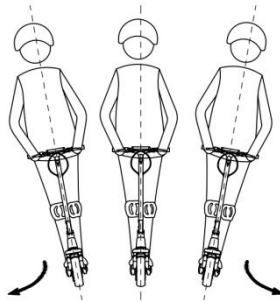

▲ WARNING

When hard braking,you risk serious injury due to loss of traction and falls.

Maintain a moderate speed and look out for potential hazards.

8 Warnings

WARNING

Failure to follow these instructions could lead to serious Injury.



DO NOT ride the speed bumps, thresholds, Kick scooter in the rain.

DO NOT GET Wet.

DO NOT ride over Or other bumps at HIGH

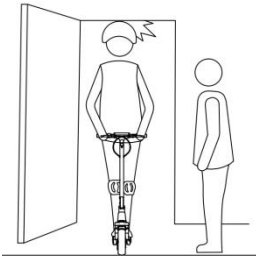

Watch your head when passing through doorways.

Do not keep your feet on the rear

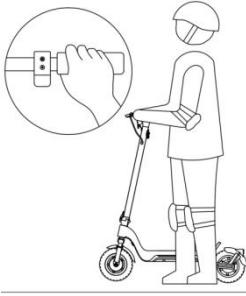

DO NOT press throttle when walking the walking with the Electric scooter.

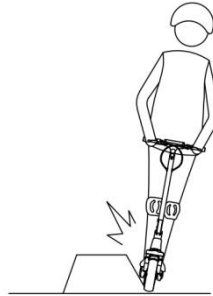

Avoid contacting obstacles with

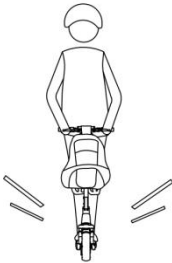

DO NOT carry heavy objects on the scooter with Handlebar.

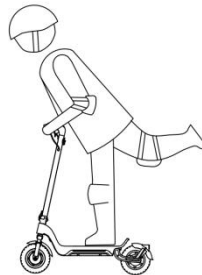

DO NOT ride the Electric only one foot.

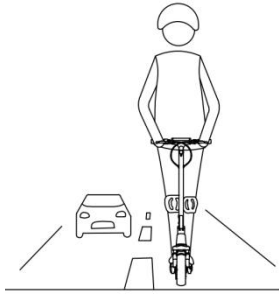

DO NOT ride on public roads.
Motorways, or highways. while

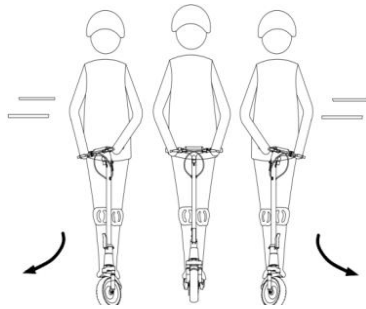

DO NOT rotate the handle violently
While driving at high speed



DO NOT ride through puddles
other bodies of water.

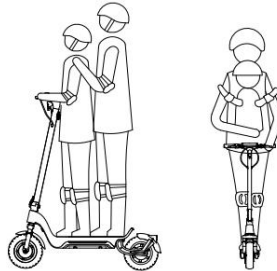

The Electric scooter is for one rider
only Do not carry any passengers.
Do not carry a child.
Do when pregnant not ride

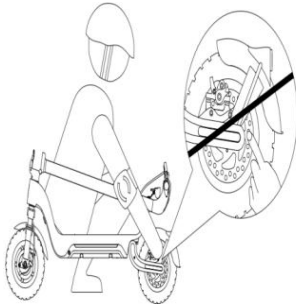

DO NOT touch the hub motor after riding because it can get

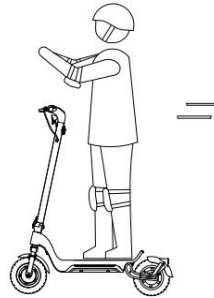

Do not leave the handlebars with both hands

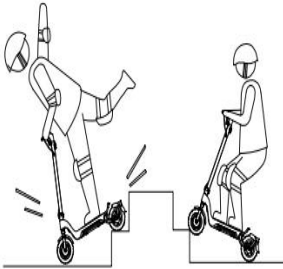

DO NOT ride up and down stairs or jump over obstacles.

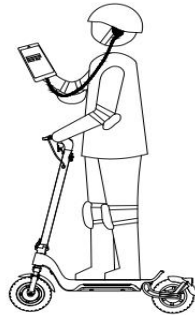

DO not use mobile phone or wear when operating the Electric scooter.

WARNING

Always keep both hands on the handlebar or you risk serious injury due to loss of balance and falls.



WEEE Disposal and Recycles Information Correct Disposal of this product. This marking indicates that this product should not be disposal with other household wastes throughout the EU.

To prevent possible harm to the environment or human health from uncontrolled waste disposal, recycle it responsible to promote the sustainable reuse of materials resources. To return your used device, please use the return and collection systems or contact the retailer where the product was purchased. They can take this product for environmental safe recycling.

Battery recycling information for the European Union



Batteries or packaging for batteries are labeled in accordance with European Directive 2006/66/EC and amendment 2013/56/EU concerning batteries and accumulators and waste batteries and accumulators. The Directive determines the framework for the return and recycling of used batteries and accumulators as applicable throughout the European Union. This label is applied to various batteries to indicate that the battery is not to be thrown away, but rather reclaimed upon end of life per this Directive.

In accordance with the European Directive 2006/66/EC and amendment 2013/56/EU, batteries and accumulators are labeled to indicate that they are to be collected separately and recycled at end of life. The label on the battery may also include a chemical symbol for the metal concerned in the battery (Pb for lead, Hg for mercury and Cd for cadmium)

Users of batteries and accumulators must not dispose of batteries and accumulators as unsorted municipal waste, but use the collection framework available to customers for the return, recycling, and treatment of batteries and accumulators. Customer participation is important to minimize any potential effects of batteries and accumulators at the environment and human health due to the potential presence of hazardous substances

Before placing electrical and electronic equipment (EEE) in the waste collection stream or in waste collection facilities, the end user of equipment

containing batteries and/or accumulators must remove those batteries and accumulators for separate collection.