



**M2R
RACING**

QUANTITY AND PERFORMANCE

DK50

DT110

DK110 MOTARD

DK60

DT125

DT125 MOTARD

DK70

DT140

DT140 MOTARD

DK90

DT155

DT155 MOTARD

DK110

DT190

DA250

WWW.MADE2RACE.CO.UK
WWW.FUNBIKES.CO.UK

DK60

DK60



DK70

DK70



DK90/110/125

DK110/125



DK125MOTAD

DK125 MOTARD



DT125/140/155/190

DK125/140/150



DT125MOTAD

DT125 Motard



Owner's Manual

This manual should be considered a permanent part of the motorcycle and should remain if it is resold.

This manual contains the latest product information available before printing. M2R reserves the right to make changes at any time without notice and without incurring any obligation.

No part of this publication may be reproduced without written permission.

IMPORTANT

PLEASE READ THIS MANUAL CAREFULLY AND COMPLETELY BEFORE GOING ON YOUR FIRST RIDE. IT CONTAINS A GREAT DEAL OF

Please write the serial numbers of your motorcycle in the boxes below

Chassis (VIN) Number

Engine Number

Key Number (If Available)

Dealer Stamp

CONSUMER INFORMATION FOR UNITED STATES

Tampering with noise & emissions control systems is prohibited

Owners are warned that the law prohibits:

- A.** The removal or rendering inoperative by any person other than for purposes of maintenance, repair or replacement, of any device or element of design incorporated into any new vehicle for the purpose of noise and/or emissions control prior to its sale or delivery to the ultimate purchaser or while it is in use; and
- B.** The use of the vehicle after such device or element of design has been removed or rendered inoperative by any person.

M2R reserves the right to modify any equipment, technical specifications, colors, materials, services offered and rendered, and the like so as to adapt them to local conditions without previous announcement and without giving reasons, or to cancel any of the above items without substituting them with others. It shall be acceptable to stop manufacturing a certain model without prior notice. In the event of such modifications, please ask your local M2R dealer for information.

LIMITED WARRANTY

WHAT IS COVERED: M2R warrants that this product is free of defects in material and workmanship for a period of 6 months from the date of purchase, except as limited below. Warranty service and replacement parts are warranted only for the duration of the warranty on the original product. The warranty coverage is for the following:

- Engine and drive train – 6 Months
- Front suspension – 6 Months
- Rear suspension – 6 Months
- Frame and swing-arm – 1 Year

WHAT IS NOT COVERED: This warranty does not cover any conditions caused by misuse, neglect, negligence, accident operation in any way contrary to the operating instructions in the owner's manual, normal wear, alteration, modification, improper or inadequate maintenance, use of unauthorized replacement parts, or service provided by anyone other than an authorized M2R service center and/or dealer. This warranty does not cover transportation costs for warranty service. Without limiting the above, this warranty is Voided with respect to any product that has been used for rental or commercial purposes or that sustained the following damage:

- Bent or broken frame or swing-arm due to abuse
- Bent or broken wheels due to abuse
- Bent or broken plastic shrouds due to abuse
- Any sign of impact, accident, spin-outs or roll over not caused by the condition for which the warranty coverage is sought.

TO GET SERVICE: Contact your nearest M2R service center and/or dealer. The cost of transportation of the product to and from the service center and/or dealer must be paid by the owner.

M2R obligation under this warranty is strictly and exclusively limited to the repair or replacement of defective parts and M2R does not assume or authorize anyone to assume for them any other obligation. No service center and/or dealer is authorized to modify this warranty.

All implied warranties are limited in duration to the stated warranty period, and are hereby expressly disclaimed in their entirety after the expiration of the stated 6 month warranty period.

CONTENTS

<p>IMPORTANT WARRANTY INFORMATION ————— 04</p> <p>INTRODUCTION ————— 06</p> <p>IMPORTANT SAFETY INFORMATION ————— 07, 08</p> <p>SAFETY INFORMATION FOR PARENTS ————— 09</p> <p>SAFETY LABEL INFORMATION ————— 10</p> <p>COMPONENT LOCATIONS ————— 11 - 12</p> <p>SERIAL NUMBER LOCATIONS ————— 13</p> <p>HANDLE BAR LEVER CONTROL S ————— 13</p> <p>OPERATING CONTROLS ————— 14 - 15</p> <p>BEFORE RIDING ————— 16</p> <p>PROTECTIVE GEAR & APPAREL ————— 16</p> <p>IS THE MOTORCYCLE READY TO RIDE ————— 17</p> <p>PRE-RIDE INSPECTION ————— 17</p> <p>BASIC OPERATION & RIDING ————— 18 - 20</p> <p>BREAK-IN PERIOD ————— 18</p> <p>SAFE RIDE PRECAUTIONS ————— 18</p> <p>ENGINE STARTING PROCEDURE ————— 19</p> <p>FLOODED ENGINE ————— 20</p> <p>STOPPING THE ENGINE ————— 20</p> <p>SHIFTING GEARS ————— 21</p> <p>BRAKING TECHNIQUE ————— 22</p> <p>PARKING & POST RIDE INSPECTION ————— 22</p> <p>MAINTAINING YOUR DIRT BIKE ————— 23</p> <p>IMPORTANT SAFETY PRECAUTIONS ————— 23</p> <p>MAINTENANCE SCHEDULE ————— 24 - 25</p> <p>BASIC MAINTENANCE PRECEDURES ————— 25 - 45</p> <p>FUEL, GASOLINE ————— 25</p> <p>REFUELING & INSPECTION ————— 25</p> <p>ENGINE OIL ————— 26</p> <p>CHECKING & ADDING OIL ————— 26</p> <p>CHANGING OIL & FILTER ————— 27</p> <p>CHANGING AIR FILTER ————— 28</p> <p>THROTTLE SYSTEM ————— 29</p> <p>ENGINE IDLE SPEED ————— 30</p> <p>CLUTCH SYSTEM ————— 31</p> <p>SPARK PLUG ————— 32</p> <p>BRAKING SYSTEM ————— 33 - 35</p> <p>BRAKE LEVER ADJUSTMENT ————— 33</p> <p>BRAKE FLUID CHECK ————— 33</p> <p>ADDING BRAKE FLUID ————— 34</p> <p>BRAKE PADS ————— 35</p> <p>BRAKE SYSTEM BLEEDING ————— 35</p>	<p>SUSPENSION SYSTEM ————— 36 - 38</p> <p>FRONT SUSPENSION INSPECTION ————— 36</p> <p>FRONT SUSPENSION ADJUSTMENT ————— 36 - 37</p> <p>REAR SUSPENSION INSPECTION ————— 37</p> <p>REAR SUSPENSION ADJUSTMENT ————— 37 - 38</p> <p>RIMS, TIRES & SPOKES ————— 39 - 41</p> <p>TIRE AIR PRESSURE ————— 39</p> <p>TIRE INSPECTION ————— 40</p> <p>TIRE AND TUBE REPLACEMENT ————— 40</p> <p>NEW TIRE BREAK-IN PERIOD ————— 41</p> <p>DRIVE CHAIN SYSTEM ————— 41 - 45</p> <p>DRIVE CHAIN INSPECTION ————— 41</p> <p>DRIVE SPROCKET INSPECTION ————— 42</p> <p>CHAIN ROLLER INSPECTION ————— 42</p> <p>CHAIN SLIDER INSPECTION ————— 43</p> <p>CHAIN ADJUSTMENT ————— 44</p> <p>CHAIN LUBRICATION ————— 44</p> <p>CHAIN REMOVAL & REPLACEMENT ————— 45</p> <p>TROUBLESHOOTING ————— 46-50</p> <p>RESOLVING THE UNEXPECTED ————— 51, 52</p> <p>TORQUE SPECIFICATIONS ————— 53 - 55</p> <p>MAINTENANCE RECORDS ————— 56</p> <p>NOTES ————— 60</p>
---------------------------------------------------------------------------------------------------------------------------------------------------------------------------------------------------------------------------------------------------------------------------------------------------------------------------------------------------------------------------------------------------------------------------------------------------------------------------------------------------------------------------------------------------------------------------------------------------------------------------------------------------------------------------------------------------------------------------------------------------------------------------------------------------------------------------------------------------------------------------------------------------------------------------------------------------------------------------------------------------------------------------------------------------------------------------------------------------------------------------------------------------------------------------------------------------------------------------------------------------------------------------------------------------------------------------------------------------------------------------------------------------------------------------------------------------------------------------------------------------------------------------------------------------------------------------------------------------------------------------------------------------------------------------------------	-------------------------------------------------------------------------------------------------------------------------------------------------------------------------------------------------------------------------------------------------------------------------------------------------------------------------------------------------------------------------------------------------------------------------------------------------------------------------------------------------------------------------------------------------------------------------------------------------------------------------------------------------------------------------------------------------------------------------------------------------------------------------------------------------------------------------------------------------------------------------------------------------------------------------------------------------------------------------

INTRODUCTION

Congratulations on choosing your M2R motorcycle.

Your M2R motorcycle was designed as a recreational motorcycle for off-road use only by a single rider. This motorcycle is ideal for riders with basic experience.

Before riding, take plenty of time to get acquainted with your motorcycle and how it works. To protect your investment, we urge you to keep your motorcycle well maintained. In addition to regular maintenance, it is just as important to observe and perform all pre-ride and periodic checks detailed in this manual. We also recommend that you read this manual before you begin riding. In this manual you will find safety information, facts, instructions, helpful tips and illustrations. To make it easy to use, the manual contains a table of contents at the beginning of the manual.

As you read through this manual, you will find information that is preceded by a **NOTICE**. This information is intended to help you avoid damage to your motorcycle and/or property around you. This manual covers basic maintenance procedures. A detailed parts diagram manual is available and it can be purchased separately from M2R. The parts manual will be helpful to those with the mechanical skills and tools required to service their own motorcycle.

Whenever you ride, tread lightly. By staying on established trails and riding in approved areas, you will help protect the environment and keep off-road riding areas open for future use.

If you have any questions or you need any special service or repair, remember that your M2R dealer knows your motorcycle best and will be dedicated to your complete satisfaction. Replacement parts and technical support can be obtained through your M2R dealer. Please be sure to register your motorcycle with M2R and report any address changes so that we may contact you in the future concerning important product information.

You can also visit our website at WWW.MADE2RACE.CO.UK / WWW.FUNBIKES.CO.UK



IMPORTANT SAFETY INFORMATION

Your personal safety, and the safety of those around you, is extremely important. Operating this motorcycle safely is an important responsibility. M2R has provided operating procedures and other information on labels and in this manual to help you make informed decisions about safety. This information will alert you to potential hazards that could harm you or others.

It is understood that it is not practical or possible to warn you about all possible hazards associated with operating and maintaining a motorcycle. You must use your own good judgment.

Safety information will come in a variety of different forms, including:

- ❖ Safety Labels on the Motorcycle.
- ❖ Safety Messages preceded by a safety symbol and one of these signal words:

Below are the definitions of these three words:

 **DANGER** You WILL be KILLED or SERIOUSLY INJURED if you do not follow instructions.

 **WARNING** You CAN be KILLED or SERIOUSLY INJURED if you do not follow instructions.

 **CAUTION** You CAN be INJURED if you do not follow instructions.

- ❖ Safety Headings such as important safety reminders and/or precautions.
- ❖ Safety Section such as motorcycle safety.
- ❖ Instructions how to use the motorcycle safely and correctly.

This entire manual is filled with important safety information - please read it carefully.

IMPORTANT SAFETY INFORMATION

A motorcycle can provide many years of service and pleasure, provided you take responsibility for safety, properly maintain your motorcycle and understand the challenges you may encounter while riding. Listed below are some of the most important safety measures one should take when riding.

⚠ DANGER Never Ride Without a Helmet. The following statement is a proven fact: Helmets significantly reduce the number and severity of head injuries.” Never ride your motorcycle without a helmet. Even a crash at slow speed can result in a fatal head injury if you are not wearing a helmet. M2R strongly recommends wearing helmets that have been certified for safety by helmet testing organizations that are independent from the helmet manufacturer. We also recommend that you wear eye protection, boots, gloves, and other protective gear such as riding pants.

⚠ WARNING Never Carry a Passenger. This motorcycle has been designed for ONE rider only. There are no passenger pegs, footrests, handles or seat room for a passenger. Riding with a passenger can interfere with your ability to operate and/or control the motorcycle and may result in serious injury or death.

⚠ WARNING Ride Off-Road Only. This motorcycle has been designed and manufactured for off-road use only. The motorcycle is not equipped with lights, turn signals, horn and other features required to drive a motorcycle on public roads. The tires are not designed for pavement and will make the motorcycle unstable if it is ridden on pavement. If you have to cross a paved road, dismount and walk the motorcycle across the road.

⚠ WARNING Ride Within Your Limits. Never attempt to ride your motorcycle in a manner that is beyond your skill level. It takes time to learn riding skills. Learn to ride your motorcycle step by step. Start by practicing in safe areas at slow speeds and gradually build your skill level. Instruction from an experienced rider(s) is highly recommended. Remember that alcohol, drug use, fatigue and ignorance can reduce your ability to make good decisions and ride safely.

⚠ WARNING Be Alert for Hazards. The terrain or road in which you ride can present many hazards. Always “scan” the terrain or road ahead of you continually. Watch for un-expected turns, drop-offs, ditches, rocks and other hazards. Always maintain a speed slow enough to allow you enough time to see and react to hazards.

⚠ DANGER Do Not Drink and Ride. Even one drink can impair your ability to ride a motorcycle safely. Each drink afterward will make the impairment worse. Do not drink and ride. Do not let your friend’s drink and ride. Remember, in most states throughout the United States, you can be arrested and charged with Driving Under the Influence (DUI) if you are riding a motorcycle while intoxicated. This applies to off-road motorcycles as well.

IMPORTANT SAFETY INFORMATION FOR PARENTS

As a parent, your child's safety is your first priority. Riding an off-road motorcycle is very fun. However, just like riding a bicycle, bad decisions can result in injury. As a parent, you can greatly prevent accidents by making informed decisions about if, when and how your child will ride. Always supervise your child when he/she is riding.

Before you allow your child to ride, you need to decide if he/she is capable of riding. Riding readiness can vary tremendously from one person to another. Age and size are not being the only factors that help determine one's riding readiness. There are three other factors that you should also consider before deciding if your child is ready to ride.

First, consider the **physical ability** of your child. Riders must be able to hold the motorcycle up, get on, and sit comfortably with both feet on the ground. The rider must also be able to reach all of the controls on the handlebars and work the brakes and clutch. Second, consider your child's **athletic ability**. Your child should be good at riding a bicycle before riding a motorcycle. Determine if your child can judge speeds and distances while riding a bicycle and react with the proper hand and foot actions. Any person who does not have good coordination, balance, and agility should not ride this motorcycle.

Finally, determine your child's level of **mental maturity**. It is imperative that you are honest with yourself when you ask yourself the following questions: Does your child think through problems and come to logical conclusions? Does your child obey your rules when they ride their bicycle? If your child makes bad judgments, takes un-warranted risks and/or does not obey your rules, they should not ride this motorcycle.

If you have decided that your child is ready to ride, please remember the following points and never let your child ride without a helmet. It is up to you (parent) to ensure your child's safety, even if they learn to ride from another experienced adult. Never push your child to try things faster than they are willing or capable. Always supervise your child when they are riding and regularly remind them about safety rules. As a parent it is your responsibility to be sure that the motorcycle is properly maintained and kept in safe operating condition.

Modifying this motorcycle or using parts not manufactured by M2R can make your motorcycle unsafe. Before you consider making any modifications or adding an accessory, please read the following information carefully.

 **WARNING** Improper accessories or modifications can cause a crash in which you can be seriously hurt or killed. Follow all instructions in this owner's manual regarding and accessories.

MRZ strongly recommends that you do not remove any original equipment or modify your motorcycle in any way that may alter the design and/or operation. Such a change could drastically impair the stability, handling, acceleration, and braking capabilities of the motorcycle and cause a crash. We also strongly suggest that you do not make any modifications to the exhaust system, noise control system or emission control components.

SAFETY LABEL INFORMATION

This page will show you where to find the safety labels on your motorcycle. You will find that some labels warn you of potential hazards. Others will provide important safety and maintenance information. Please read them carefully and do not remove them. If your label wears off from riding or becomes hard to read, contact your M2R dealer for a replacement.

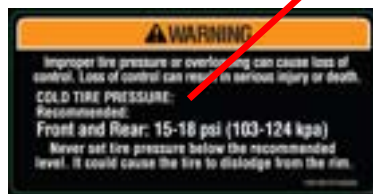

COMPONENT LOCATIONS

When you ride a motorcycle off-road, you need to be able to operate the throttle, clutch, brakes, and other controls without stopping to look at them. Please read this section carefully before you ride your motorcycle. This section of the manual will show the location and operation of all the basic controls of your motorcycle.

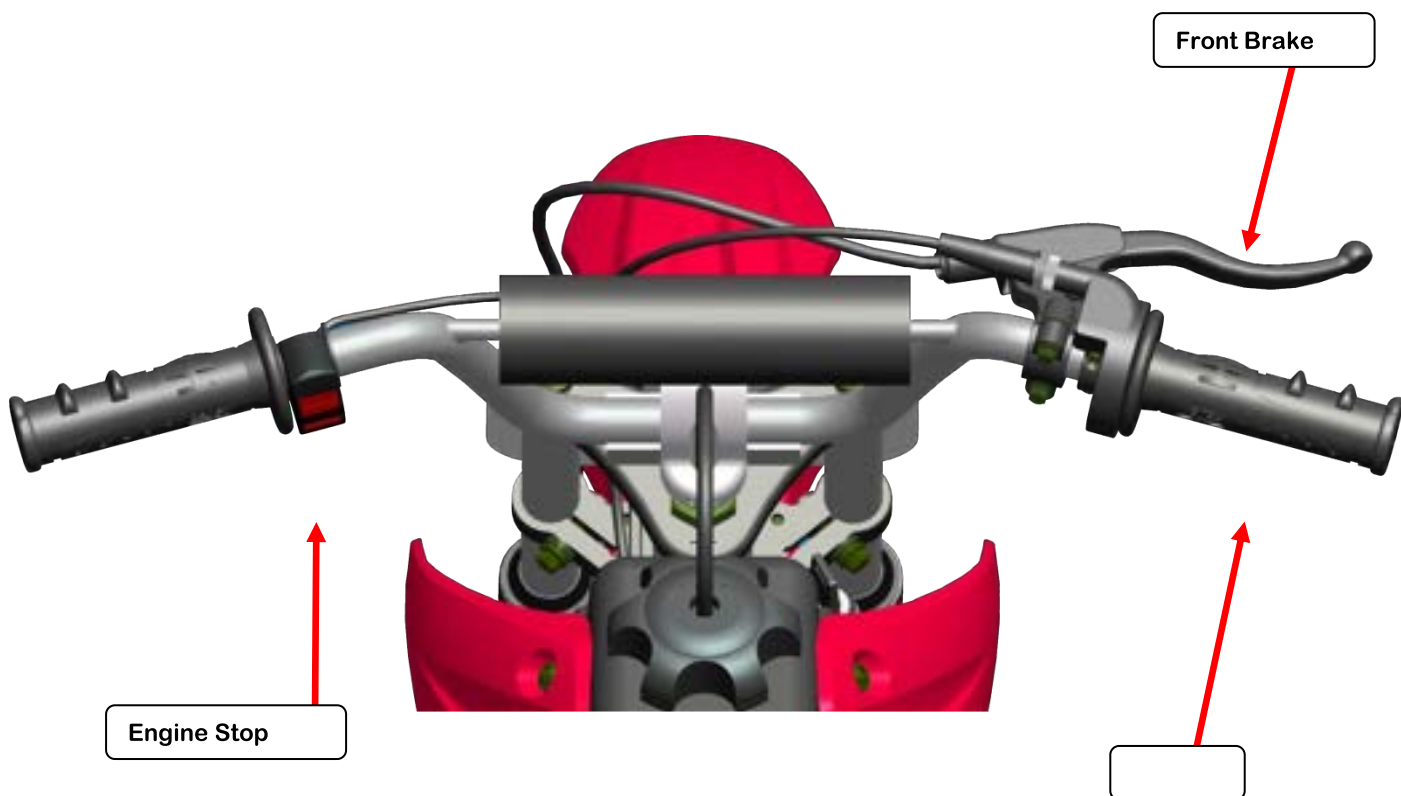

COMPONENT LOCATIONS(OFF-ROAD)

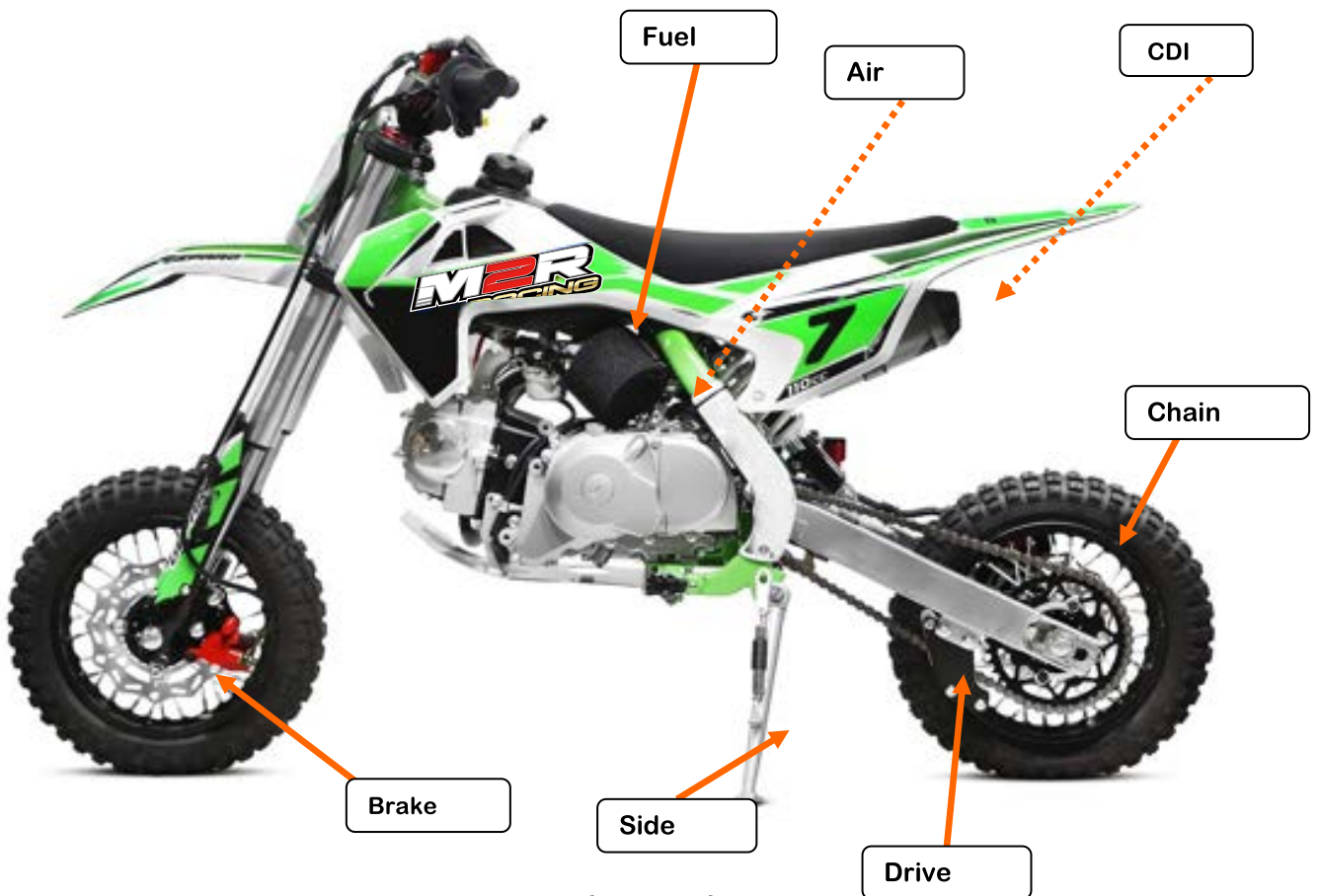
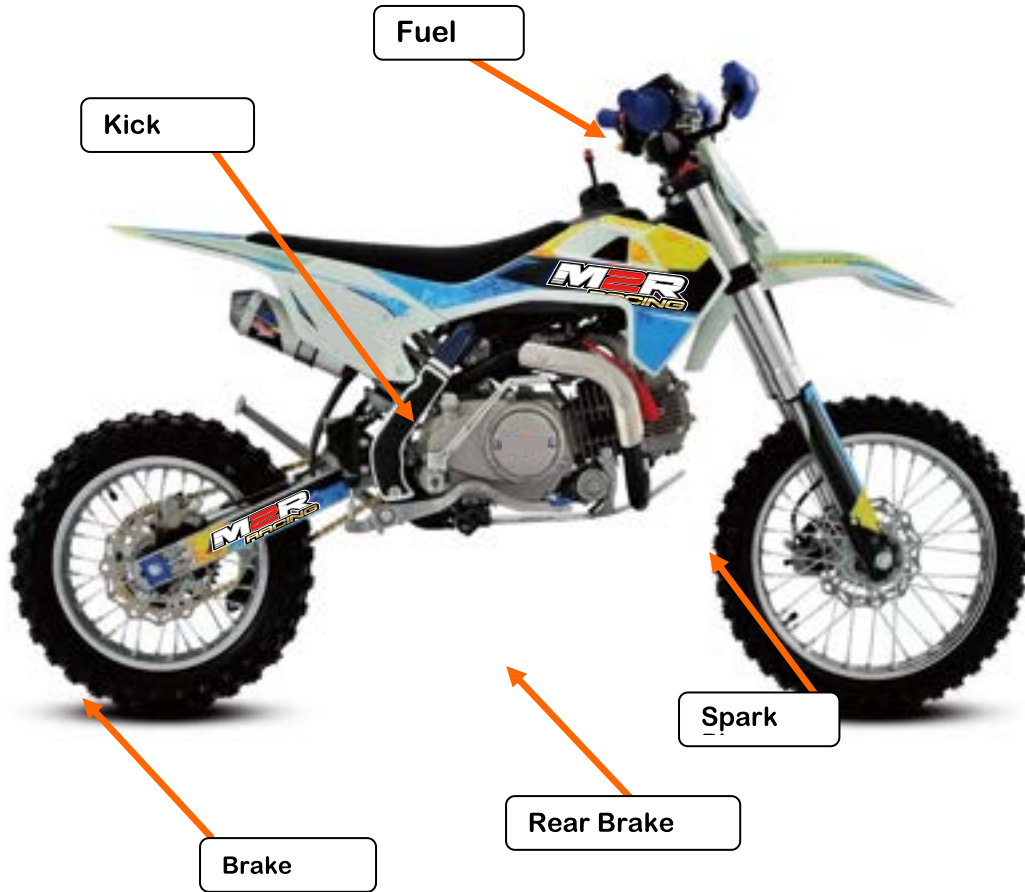

SERIAL NUMBER LOCATIONS

VIN – Chassis Number

The VIN number is located in one of three places on the chassis.

1. Right Side of frame.
2. Left side of frame.
3. Steering head tube.

Write this number in the VIN box on page 3.

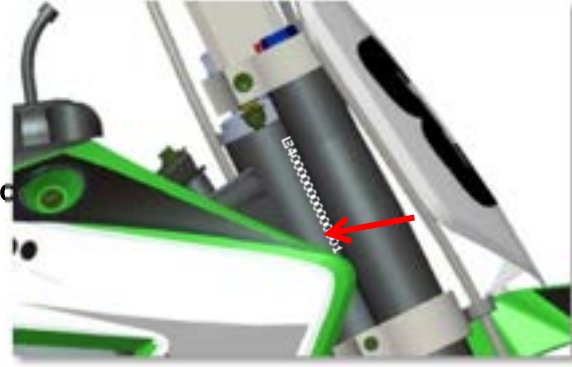

Engine Model & Serial Number

The engine model number and serial number is located on the left side of the engine under the countershaft sprocket.

Write this number in the Engine Number box on page 3.

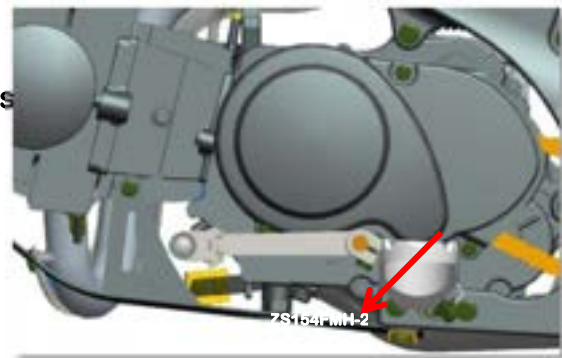

HANDLEBAR LEVER CONTROLS

Hand Brake Lever & Throttle

The hand brake lever and throttle is mounted on the right side of the handlebar.



OPERATING CONTROLS(OFF-ROAD)

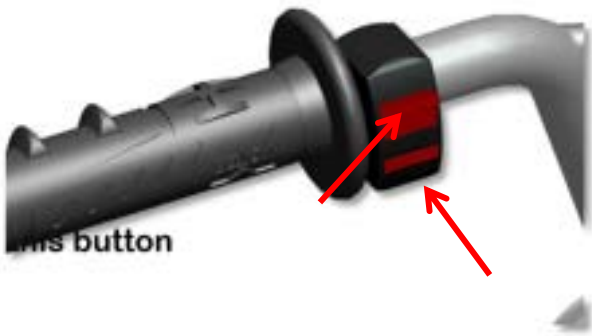

Stop / Run Switch

The stop switch turns off the engine. When is pressed, the ignition circuit is turned off. The run switch lets power go to the electrical

system.

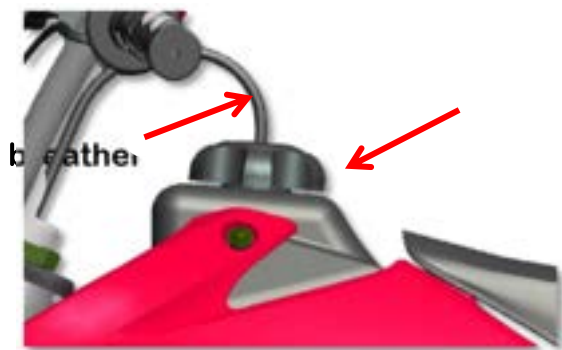

Fuel Fill Cap

To Open: Turn the cap counter-clockwise.
To Close: Turn the cap clockwise, make sure the Tube is installed.

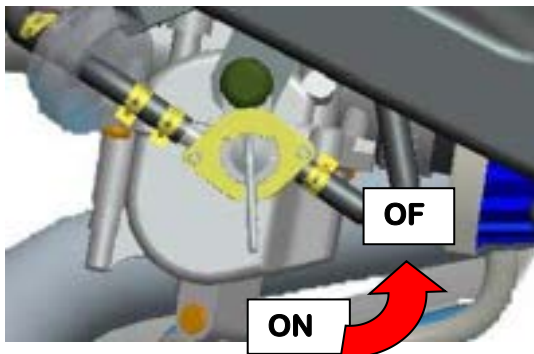

Fuel Tap

- In this position, the fuel tap is closed. No fuel can flow to the carburetor.
In this position, the fuel tap is open. This means fuel can flow to the carburetor. With the lever in this position, the tank will be emptied.

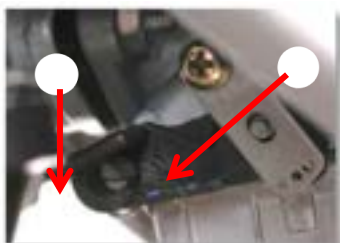

Choke Lever When pulling the choke lever fully toward the top, a cylinder in the carburetor is opened. Through this cylinder, the engine can take in additional fuel. This results in a rich fuel and air mixture, which is needed for a cold start. When pushing down the choke lever, the cylinder is closed again.

OPERATING CONTROLS

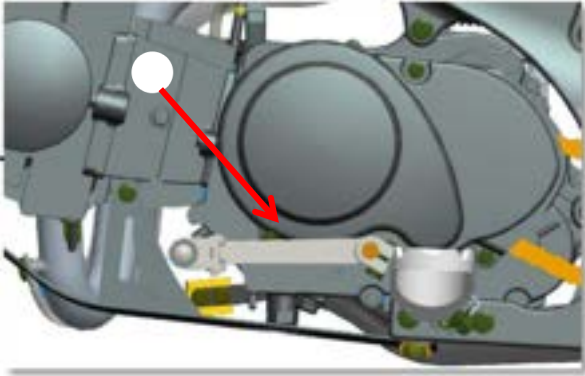

Shift Lever

The shift lever is on the left side of the engine. Its positions are shown in the illustration on page 28.

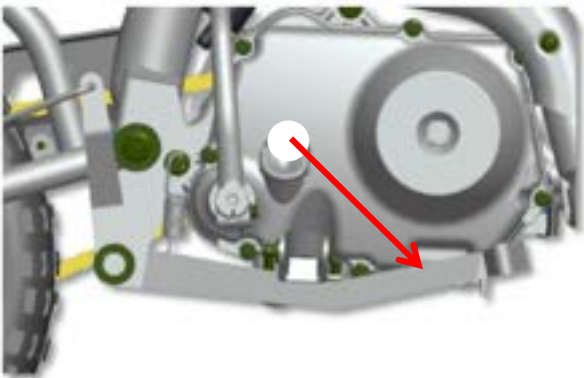

Foot Brake Lever

The brake lever is located on the right side of the engine. Its basic operation is to apply the rear brake to slow or stop the motorcycle.

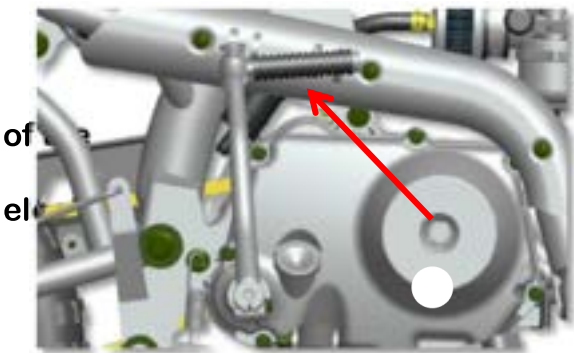

Kick Start Lever

The kick start lever is mounted on the right side of the engine. It is used to start the engine in case the starter system is non-functional.

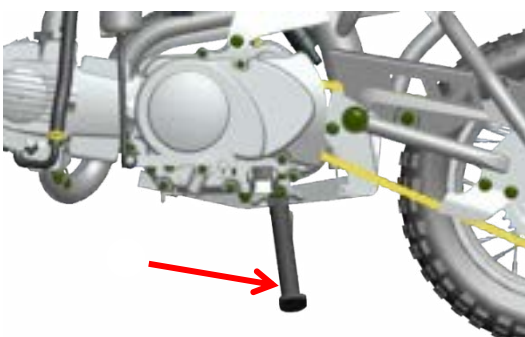

Side Stand

Push the side stand to the ground and tilt the motorcycle to the left. Make sure the bike is on solid ground and the position is secure.

BEFORE RIDING

Before you ride, you must be absolutely sure that you and your motorcycle are ready to ride. To help you get prepared, this section of the manual will discuss how to evaluate your riding readiness and how to perform our recommended pre-ride inspection of your motorcycle. If you are a parent, please be sure you have read the section “Important Safety Information for Parents” on page 9.

Are You Ready to Ride?

Before you ride your motorcycle for the first time, we strongly recommend the following:

1. Completely read this manual.
2. Be sure you have read and understand all the safety messages and labels.
3. You know how to operate all of the motorcycle’s controls.

Before each ride, we strongly recommend that you:

1. Are in good physical and mental condition.
2. Are free of alcohol and other drugs.
3. Are wearing an approved motorcycle helmet with a tight chin strap, eye protection and other protective clothing.

PROTECTIVE GEAR & APPAREL

For your safety, we strongly recommend that you always wear an approved helmet, eye protection, boots, gloves, long pants and a long sleeved jersey, shirt or jacket whenever you ride. Although complete protection is not possible, wearing the proper gear can reduce the chance of and severity of injuries when you ride.

Helmets & Eye Protection – Your helmet is your most important piece of riding gear because it offers the best protection against head injuries. A good helmet will be approved by a testing organization independent of the helmet manufacturer and will have a chin strap that can be tightened securely. Open-face helmets offer some protection, but a full-face helmet offers the most protection. When purchasing a helmet, regardless of style, look for DOT (Department of Transportation) sticker (USA only). If the helmet has been tested by an independent organization such as the Snell Institute, you will usually find their logo on a tag inside the padding of the helmet.

Additional Riding Gear – In addition to your helmet and eye protection, we also recommend:

1. Sturdy off-road motorcycle boots to help protect your feet, ankles and lower legs.
2. Good quality motorcycle gloves to protect your hands.
3. Riding pants with knee and hip pads, a riding jersey with elbow pads and a chest/shoulder protector.

WARNING

NOT WEARING A HELMET INCREASES THE CHANCE OF SERIOUS INJURY OR DEATH IN A CRASH. BE SURE YOU ALWAYS WEAR YOUR HELMET AND OTHER PROTECTIVE APPAREL WHEN YOU RIDE.

IS THE MOTORCYCLE READY TO RIDE?

Before each and every ride you take, it is extremely important that you inspect the motorcycle and make sure any problems you find are corrected. A pre-ride inspection is a must because off-road riding can be very tough on a motorcycle and you do not want to have a breakdown for from help.

WARNING

Improperly maintaining your motorcycle or failing to correct a problem before riding can cause a crash in which you can be seriously hurt or killed. Always preform a pre-ride inspection before any ride and

NOTICE TO PARENTS

If a youngster will be performing any of the following pre-ride inspection procedures, it is your responsibility to provide careful supervision and make sure they are

PRE-RIDE INSPECTION

Check the following items before you get on the motorcycle:

Tires – Use a tire pressure gauge to check the air pressure. Inflate or deflate as needed. Also check for signs of damage or excessive wear.

Spokes & Rims – Make sure all of the spokes are tight. Inspect the rim to be sure it is not bent.

Leaks – Look under the motorcycle for signs of leaking fluids such as engine oil or gasoline.

Engine Oil – Check the level of engine oil and add if needed. For better performance, MRZ recommends using **10W40 or 10W50 ONLY** for off road riding.

Fuel – Check the level of fuel in the gas tank. Add if needed. Be sure the gas cap is tightened securely.

Drive Chain – Inspect the drive chain condition and slack. Adjust and lubricate if needed. Also check the chain guide(s) and roller(s) for wear and replace if and when it is worn. For detailed instructions on drive chain slack adjustment, see the Servicing section of this manual.

Brake Hoses – Inspect the brake hoses for leaks and replace if needed.

Nuts & Bolts – Inspect all accessible nuts and bolts. Tighten then if it is needed.

Spark Plug & Cap – Check the spark plug for looseness. Tighten if needed. Be sure the cap is pushed on the spark plug and it is tight properly.

Check the following items after you get on the motorcycle:

Throttle – Check the throttle free-play and adjust if needed. Rotate the throttle to be sure it moves easily and freely. Make sure that it snaps back to its closed position automatically when you release it in all steering positions.

Brakes – Step on the rear brake lever and squeeze the front brake lever to be sure the brakes are working properly.

Remember, be sure to take care of any problems you find or have your MRZ dealer correct it before you ride.

BASIC OPERATION & RIDING

This section of the manual gives basic information on how to begin riding your motorcycle. In this section we will cover how to start and stop the engine, how to use the throttle and brakes, how to use the clutch and shift gears, and things you need to do when you are finished riding.

Break-In Period

The first 800 km (500 miles) is the most important in the life of your motorcycle. Proper operation during this break-in period will help assure maximum life and performance from your new motorcycle. The following guidelines explain proper break-in procedures.

Maximum Engine Speed Recommendation

The table below shows the maximum engine speed recommendation during the break-in period.

Initial 800 KM (500 MILES)	Below 3000 rpm
Up to 1600 KM (1000 MILES)	Below 5500 rpm
Over 1600 KM (1000 MILES)	Below 8000 rpm

Vary the Engine Speed

Vary the engine speed during the break-in period. This allows the parts to “load” (aiding the mating process) and the “unload” (allowing the parts to cool). Although it is essential to place some stress on the engine components during break-in, you must be careful not to load the engine too much.

SAFE RIDE PRECAUTIONS

Before riding this motorcycle, be sure you have read this entire manual up to this point including the section titled “Important Safety Information (Pg. 7-9)& Before Riding(pg.16)”.

Even if you have ridden other motorcycles in the past, take time to get familiar with the way the motorcycle works and handles. Always practice in a safe area until you have built your skill level to a point at which it is safe to ride.

CAUTION

For your safety, avoid starting or operating the motorcycle in an enclosed area with poor ventilation, such as a garage. The motorcycle’s exhaust gas contains poisonous carbon monoxide which can collect rapidly in an

WARNING

DO NOT ride your motorcycle at night. It is not equipped with lights.

BASIC OPERATION & RIDING

STARTING & STOPPING THE ENGINE

Always follow the proper starting procedure as described below.

STARTING PROCEDURE (ELECTRIC)

Starting When the Engine Is Cold

1. Turn the key switch to the "ON" position.
2. Make sure the transmission is in the neutral position.
3. Turn the fuel tap to the "ON" position.
4. Lift the choke lever up.
5. Press and hold the brake lever on the right side of the handle bar.
6. Open the throttle no more than 1/4 of the way.
7. Press the start "yellow" button until the engine starts.
8. Release the button as soon as the engine starts.
9. After about 1 minute after the engine starts, push the choke lever down.
10. Wait until the engine warms up for approximately 5 minutes. After the 5 minute warm up, you are ready to go.

Starting When the Engine Is Warm

1. Repeat steps 1, 2, 3, 5, 6, 7, and 8 in section "Starting when the engine is cold".

STARTING PROCEDURE (KICK START)

Starting When the Engine Is Cold

1. Turn the key switch to the "ON" position.
2. Make sure the transmission is in the neutral position.
3. Turn the fuel tap to the "ON" position.
4. Lift the choke lever up.
5. Press and hold the brake lever on the right side of the handle bar.
6. Open the throttle no more than 1/4 of the way.
7. Open the kick start lever and from the top of the kick starter stroke, kick through to the bottom with a rapid continuous motion.
8. After about 1 minute after the engine starts, push the choke lever down.(LC - ZS)
9. Wait until the engine warms up for approximately 5 minutes. After the 5 minute warm up, you are ready to go.

Starting When the Engine Is Warm

1. Repeat steps 1, 2, 3, 5, 6, 7, and 8 in section "Starting when the engine is cold"

BASIC OPERATION & RIDING

FLOODED ENGINE

If the engine fails to start after repeated attempts, it may be flooded with excess fuel. Follow the steps below to clear a flooded engine.

1. Press the engine stop switch.
2. Open the throttle completely.
3. Kick start the engine several time. (Kick Start)
4. If necessary remove the spark plug and let it dry.
5. Once the engine starts, open the throttle $\frac{1}{4}$ for a few times.

STOPPING THEENGINE

To stop the engine, shift into neutral and push the engine stop switch on the left side of the handle bar.



CAUTION

DO NOT ride your motorcycle with full load and DO NOT rev up the engine when cold. Since the piston warms up and expands faster than the water cooled cylinder, this might cause engine damage. Always let the engine idle until warm

CAUTION

For your safety, avoid starting or operating the motorcycle in an enclosed area with poor ventilation, such as a garage. The motorcycle's exhaust gas contains poisonous carbon monoxide which can collect rapidly in an

SHIFTING GEARS

This motorcycle has four (4) forward gears.

To start riding, after the engine has been warmed up and the side stand raised:

1. Close the throttle.
2. Raise the shift lever from neutral up to first gear. Once the transmission clicks into gear, the shift lever will return back to the neutral “N” position once you remove your foot.
3. Slowly and gradually open the throttle. When you feel the clutch begin to grab and the motorcycle starts to ease forward, you have reached the “friction zone” of the clutch. Gradually open the throttle more as the motorcycle moves forward.
4. When you attain moderate speed, close the throttle and raise the shift lever until it clicks into second gear. After shifting, re-open the throttle.
5. To continue shifting up to each higher gear, repeat step 4.
6. To shift down to a lower gear, close the throttle depress the shift lever until you feel it click into gear. After shifting, re-apply the throttle smoothly.

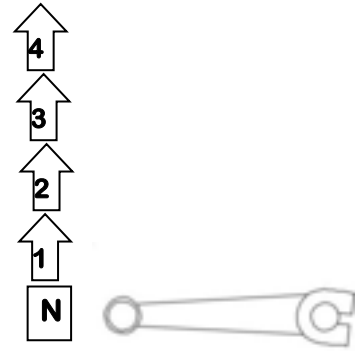

NOTICE

Remember to close the throttle before shifting gears. Improper shifting may damage the engine, transmission, and

Learning when to shift gears will come with riding experience. Up-shift into a higher gear when you hear the engine speed (rpm) get too high. When the engine rpm gets too high in a gear, you will feel the motorcycle stop accelerating. This is another way to know when to up-shift.

Downshift to a lower gear when you feel the engine lugging at a low rpm. Downshifting is usually done when you slow down for a turn or when you stop the motorcycle.

Downshifting into a lower gear can help slow down your motorcycle, especially when going down-hill. However, down shifting when the engine rpm is too high can cause engine damage.

The neutral position of the transmission is located between the first and second gear positions. To shift into neutral, pull the clutch lever in and depress the shift lever as many times as needed to get into first gear. Once you are in first gear, pull up on the shift lever $\frac{1}{2}$ the distance required to up-shift into second gear. You can also shift into neutral from second gear by depressing the shift lever $\frac{1}{2}$ the distance required to downshift into first gear.

To prevent transmission damage, do not coast or tow the motorcycle for long distances with engine off.

WARNING

Never attempt to start the engine in gear. Doing so may cause a crash that could result in serious injury or death.

BRAKING TECHNIQUE

This section will cover basic braking technique for your motorcycle. To slow or stop the motorcycle, squeeze and hold the clutch lever and apply the front brake lever and rear brake pedal firmly and smoothly. If your speed is reduced a significant amount, you may need to downshift to a lower gear. Gradually increase your braking pressure as you feel it is needed. When you come to a stop, put your left foot down first, then the right foot. Do this so that your brake pedal foot remains on the brake pedal until you come to a complete stop. To prevent the engine from stalling, always pull and hold the clutch lever when slowing to a complete stop unless you are in neutral.

For maximum braking, close the throttle and firmly apply both the front and rear brake. On a motorcycle, the front brake accounts for 70% of the total stopping power of the motorcycle. The rear brake only accounts for 30%. This is because of the weight transfer that occurs when you apply the brakes. When you must stop quickly, you must use the front brake together with the rear brake.

Remember that you can apply more brake to the front wheel than you can to the rear wheel before it will lock up and cause a skid. Finding the proper balance between the amount of front and rear brake pressure you use will come with experience. Attempting an abrupt stop with only the rear brake will likely cause a skid.

Applying the brakes too hard or too fast can cause the wheels to lock and cause a skid, reducing your control of the motorcycle. If this happens, release the brake controls and steer straight ahead until you regain control of the motorcycle. Once you have control, reapply the brakes with less force.

Generally, reduce your speed and complete your braking before you begin a turn. Avoid braking or closing the throttle quickly while turning. Either of these actions may cause one or both of the wheels to slip. Any wheel slip will reduce your control over the motorcycle and could cause a crash.

When riding in wet or rainy conditions, or on loose surfaces such as mud or sand, your ability to maneuver and stop the motorcycle will be reduced. All of your actions should be done in a smooth and steady manner under these conditions. Rapid acceleration, braking, or turning can cause you to lose control of the motorcycle. For your safety, exercise extreme caution when riding under wet, rainy, and/or muddy conditions.

When descending a long, steep grade, use engine compression braking by downshifting with intermittent use of both brakes.

PARKING & POST RIDE INSPECTION

Lower the side stand, to support your motorcycle. Press and hold the red stop switch on the left side of the handle bar until your engine stops. If you are through riding for the day, turn the fuel valve to the "OFF" position. Always park the motorcycle on a flat level surface. If you will be storing the motorcycle for a long period of time, turn the fuel valve to the "OFF" position while the engine is still running. Open and close the throttle repeatedly until the engine stops running on its own. Do this to use up any fuel that still remains in the carburetor. This will help you avoid carburetor problems that can occur when your motorcycle is stored for long periods of time with gasoline left in the carburetor.

MAINTAINING YOUR M2R MOTORCYCLE

Keeping your motorcycle in perfect operating condition is absolutely essential to your safety. It is also the best way to protect your investment, get maximum performance, avoid breakdowns, and have more fun. To help keep your motorcycle well maintained, this section includes a maintenance schedule for required servicing and step-by-step instructions on how to perform specific maintenance tasks. In this section you will also find important safety precautions, information on oils, and tips for keeping your M2R motorcycle looking good.

Careful pre-ride inspections and good maintenance are invaluable. To help you properly care for your motorcycle, this section provides you with a maintenance schedule. The service intervals in this section are based on average riding conditions. More frequent service is needed if you subject your motorcycle to severe use, such as competition, or ride in unusually wet and dusty areas. Frequent checks of the air cleaner are very important to help you avoid engine damage.

Remember, proper maintenance is the responsibility of the owner. Be sure to inspect your motorcycle before each ride and follow the maintenance schedule in this section.

WARNING

Improperly maintaining this motorcycle or failing to correct a problem before you ride can cause a crash in which you can be seriously injured or killed. Always follow the inspection and maintenance

NOTICE TO PARENTS

As a parent, it is up to you to make sure the motorcycle is properly maintained and kept in safe operating condition. For youngsters, learning how to take care of a motorcycle and perform basic maintenance can be an important part of their riding experience. However, if you allow a youngster to perform or assist in any maintenance task(s), such as filling the fuel tank with gasoline, you need to provide close supervision

WARNING

Failure to properly follow maintenance instructions and precautions can cause you to be seriously hurt or killed. Always follow the procedures and precautions in this manual.

IMPORTANT SAFETY PRECAUTIONS

Make sure the engine is off before you begin any maintenance or repairs. This will help eliminate the following hazards:

1. **Carbon Monoxide Poisoning From Engine Exhaust** – Be sure you have adequate ventilation whenever you operate the engine.
2. **Burns From Hot Motorcycle Parts** – Let the engine and exhaust system cool off before you touch them.
3. **Injury From Moving Parts** – Do not run the engine unless instructed to do so.

Read all instructions before you begin a procedure. Make sure you have all of the tools and skills required. To help prevent the motorcycle from falling over, park it on a firm, level surface, using the side stand or a maintenance stand to provide support. To reduce the chance of a fire or explosion, be careful when working around gasoline. Use only a non-flammable (high flash point) solvent such as kerosene to clean parts. Keep cigarettes, sparks, and flames away from all fuel-related parts.

MAINTENANCE SCHEDULE

To keep your motorcycle safe and reliable when you ride, regular inspections and service is required. Below you will find a maintenance schedule that describes when components need to be inspected or serviced. The maintenance schedule lists items that can be performed with basic mechanical skills and hand tools. In addition, the maintenance schedule will list items that involve more extensive procedures and could require special training, tools and/or equipment.

Because this motorcycle does not have an odometer, service intervals in the maintenance schedule are expressed in terms of riding days. To avoid missing required maintenance, we suggest that you develop a good way to record the amount of time you spend riding your motorcycle. If you do not feel capable of performing any of the procedures described in this manual or if you need assistance, please contact your nearest M2R dealer. If you decide to do your own maintenance, use only genuine replacement parts that you have purchased from an M2R dealer or parts purchased directly from M2R. This will ensure the best quality and reliability for your motorcycle.

Always perform the pre-ride inspection described on page 24 at each scheduled maintenance interval.

Each item on the maintenance schedule requires some mechanical knowledge. You will find that some items in the table (marked * and **) may require a higher level of mechanical skill and special tools. If you do not feel capable of performing any procedure, please consult your nearest M2R dealer.

* Indicates items that require a moderate to high level of mechanical skill. We recommend service by an M2R dealer if the owner is not mechanically qualified.

** Indicates items and procedures that require special tools.

Note: Service your motorcycle more frequently when you ride in wet or dusty conditions.

Maintenance Procedures: I = Inspect (clean, adjust or replace if needed), C = Clean, A = Adjust, L = Lubricate, R = Replace, T = Tighten

Maintenance period Items	Odometer (km)						
	750	3000	6000	9000	12000	15000	Everyday check before riding
**Re-seating Valve		I	I	I	I	I	
**Spark Plug		I	R	I	R	I	
**Fuel System		I	I	I	I	I	
*Engine Oil	R	R	R	R	R	R	I
*Valve Gap		A	A	A	A	A	
*Idle Speed		A	A	A	A	A	
*Oil Filter		C	C	C	C	C	
*Fuel Filter		R	R	R	R	R	
*Air Cleaner		C	R	C	R	C	
*Drive Chain		IL	IL	IL	IL	IL	
Fuel Line		I	I	I	I	I	
Throttle Operation		I	I	I	I	I	
Brake Shoes/Pad Wear		I	I	I	I	I	
Brake System		I	I	I	I	I	
Clutch		I	I	I	I	I	
Brake Liquid		I	I	I	I	I	
Nuts, Bolts, Fasteners		I	I	I	I	I	
Wheel/Tire		I	I	I	I	I	

BASIC MAINTENANCE PROCEDURES

FUEL (GASOLINE)

Fuel Recommendation –Any unleaded gasoline with an octane rating of 90 or higher.

The engine in your motorcycle has been designed to run on any gasoline with a pump octane rating of 86 or higher. Most service stations will display the octane rating above each pump. Although it is not required, M2R recommends use of gasoline with a 90 octane rating or higher to ensure maximum performance and reliability.

Use of a lower octane gasoline can cause pre-detonation in the engine. When this occurs, you will hear a persistent “pinging” or “spark knock” which, if severe, can cause engine damage. It is however no cause for concern if you hear light pinging while the engine is under hard acceleration, such as climbing up a hill. If pinging occurs under normal load and a steady engine speed, switch brands of gasoline and be sure you are using the proper octane rating. Use of unleaded fuel is recommended because it produces fewer engine deposits and extends the life of the engine and exhaust components.

Never use stale or contaminated gasoline. Never use gasoline that has been mixed with oil. Avoid getting dust, dirt and water into the fuel tank.

INSPECTION & REFUELING

1. Before refueling your motorcycle, check the fuel hoses for leaks, damage, cracks, or deterioration.
2. Replace the fuel hose if you feel it is necessary.
3. Inspect the fuel filter, replace if necessary. (If available)
4. Twist the fuel tank cap counter-clockwise and remove the cap from the tank.
5. Using a funnel, add fuel to the tank until the level reaches about 2 inches from the top of the tank.
6. Twist the fuel cap clockwise until it is securely tight.
7. Be sure that you have the breather tube connected to the gas tank cap.

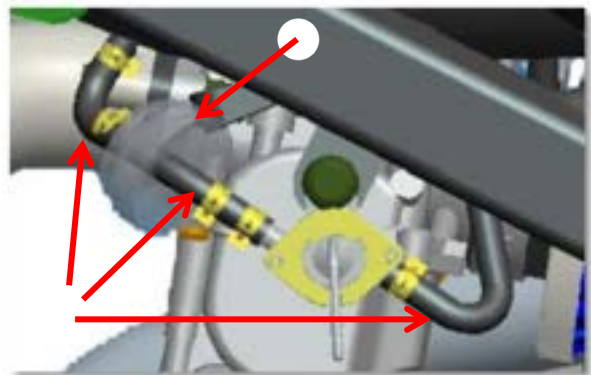
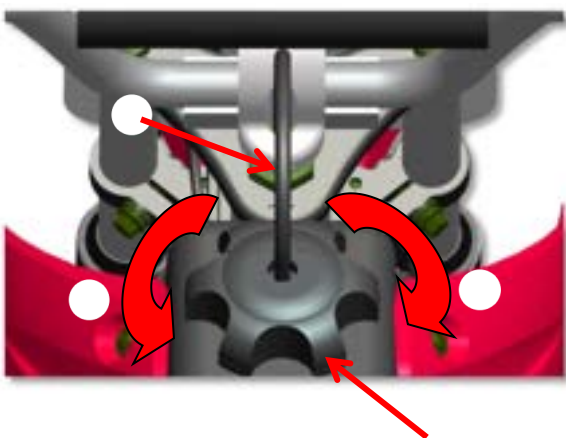

WARNING

Gasoline is highly flammable and explosive. You can be burned or seriously injured when handling gasoline. Always stop the engine. Only handle gasoline

BASIC MAINTENANCE PROCEDURES

ENGINE OIL

Using proper oil, and regularly checking, adding and changing oil will help extend the service life of your engine. Even the best oil wears out and becomes thinner. Changing oil helps get rid of dirt and deposits in the engine. Operating the engine with old or dirty oil may and may damage your engine. Running the engine with not enough oil can cause serious damage to your engine.

The chart below indicates oil for regular air temperatures. Please see the oil/air temperature chart to help you choose the best oil for your climate.

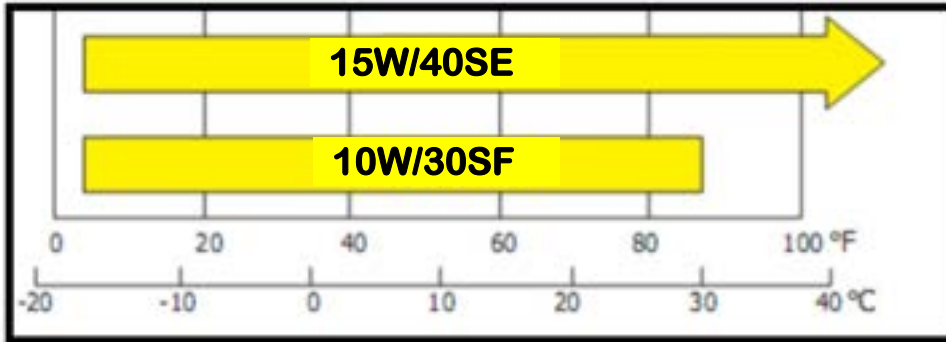

CAUTION

Your motorcycle does not need oil additives. **ONLY** use the recommended oil. **DO NOT** use oil with graphite or molybdenum additives, they may adversely affect the clutch operation. **DO NOT** use motor oils that display the API circular logo that is labeled “energy conserving”, they may

CHECKING & ADDING OIL

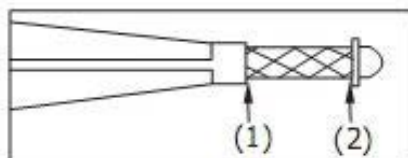

1. Start and run the engine at idle for 3-5 minutes, then stop it.
2. Wait about 2-3 minutes to allow the oil to properly distribute itself in the engine.
3. Stand the motorcycle on a support stand so that it is not leaning to either the right or left.
4. Remove the oil filler cap, wipe it clean, and insert it back in to its place but **DO NOT** screw it back in.
5. Check that the oil level is within the (1) & (2) hash-marks on the dip stick as in Fig. 1
6. If the oil level is at or near the upper mark (1), you do not need to add oil.
7. If the oil level is at or near the lower mark (2), you need to add oil.
8. Add the recommended oil until the upper mark (1), is reached. (**DO NOT OVERFILL**)
9. Repeat steps 1 through 5.
10. Reinstall the dipstick and check for any leaks.

Fig. 1

BASIC MAINTENANCE PROCEDURES

ENGINE OIL Cont.

NOTICE

Allow the engine oil to circulate in the engine for 2 – 3 minutes before riding at start up. This will give enough time for the oil to lubricate all critical engine components. Failure to do so, will cause

NOTICE

Improper disposal of drained fluids is harmful to the environment.

NOTICE

If the oil filter and cap are not installed correctly, it will cause serious engine

NOTICE

Do Not dispose of drained oil in an appropriate manner. Most parts stores or auto shops do take used oil.

CHANGING OIL & OIL FILTER

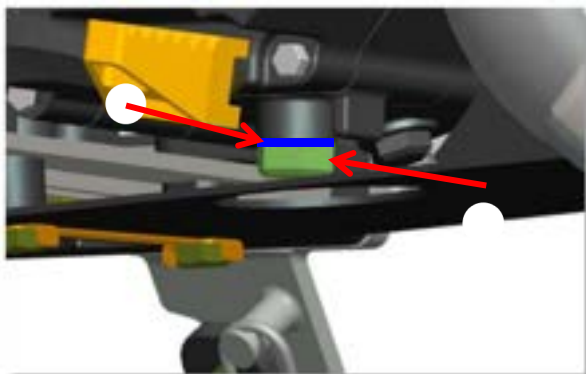

1. Start and run the engine at idle for 3-5 minutes, then stop it.
2. Stand the motorcycle on a straight level surface so that it is not leaning to either the right or left & support it.
3. Remove the oil filler cap. (Pg. 27)
4. Place the oil drain pan under the engine.
5. Remove the oil drain bolt and sealing washer.
6. As the oil is draining out, press and hold the engine stop button and the starter button. The engine will turn but will not start. This will allow all the oil to be drained from the engine. (ONLY FOR 5 SECONDS)
7. After the oil has drained, apply fresh engine oil to the drain bolt threads.
8. Install and tighten the drain bolt with a new sealing washer to 11ft lbs. (15Nm)
9. It is recommended to replace the oil after every 15 hours of riding.
10. Fill the crankcase with the recommended oil only.
11. Install the oil filler cap.
12. Check the oil level by following the steps in “Checking & Adding Oil”.

BASIC MAINTENANCE PROCEDURES

AIR FILTER

Proper air filter maintenance is extremely important for off-road vehicles. A dirty, water-soaked, worn-out air filter will allow dirt, dust, mud or other impurities to pass into the engine. If you are riding in wet and/or muddy areas, you should service the air filter more often. Always replace the air filter with a genuine MZR filter specifically designed for your model or a filter of equal quality.

Failure to maintain the filter can/may cause engine wear or damage, expensive repairs, low engine power, low fuel mileage, carbon build up on valves and foul the spark plug.

CHANGING THE AIR FILTER

1. Loosen the clamp that is holding the air filter on to the carburetor.
2. Once you have loosened the clamp take out the air filter.
3. If the filter has a tear or break in the filter element, it must be replaced.
4. Once the filter is removed, wash it clean with a non-flammable cleaning solvent. Then wash in hot, soapy water, rinse well. Then allow the filter to dry well.
5. When the filter is thoroughly dry, spray the filter with a good quality air filter oil. Saturate the filter with the oil, rubbing it with both hands. Squeeze out any excess.
6. Assemble the filter back in being careful not to tear the filter.
7. Tighten the clamp on the filter.

NOTICE

Improper or lack of proper air filter maintenance can cause poor

NOTICE

Improper installation of the air filter assembly can/may allow dirt to enter the engine and cause rapid wear of the

BASIC MAINTENANCE PROCEDURES

THROTTLE

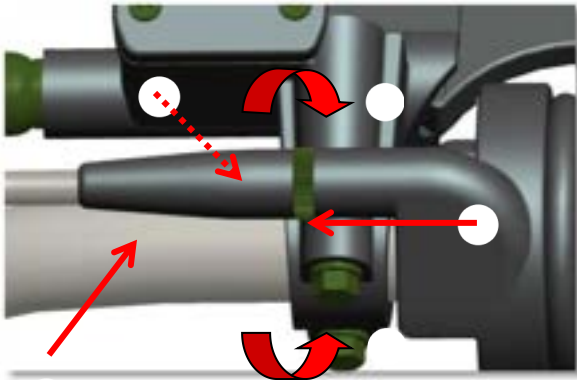

THROTTLE FREEPLAY

- A. Throttle free-play should be 3 – 5 mm (0.10 – 0.20 in)
- B. If your throttle has more play than specified, adjustments need to be made. Follow the steps below:
- C. Minor adjustments are generally made with the upper adjuster.
 1. Pull back the dust cover
 2. Loosen the lock nut
 3. Turn the adjuster
 4. Turning the adjuster in the direction will decrease free-play. Turning the adjuster in the direction will increase free-play.
 5. Operate the throttle to ensure that it is functioning smoothly, and when released, it returns completely from fully open to fully closed in all steering positions.
 6. Inspect the condition of the throttle cable from the throttle down to the carburetor. If the cable is kinked or chafed, it must be replaced.
 7. Lubricate the cable with a commercially available cable lubricant to prevent premature rust and/or corrosion.
 8. Check the cable for tension or stress in all steering positions.

ENGINE IDLE SPEED

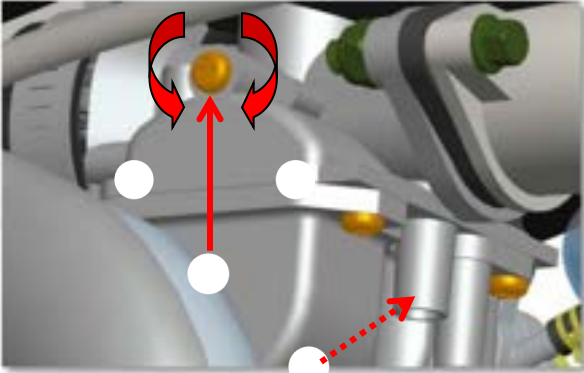

temperature for

ENGINE IDLE SPEED ADJUSTMENT

Remember, idle adjustment is not a real cure for problems in your engines' fuel delivery system.

the idle will not solve or compensate for a fault

in the engine. If you are having trouble, please contact your M2R dealer.

The engine must be at normal operating

an accurate adjustment.

1. If the engine is cold, start it up and let it warm up for 3-5 minutes then shut it off.
2. Connect a tachometer to the engine.
3. Make sure the transmission is in neutral gear.
4. Keep the motorcycle in an upright position.
5. Adjust the idle speed with the stop screw
6. To increase the idle, turn the screw to
7. To decrease the idle, turn the screw to
8. The idle screw might look like and located on different sides of the motorcycle, depending on which model you have.
9. The idle must be at 1500 ± 100 Rpm.
10. **DO NOT** adjust the air/fuel mixture screw. It has been set from the factory. This should only be adjusted by an MRZ dealer. **SEALED FOR THE USA**

BASIC MAINTENANCE PROCEDURES

CLUTCH SYSTEM

In order to ensure the best performance and durability from the clutch, always be sure you have proper clutch free-play. Free-play is needed to ensure that the clutch has room for wear. A clutch with no free-play will begin to slip as the discs wear down. Failure to fix a slipping clutch can cause clutch damage. To check the free-play, simply pull on the clutch lever. The lever should move very easily within the free-play range before you feel the clutch begin to engage. If too much or too little free-play exists, adjustments are needed.

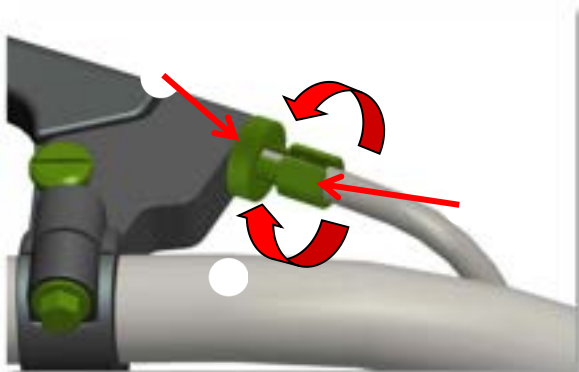

CLUTCH LEVER ADJUSTMENT

The distance between the clutch lever and the grip may be adjusted.

1. Loosen the clutch adjuster lock nut
2. Turn the adjuster clockwise to add free-play and counterclockwise to remove free-play.

A second adjustment may be needed if the clutch is slipping or if the clutch will not engage. Follow the steps below carefully to perform the adjustment. If the clutch is slipping, you will need to decrease the amount of clutch engagement. If you squeeze the clutch lever all the way and the clutch still will not engage, you need to increase the engagement. (Clutch Free-play 10 – 15 mm)



INTEGRAL CABLE ADJUSTMENT

1. Loosen the lock nut
2. Move the integral cable adjuster and lock in to place with the adjuster nut to obtain the specified free-play.
3. Tighten the lock nut and check the adjustment.
4. Start the engine and pull the clutch lever in and shift into gear. Make sure the engine does not stall and the motorcycle does not creep forward.
5. Gradually release the clutch lever and open the throttle. The motorcycle should move smoothly and accelerate gradually.
6. If you cannot get the proper adjustment, see your MRZ dealer or service center.

BASIC MAINTENANCE PROCEDURES

SPARK PLUG

The recommended standard spark plug will work very well in most riding conditions. However, if you plan on riding for extended periods of time at high speed or high engine rpm in hot climates, or plan extended riding in cold climates, a different plug may be recommended.

A fouled (dirty) spark plug can cause your motorcycle to run poorly and lose performance. Follow the steps below to inspect, clean and/or replace the spark plug if needed.

1. Clean any dust and dirt from around the spark plug base.
2. Disconnect the spark plug cap.
3. Remove the spark plug.
4. Using the photos below for reference, examine the plug to determine its cleanliness. If the plug is a normal color, go on to step 6. If the plug is fouled (dirty), go to step 5.
5. Using moderate grit sandpaper (220-400), sand between the center electrode and the side electrode until all carbon and oil deposits are removed. M2R recommends that you use a spark plug cleaner or a new spark plug if the plug is very dirty.
6. Inspect the spark plug electrodes for wear. The center electrode should have square edges. The side electrode should not be eroded at all. The insulator should not be cracked or chipped. Replace the plug if any electrode wear and/or cracks are present.
7. Check the spark plug gap using a spark plug gaper. Gapers can be purchased at your local autoparts store. The spark plug gap should be . 0.5 - 0.8mm. Always check the gap of a new spark plug before you install it.
8. Be sure all dirt has been cleaned from the threads. Install the spark plug by hand. This will prevent stripping and/or cross threading of the threads. Use a 5/8 in socket or wrench to securely tighten the spark plug. Do not over or under tighten the spark plug.

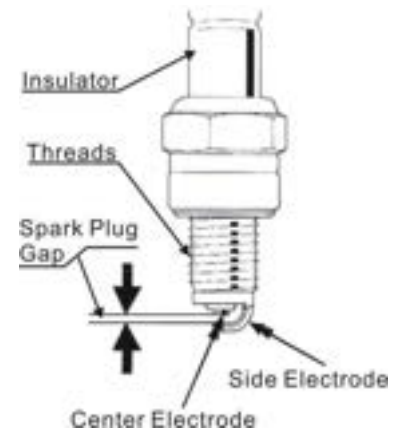

When you inspect the spark plug, generally it will fit into one of the four categories shown above. A normal/clean spark plug will have a light brown center and displays no wear around the electrodes. A spark plug with a bright white center indicates a lean condition in the engine. If your plug looks like this, have your motorcycle serviced by your MRZ dealer immediately. A carbon fouled plug will be completely black with no gloss. An oil fouled plug will appear a dark shiny brown or shiny black as shown above. An oil fouled plug is caused when the engine oil seeps by the piston ring and is burned with the fuel. Oil fouled plugs are not uncommon, however, if your motorcycle is consistently oil fouling spark plugs, have it serviced by your local MRZ dealer immediately.

NOTICE

Using a spark plug with an improper heat range or incorrect reach, can cause engine damage. Using a non-resistor spark plug

NOTICE

An improperly tightened spark plug can damage the engine. If a plug is too loose, a piston may be damaged. If a plug is too tight,

BASIC MAINTENANCE PROCEDURES

BRAKING SYSTEM

Your motorcycle is equipped with hydraulic disc brakes on both the front and rear wheels. Hydraulic brakes require brake fluid for its operation. Both front and rear brakes have a brake fluid reservoir built into the master cylinders. Follow the procedures below to adjust the brake levers to the specified ranges and check fluid levels.

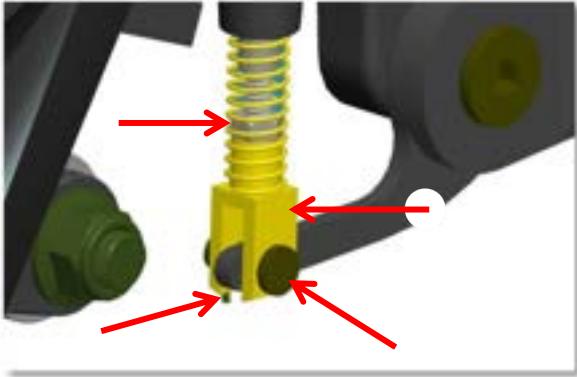

BRAKE LEVER ADJUSTMENT (REAR)

1. Remove the cotter pin .
2. Remove the pin .
3. You can adjust the lever by turning the coupler, it is too tight, raise the return spring (if available) and loosen the lock nut.
4. Once lock nut is loose, adjust the coupler by turning it clockwise or counterclockwise, insert the brake lever back in to the coupler, insert the pin and check the lever height. If it is the desired height, tighten the lock nut, reinstall the pin and then the cotter pin. Make sure the cotter pin is opened so that the pin does not fall out.

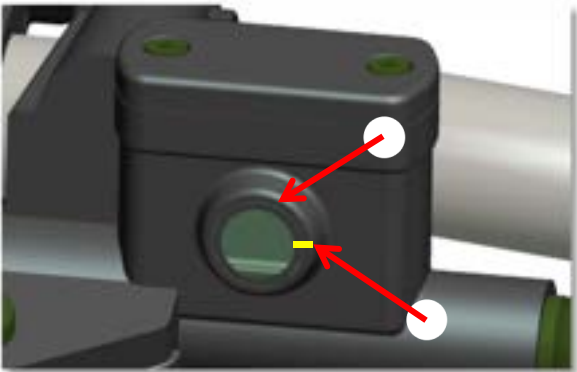

BRAKE FLUID LEVEL CHECK (FRONT)

1. Check the level of the brake fluid by looking in the sightglass periodically with the motorcycle in the upright position.
2. The fluid level should not be lower than half way.
3. If the level is lower than half way, check the brake pads for wear and the system for leaks. (Pg. 47)

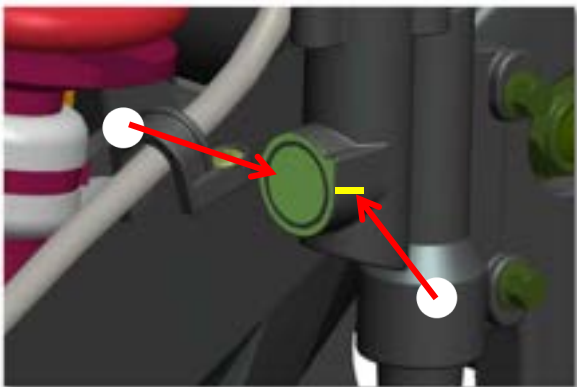

BRAKE FLUID LEVEL CHECK (REAR)

1. Check the level of the brake fluid by looking in the sightglass periodically with the motorcycle in the upright position.
2. The fluid level should not be lower than half way.
3. If the level is lower than half way, check the brake pads for wear and the system for leaks. (Pg. 47)

BASIC MAINTENANCE PROCEDURES

BRAKING SYSTEM Cont.

Hydraulic brakes require brake fluid for its operation. Both front and rear brakes have a brake fluid reservoir built into the master cylinders. Follow the procedures below to check and fill the cylinders with the specified brake fluid. **RECOMMENDED BRAKE FLUID – DOT 4**

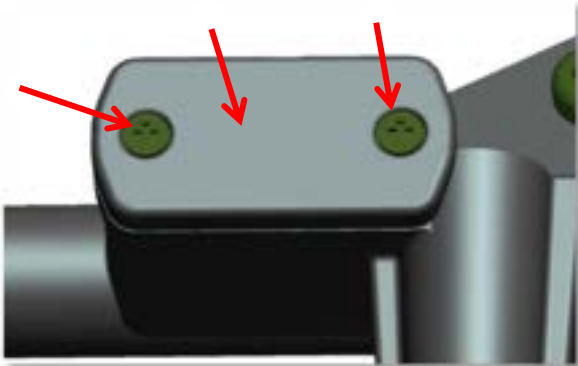

NOTICE

USE ONLY DOT 4 BRAKE

ADDING BRAKE FLUID PROCEDURE

1. Clean all dirt and dust from the master cylinder cap
2. Remove the cap screws with a Phillips head screwdriver.
3. Remove the cap. Be careful not to damage the diaphragm gasket that is seated under the cap.
4. Add the required amount in to the master cylinder. (DO NOT OVERFILL) (Always use fresh fluid sealed bottle)
5. Replace the cap and tighten the screws securely.
6. Squeeze the brake lever to be sure the brakes are working properly.
7. Check the brake hose and brake caliper for leaks.

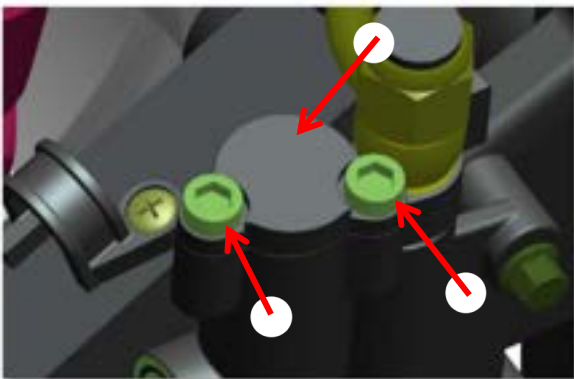

ADDING BRAKE FLUID PROCEDURE

1. Clean all dirt and dust from the master cylinder cap
2. Remove the cap screws with a Phillips head screwdriver.
3. Remove the cap. Be careful not to damage the diaphragm gasket that is seated under the cap.
4. Add the required amount in to the master cylinder. (DO NOT OVERFILL) (Always use fresh fluid sealed bottle)
5. Replace the cap and tighten the screws securely.
6. Press the foot brake lever to be sure the brakes are working properly.
7. Check the brake hose and brake caliper for leaks.

If you are unsure how to re-assemble a part, contact your MRZ dealer for servicing information and/or servicing.

NOTICE

Be very careful not to spill brake fluid on painted surfaces or it will damage the paint. It will also be harmful to some rubber parts. Be careful when you remove the master cylinder cap, make sure the motorcycle is in an upright

BASIC MAINTENANCE PROCEDURES

BRAKING SYSTEM Cont.

Hydraulic disc brake systems use a brake caliper to squeeze the rotors (brake disc) which causes the motorcycle to stop. Inside the brake caliper are brake pads. The brake pads are the part of the brake system that makes contact with the brake rotor. The pads must be checked in accordance with the maintenance schedule for the brake system as described on page(s) 31, 32, 33. Follow the procedure below to check the brake pad wear.

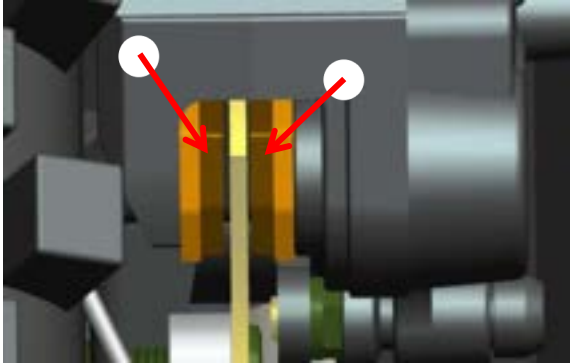

BRAKE PAD WEAR

1. Inspect the brake pads at each maintenance interval.
(more frequently if you do a lot of riding)
2. If the pads are worn down to a thickness of 1 mm, both pads need to be replaced. (Never replace only one pad).
3. If you find that both pads on either front or rear caliper are not wearing down evenly, you may need to replace the brake pads. If one side has worn down more extensive than the other, consult your M2R dealer for a possible bad brake caliper.
4. If you are unsure how to replace the brake pads, please contact your nearest M2R dealer for assistance, or schedule your motorcycle for servicing.

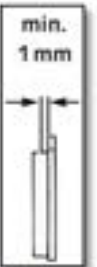

BLEEDING THE BRAKE SYSTEM

Because the brake system utilizes fluid, any air bubbles inside the brake system will cause you to lose braking efficiency. Air generally enters the brake system when the motorcycle sits unused for long periods of time. Air will also enter the system if you have a leaking brake hose, brake caliper or master cylinder. A brake system with air will cause the brake lever and pedal to feel soft and spongy. Use the procedure below to bleed air from both the front and rear brake system.

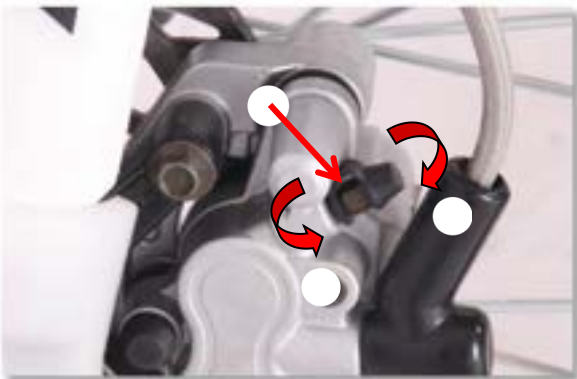

BRAKE BLEEDING PROCEDURE

1. Clean all dust and dirt from the master cylinder and remove the master cylinder cap.
2. Pump the brake lever or pedal slowly and firmly 4-6 times and then hold it.
3. Using an 8mm wrench, loosen the bleeder valve located on the brake caliper. You will see brake fluid, and possibly some air bubbles exit out the bleeder valve.
4. Tighten the bleeder valve and then release the lever or pedal slowly.
5. Repeat steps 1 – 4 until all air bubbles have stopped flowing from the bleeder valve. The lever/pedal should feel hard and firm when you are complete.

NOTICE

USE ONLY DOT 4 BRAKE

BASIC MAINTENANCE PROCEDURES

FRONT SUSPENSION

Loose, worn or damaged suspension components may affect the stability and handling of your motorcycle.

If any of the suspension components seem to be worn or damaged, see your M2R dealer for service and/or inspection. Your M2R dealer is the most qualified to determine whether or not replacement parts or service is required.

Your motorcycle is new. Break it in for about 2 hours with the original settings before attempting adjustments.

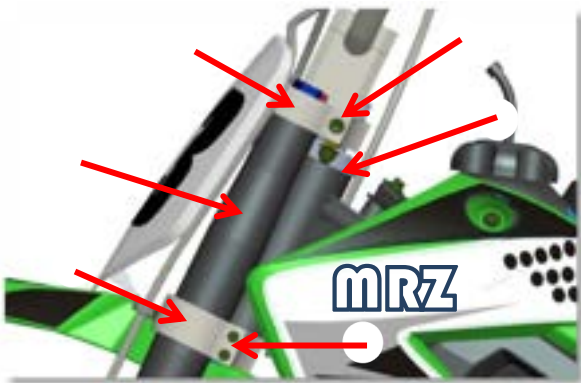

SUSPENSION INSPECTION (FRONT)

1. Check the fork operation by pulling in the front brake lever and holding it to lock the front wheel.
2. Next, pump down on the handle bars several times. The suspension should feel clean and smooth.
3. Check the lower end of the forks (near the wheel) for oil leaks.
4. Inspect the upper and lower triple clamp for tightness.
5. Be sure all the triple clamp bolts are tight.
6. Examine the metal for any cracks, wear or other damage.
7. Be sure there is no free-play in the steering head.

ADJUSTABLE SUSPENSION (FRONT)

1. On the top of the fork, you will find a screw head (or a clicker).
2. It will have the writing S – H, meaning Soft & Hard or the marks { + } or { - }. This is the Compression Adjuster.
3. If you turn the screw toward the “H” { + }, the downward action of the fork will harden. Alternatively, if you turn the screw toward the “S” { - }, the downward action of the fork will soften.
4. To get a good feel for the difference this can make, try turning both screws all the way to the “H” { + } position, then go for a ride. Don't try and set any new records though. Once you have a good feel for the ride, try turning the screws all the way to the “S” { - } position and compare the difference.

NOTICE

Only follow instructions on right if your motorcycle has adjustable

NOTICE

DO NOT TRY TO REPAIR THE FORKS.
IF REPAIR IS NECESSARY, TAKE

NON-ADJUSTABLE SUSPENSION

No Adjustments Necessary

BASIC MAINTENANCE PROCEDURES

FRONT SUSPENSION



ADJUSTABLE SUSPENSION (FRONT)

Over time, the forks suck in air, creating a build-up that will have a bad effect on the performance of the forks.

1. Put a support on the bottom of the bike so that the front tire is off the ground.
2. Turn the air bleeder screw on the top of the fork counter-clockwise to release the air.
3. Make sure you do this with the weight off the front forks and be sure to tighten it back before placing the bike back on the ground.

REAR SUSPENSION

Loose, worn or damaged suspension components may affect the stability and handling of your motorcycle.

If any of the suspension components seem to be worn or damaged, see your M2R dealer for service and/or inspection. Your M2R dealer is the most qualified to determine whether or not replacement parts or service is required.

Your motorcycle is new. Break it in for about 2 hours with the original settings before attempting adjustments.

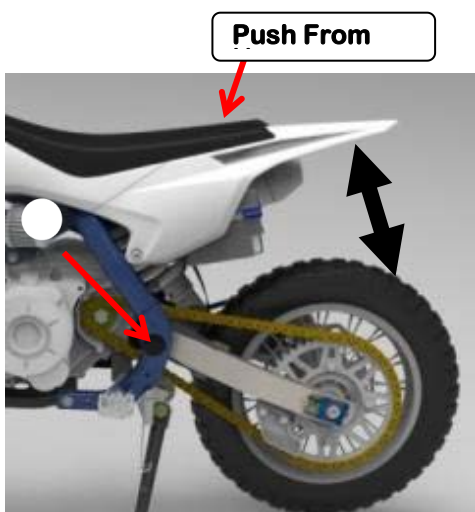

SUSPENSION INSPECTION (REAR)

1. Move the motorcycle by bouncing it up and down to check for smooth suspension action.
2. Check for a broken or damaged spring.
- 3.
4. Check the shock absorber for a bent center shaft or any oil leaks.
5. Check nuts and bolts of shock for tightness.
6. Check the spring adjuster(s) ring(s) for tightness.
7. Check the swing-arm bolts for tightness.
8. Push the rear wheel from side to side feeling for any loose or worn swing-arm bearings. If there is movement, have the motorcycle serviced by your M2R dealer.

NOTICE

DO NOT TRY TO REPAIR THE SHOCK.
IF REPAIR IS NECESSARY, TAKE

BASIC MAINTENANCE PROCEDURES

REAR SUSPENSION Cont.

The rear suspension of your motorcycle has an adjustment point at the bottom of the shock, it comes from the factory set to the softest setting. If you wish to make the rear suspension harder, follow the procedure below. Adjusting the rear shock is not hard, but like the front forks, changes should be made one at a time to gain an accurate understanding of how they affect the bike.

Once you are familiar with the settings on your suspension, you can quickly and easily adjust them to suit different terrain. For example, you make the setting position for when you ride in the sand dunes. But when you are riding on your local motocross track you know to tune it to a different setting.

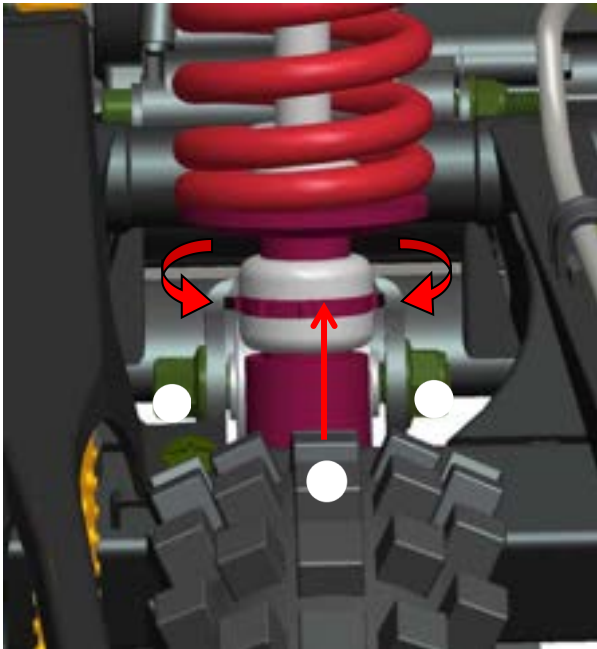

ADJUSTABLE SUSPENSION (REAR)

- A. The rear shock absorber has one adjuster for both compression and rebound .
- B. By turning the adjuster clockwise , this will make the compression harder and rebound slower.
- C. By turning the adjuster counter-clockwise , this will make the compression softer and rebound faster.

NON-ADJUSTABLE SUSPENSION

No Adjustments Necessary

BASIC MAINTENANCE PROCEDURES

RIMS & SPOKES

Maintenance of spoke tension and wheel trueness (roundness) is critical to safe motorcycle operation. During the first 100 miles of riding, spokes will loosen faster due to the initial seating of the parts. Excessively loose spokes will cause the motorcycle to become unstable at high speed and could cause you to lose control. Loose spokes can also cause rim and spoke damage (not covered in the warranty).

It is not necessary to remove the wheels for regular maintenance. However, information on wheel removal is available from MRZ.

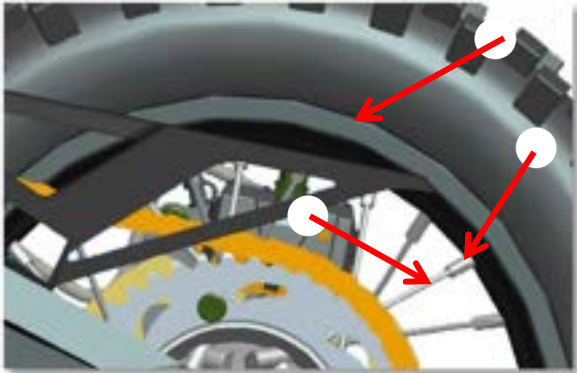

WHEEL INSPECTION (FRONT & REAR)

1. Inspect the wheel rims and spokes for damage. Feel all of the spokes with your fingers to make sure none are loose.
2. Tighten any loose spokes with a small adjustable wrench or spoke wrench from the spoke nut.
3. Elevate each wheel off the ground, one at a time, and spin the wheel slowly. Look for a wobble in the wheel. If a wobble is evident, the wheel is not "true". See your MRZ dealer or local motorcycle shop for inspection.

TIRE AIR PRESSURE

Properly inflated tires will provide you with the best combination of handling, tread life, and riding comfort. Generally speaking, underinflated tires will wear unevenly and adversely affect handling. Underinflated tires are also more likely to fail from being overheated and can cause wheel damage on rocky terrain.

Overinflated tires will cause the motorcycle to ride harshly, are prone to failure from surface hazards and wear unevenly.

Make sure the valve stem caps are secure, if needed, install a new cap. Always check air pressure when your tires are cold. If you check the air pressure when the tires are warm, you will get higher readings. If you let air out of warm tires to match the recommended cold tire pressure, the tires will be underinflated. The correct cold tire pressures are listed below. If you replace the tire, inflate the tire to the following tire pressure amount marked below.

TIRE PRESSURE (off-road)		
Front Tire	70/100-14	15-18Psi (104-
124 kPa)		

TIRE PRESSURE (off-road)		
Front Tire	70/100-17	15-18Psi (104-
124 kPa)		

WARNING

USING TIRES THAT ARE EXCESSIVELY WORN OR IMPROPERLY INFLATED CAN CAUSE A CRASH IN WHICH YOU CAN BE SERIOUSLY INJURED OR KILLED. FOLLOW ALL INSTRUCTIONS IN THIS OWNER'S MANUAL REGARDING TIRE

BASIC MAINTENANCE PROCEDURES

TIRE INSPECTION

A flat tire or tire blowout can be very inconvenient and can even cause you to have an accident. Take the time to inspect your tires and wheels before you ride. For more information about handling a flat tire, refer to the section of this manual titled, Resolving the Unexpected.

- Inspect the tire carefully for bumps or bulges in the sidewall of the tire and inside of the treads. replace any tires that have bumps or bulges in them.
- Look closely for cuts, slits or cracks in the tires. Replace any tire if you can see a fabric or cord showing through.
- Check for rocks or other objects embedded in the tires or tread. Remove any foreign objects. Be sure there are no screws or nails in the tires.
- Measure the tread depth of the tires. Replace all tires before the tread depth gets below 0.12in (3mm) or anytime you notice a reduction in your traction.
- Check the position of both valve stems. A tilted valve stem indicates that the tube is slipping inside of the tire or the tire is slipping on the rim. See your M2R dealer for assistance.

TIRE & TUBE REPLACEMENT

If a tube has been punctured or damaged, it should be replaced immediately. You may repair the tube using a tube patch kit. However, a repaired tube may not have the same reliability as a new one and could fail while riding. For more information on a temporary repair, see the section titled Resolving the Unexpected.

Always use replacement tubes that are the same size as the original. We recommend that you have tubes changed at your local M2R dealer or your local motorcycle shop. Replacing a tube requires removal and installation of the wheel. Anytime you have a tube replaced, perform the tire inspection listed at the top of this page. The tires that came on your motorcycle were designed to provide a good combination of handling, braking, durability and comfort across a broad range of riding conditions.

- Use a replacement tire equivalent in size and type to the original tire.
- Replace the tube anytime you replace a tire. Old tubes are usually stretched and, if installed in a new tire, could fail.
- Have the wheel balanced after a new tire has been installed.
- We recommend that tires be replaced by your M2R dealer or a local motorcycle shop.

TIRE SIZE	
Front Tire	70/100-14
Rear Tire	80/100-12
Type	Bias Ply, Tube

TIRE SIZE	
Front Tire	70/100-17
Rear Tire	90/110-14
Type	Bias Ply, Tube

WARNING

INSTALLING IMPROPER TIRE ON YOUR MOTORCYCLE CAN AFFECT HANDLING AND STABILITY. WHICH, IF SEVERE, CAN CAUSE A CRASH IN WHICH YOU CAN BE SERIOUSLY HURT OR KILLED. ALWAYS USE THE SIZE AND TYPE OF TIRES RECOMMENDED IN THIS

BASIC MAINTENANCE PROCEDURES

BREAKING IN NEW TIRES (ON-ROAD)

New tires need proper break-in to assure maximum performance, just as the engine does. Wear-in the tread surface by gradually increasing your cornering lean angles over the first 160km (100 miles) before attempting maximum performance. Avoid hard acceleration, hard cornering, and hard braking for the first 160 km (100 miles).

WARNING

FAILURE TO PERFORM BREAK-IN OF NEW TIRES COULD CAUSE TIRE SLIP AND LOSS OF CONTROL. USE EXTRA CARE WHEN RIDING ON NEW TIRES. PERFORM PROPER BREAK-IN OF THE TIRES AS

DRIVE CHAIN

The service life of your drive chain will depend on several factors including proper lubrication, adjustment, and riding style. If you are an experienced rider and tend to ride in a more intense manner, or you ride in muddy/dusty areas, you will need to check the drive chain more frequently. Poor maintenance will cause pre-mature wear and/or damage to the drive chain and sprockets.

Before you service your drive chain, be sure you are parked on a level surface and you turn the engine OFF. Be sure the transmission is in neutral. It is not necessary to remove or replace the chain to perform recommended maintenance service.



CHAIN INSPECTION

1. Check the slack in the lower drive chain midway between the sprockets. Push upward on the chain with your finger. The vertical movement should measure between 08 –10 mm.
2. Repeat step 1 along several points of the drive chain. The slack should remain constant through-out. If it is not, some links may be kinked and binding. Lubricating the chain will often stop this.
3. Inspect the drive chain for the following: damaged rollers, loose pins, dry or rusted links, kinked or binding links and excessive wear. Replace the chain, loose pins, or kinks that cannot be freed. Lubricate the drive chain if it appears dry or shows signs of rust. Lubricate any kinked or binding links and work them free.
4. You should replace the drive chain once the rear axle is moved as far back as possible and slack still remains. This indicates that the chain is worn beyond its service limit.
5. Inspect the front and rear sprockets for excessive wear or damage. Refer to the illustration at the top of page 42. If needed, replace any worn or damaged sprockets. See your M2R dealer for assistance.

NOTICE

EXCESSIVE DRIVE CHAIN SLACK MAY ALLOW THE DRIVE CHAIN TO DAMAGE THE ENGINE

NOTICE

ALWAYS USE HIGH QUALITY LUBRICANT FOR THE DRIVE

BASIC MAINTENANCE PROCEDURES

DRIVE CHAIN Cont.

Use the diagram below to determine if the sprockets need to be replaced. Never use a new chain with a damaged or worn sprocket.

NOTICE

THE USE OF A NEW CHAIN ON A WORN SPROCKET WILL CAUSE RAPID CHAIN WEAR.

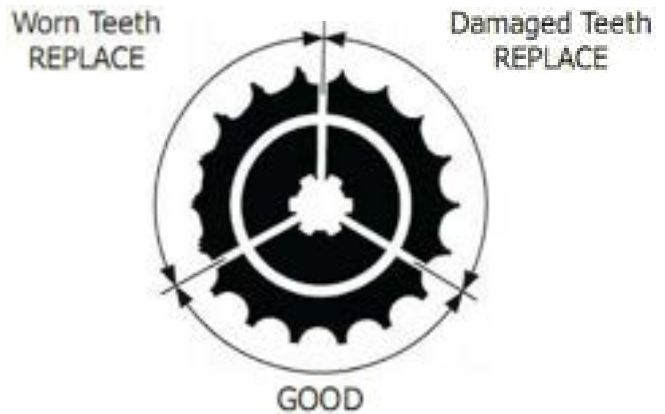

CHAIN ROLLER

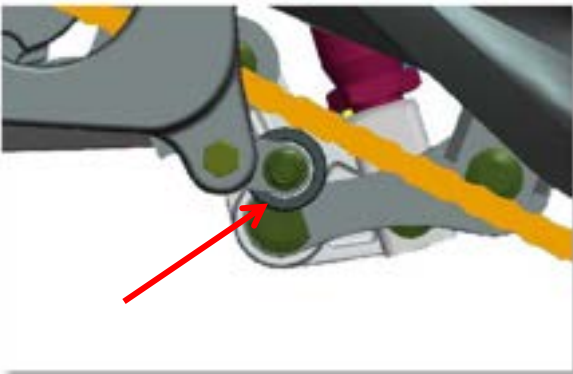

CHAINROLLER INSPECTION

1. Check the lower roller for wear and damage.
2. If the roller is worn or damaged, it must be replaced before your next ride.
3. If the roller has been worn down, then the roller must be replaced.
4. If you cannot or do not know how to replace the roller, take the motorcycle to an M2R dealer for service.

CAUTION

NEVER RIDE YOUR MOTORCYCLE IF THE ROLLERS

NOTICE

ALWAYS USE HIGH QUALITY LUBRICANT FOR THE DRIVE

CHAIN SLIDERS

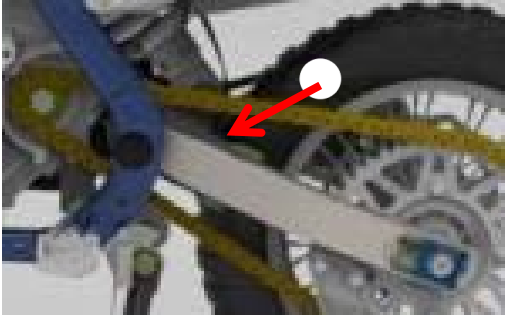

Fig. 2



Fig. 3

CHAINSLIDER INSPECTION

1. Check the slider for wear.
2. If the wear limit has been reached Fig. 3, it must be replaced.

- 1.
2. Check the guide slider for wear Fig 2.
3. Replace the guide slider if it is worn to the bottom of the wear limit. Fig. 3 -

NOTICE

THE SLIDERS MUST BE REPLACED IF WORN DOWN TOO

BASIC MAINTENANCE PROCEDURES

CHAIN ADJUSTMENT

Follow the procedure below to adjust the drive chain slack. Be sure that you are parked on a level surface and the engine is turned OFF.

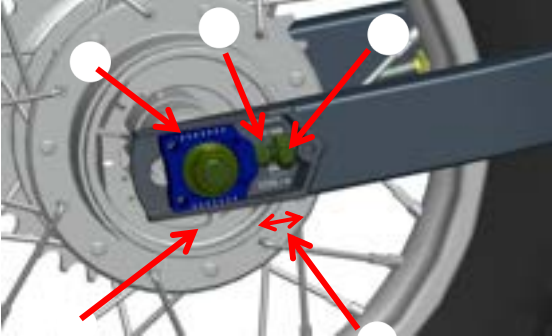

CHAIN ADJUSTMENT

1. Loosen the rear axle nut
2. Loosen the lock nut on both right and left side.
3. Turn the adjusting bolts counter-clockwise to decrease slack in the chain, or clockwise to increase slack.
4. Make sure the gap between the adjusting plate and swing arm are the same on both left and right sides.
5. Tighten the axle nut to 85ft-lbs. (115 Nm)
6. Re-check chain slack and readjust if necessary.



CHAIN LUBRICATION

Commercially prepared chain lubricants may be at most motorcycle shops and should be used motor oil. Chain lube or gear oil (80w or 90w) is recommended. Saturate each joint so that the lubricant space between each surface of the link plates

penetrates the
and rollers.

BASIC MAINTENANCE PROCEDURES

DRIVE CHAIN Cont.

If you have been riding in extremely muddy or dusty conditions, the drive chain should be removed and cleaned before you apply lubricant. Follow the procedure below to remove and clean or replace the drive chain with a new one.

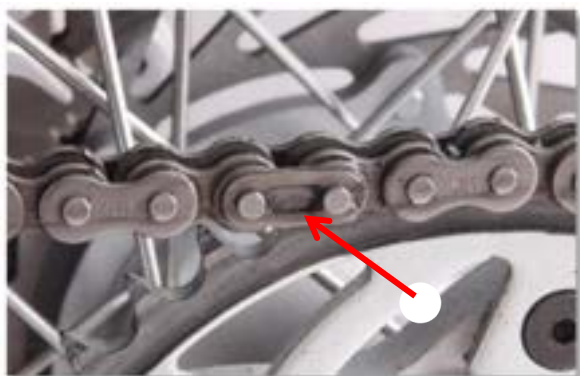

CHAIN REMOVAL, CLEANING &

1. Remove the master link retaining clip with needle nose pliers. Do not bend or twist the clip. Remove the master link and remove the drive chain.
2. Clean the drive chain with a non-flammable solvent such as kerosene - NOT gasoline – and allow it to dry.
3. Inspect the drive chain for possible wear or damage. Replace the drive chain if it has any damaged rollers, loose fitting links, or otherwise appear unserviceable.

4. Inspect the sprockets for wear or damage. M2R recommends that you replace the sprockets when you install a new drive chain.
5. Pass the chain over the sprockets and join the ends of the chain with the master link. For ease of assembly, hold the chain ends against adjacent rear sprocket teeth while inserting the master link. Install the master link retaining clip so that the closed end of the retaining clip will face the direction of forward wheel rotation.
6. Lubricate the chain.

The master link is the most critical element of drive chain security. Master links are reusable, as long as they are in excellent condition. We recommend installing a new master link when you install a new drive chain. You may find it easier to install a new chain by connecting it to the old chain using a master link and pulling the old chain to position the new chain on the sprockets.

APPEARANCE CARE.

To clean the motorcycle you can use any of the following: water, mild neutral detergents, mild spray and wipe cleaner, mild spray and rinse cleaner/degreaser. Avoid products that contain harsh detergents or chemical solvents that can damage the metal, paint and plastic on your motorcycle.

We recommend that you use a garden hose to wash your motorcycle. High pressure washers (like coin operated car washers) can damage certain parts of the motorcycle. If you must use a high pressure washer, avoid spraying the following areas: Wheel hubs, muffler outlet, underneath the seat, engine stop switch, underneath the gas tank, drive chain and carburetor.

NOTICE

HIGH PRESSURE WATER OR AIR CAN DAMAGE CERTAIN PARTS OF THE MOTORCYCLE. NEVER WAS THE MOTORCYCLE WHILE THE ENGINE IS RUNNING. ALWAYS LUBRICATE THE DRIVE CHAIN AFTER YOU ARE FINISHED WASHING AND THE MOTORCYCLE IS DRY.

TROUBLESHOOTING

ENGINE DOES NOT START OR IS HARD TO

1. Examine the Carburetor - Be sure there is fuel flowing into the carburetor.

Is there fuel flowing into the carburetor?

No- Clogged fuel hose/line or clogged fuel filter

- Clogged Fuel Valve
- Clogged fuel tank breather hose
- Sticking or stuck carburetor float

Yes- SEE STEP 2

2. Examine the Spark Plug - Remove the spark plug and inspect. (see page 44)

Is the spark plug in good working condition?

No - Flooded engine and/or carburetor

- Choke valve is closed
- Throttle is stuck open
- Dirty or clogged air filter
- Excessively worn piston rings (replace engine)

Yes - SEE STEP 3

3. Spark Test - Test for ignition spark by removing the spark plug and inserting it into the spark plug cap. Place the open end of the spark plug on a metal part of the engine and kick start the engine. You should see a nice blue spark on the end of the spark plug. A faint spark will not start the engine.

Is there a good spark?

No - Fouled or faulty spark plug

- Broken or shorted spark plug wire or spark plug cap
- Broken or shorted ignition coil
- Faulty ignition CDI Box
- Faulty or shorted magneto assembly
- Broken or shorted engine stop switch
- Loose or corroded wires and/or connectors (always clean bad electrical connections)

Yes - SEE STEP 4

4. Cylinder Compression Test - Perform a simple compression test by kick starting the engine slowly. Be sure you have the spark plug installed. While pushing down on the kick starter slowly, you should feel a very hard firmness that will abruptly soften as the kick start lever moves further down. No hard firmness in the kick start lever means you have poor compression.

Is the compression normal?

No - Valve stuck open/seized or improper valve timing (see your M2R dealer)

- Worn cylinder wall and/or piston rings (replace engine)
- Leaking or damaged cylinder head gasket (see your M2R dealer)

Yes - SEE STEP 5

5. Engine Start Condition- Start the engine by using the normal starting procedure (see page 26)

Does the engine start but then stop quickly afterward?

Yes- Improper choke operation

- Dirty or improperly adjusted carburetor (Contact your M2R Dealer)
- Intake manifold/pipe leak
- Improper ignition timing (see your M2R Dealer)
- Dirty or contaminated gasoline

NOTICE

DO NOT TOUCH THE SPARK PLUG OR PLUG CAP WHILE TRYING TO START THE ENGINE. YOU WILL RECEIVE AND ELECTRICAL SHOCK WHICH COULD

TROUBLESHOOTING

ENGINE LACKS POWER

1. Examine the Drive-train - Raise the wheel of the ground and spin by hand.

Does the wheel spin freely?

No - Brake dragging, improperly mounted brake pads

- Worn or damaged wheel bearings

- Bent axle

Yes - SEE STEP 2

2. Check the Tire Pressure - Use a tire pressure gauge to check the tire pressure of each tire (see page 52)

Is the tire pressure correct?

No- Faulty tire valve

- Punctured tire and/or inner tube

Yes - SEE STEP 3

3. Clutch Inspection - Accelerate rapidly through first and second gears.

Does the engine speed/RPM decrease properly when you shift from first gear to second gear?

No- Slipping clutch, adjust (see page 42)

- Worn out clutch discs and/or plates (see page 43)

- Weak clutch springs

- Contaminating additive in the engine oil

Yes- SEE STEP 4

4. Engine Performance Inspection - Accelerate lightly.

Does the engine speed increase?

No- Clogged air filter

- Restricted or clogged fuel line and/or fuel filter

- Clogged muffler/spark plug

- Choke valve is closed

- Clogged fuel tank breather hose

Yes- SEE STEP 5

5. Spark Plug inspection - Remove the spark plug and inspect (see page 44)

Is the spark plug in good working condition?

No- Spark plug is not serviced frequently enough

- Incorrect spark plug heat range (see page 44)

- Incorrect spark plug gap

Yes- SEE STEP 6

6. Engine Oil Inspection - Check the oil level and the condition of the oil

Is the engine oil level correct and in clean condition?

No - Oil level too high

- Oil level too low

- Contaminated oil

Yes - SEE STEP 7

7. Cylinder Compression Inspection - Check the cylinder compression.

Is the engine compression normal?

No - Valve stuck open/seized or improper valve timing (see your M2R dealer)

- Worn cylinder wall and/or piston rings (replace engine)

- Leaking or damaged cylinder head gasket (see your M2R dealer)

Yes- SEE STEP 8

TROUBLESHOOTING

ENGINE LACKS POWER Cont.

8. Carburetor Inspection - Disassemble the carburetor and check for clogs

Was the carburetor clogged and dirty?

No- SEE STEP 9

Yes - Carburetor is not serviced frequently enough

- Contaminated fuel

9. Over Heating Inspection - Check the engine for overheating

Is the engine overheating?

No - GO TO STEP 10

Yes- Excessive carbon buildup in the combustion chamber

- Use of poor quality fuel

- Clutch slipping

- Lean fuel mixture or improper octane rating of fuel

10. Engine Condition Inspection - Accelerate rapidly through all gears and ride at high speed.

Does the engine knock?

No- SEE STEP 11

Yes- Worn piston and cylinder (replace engine)

- Wrong type of fuel (octane rating)

- Lean fuel mixture

- Excessive carbon buildup in the combustion chamber

11. Ignition Timing Inspection - See your local M2R dealer or motorcycle repair shop to have the ignition timing and engine lubrication system inspected. Only attempt these procedures if you are qualified and have the proper tools needed.

Is the ignition timing normal? (Timing is non-adjustable)

No- Faulty CDI ignition box

- Faulty ignition pulse generator

Yes - SEE STEP 12

12. Lubrication Inspection - Remove the valve adjuster hole cap on the cylinder head and inspect for lubrication.

Is the valve train lubricated properly?

No- Clogged oil passage (replace engine)

- Dirty and/or contaminated engine oil

Yes - See your M2R dealer to have your motorcycle serviced.

POOR PERFORMANCE AT IDLE & LOW SPEED

1. Intake Manifold Inspection - Check the intake manifold for leaks

Is there a leak in the manifold?

No- SEE STEP 2

Yes - Loose carburetor mounting bolts

- Damaged insulator/spacer

- Damaged intake manifold gasket

- Cracked or broken intake manifold/pipe

TROUBLESHOOTING

POOR PERFORMANCE AT IDLE & LOW SPEED

2. Spark Test - Test for ignition spark by removing the spark plug and inserting it into the spark plug cap. Place the open end of the spark plug on a metal part of the engine and kickstart the engine. You should see a nice blue spark on the end of the spark plug. A faint spark will not start the engine.

Is there a good spark?

No - Fouled or faulty spark plug

- Broken or shorted spark plug wire or spark plug cap

- Broken or shorted ignition coil

- Faulty ignition CDI Box

- Faulty or shorted magneto assembly

- Broken or shorted engine stop switch

- Loose or corroded wires and/or connectors (always clean bad electrical connections)

Yes - SEE STEP 3

3. Carburetor Air Screw Inspection - Check the carburetor air screw. Turn the screw clockwise until you feel it stop. Do not tighten. Back out the screw counter clockwise 1.5 turns.

Is the air screw setting correct?

No - Adjust using the procedure above.

Yes - SEE STEP 4

4. Ignition Timing Inspection - See your local M2R dealer or motorcycle repair shop to have the ignition timing inspected. Only attempt these procedures if you are qualified and have the proper tools needed.

Is the ignition timing normal? (Timing is non-adjustable)

No - Faulty CDI ignition box

- Faulty ignition pulse generator

Yes - See your MRZ dealer to have your motorcycle serviced

NOTICE

DO NOT TOUCH THE SPARK PLUG OR PLUG CAP WHILE TRYING TO START THE ENGINE. YOU WILL RECEIVE AND ELECTRICAL SHOCK WHICH COULD

POOR PERFORMANCE AT HIGH SPEED

1. Examine the Fuel Line - Disconnect the fuel hose at the carburetor.

Is there fuel flowing freely?

No - Clogged fuel hose/line or clogged fuel filter

- Clogged Fuel Valve

- Clogged fuel tank breather hose

Yes - SEE STEP 2

2. Carburetor Inspection - Disassemble the carburetor and check for clogs.

Was the carburetor clogged and dirty?

No - SEE STEP 3

Yes - Carburetor is not serviced frequently enough, contaminated fuel

3. Ignition Timing & Valve train Inspection - See your local M2R dealer or motorcycle repair shop to have the ignition timing inspected. Only attempt these procedures if you are qualified and have the proper tools needed.

Are the ignition timing, valve timing and valve springs normal? (Timing is non-adjustable)

No - Faulty CDI ignition box

- Faulty ignition pulse generator

- Broken valve spring

- Broken or damaged camshaft sprocket

Yes - See your MRZ dealer to have your motorcycle serviced

TROUBLESHOOTING

POOR HANDLING

Steering is heavy

- Steering stem nut too tight
- Damaged steering head bearings
- Check tire pressure

Either wheel has a Wobble

- Excessive wheel bearing play
- Bent Rim
- Improperly installed wheel hub
- Damaged swing-arm
- Bent frame
- Loose or broken spokes
- Old tires with “dry-rot”

The motorcycle pulls to one side

- Front and rear wheels out of alignment
- Faulty shock absorber
- Damaged fork(s)
- Bent Swing-arm
- Damaged axel
- Damaged frame
- Damaged upper or lower triple clamp

RESOLVING THE UNEXPECTED

GENERAL GUIDELINES

If you encounter trouble during a ride, the first thing you should do is stop as soon as it is safely possible. Do not continue to ride if you have a flat tire, if you hear an unusual noise, or if your motorcycle just does not feel right. If you continue to ride, you will cause more damage the motorcycle and endanger your own safety.

After you stop, take time to carefully look over your motorcycle and identify the problem. Always consider all of your options before you make a decision. Sometimes a problem can be relatively minor and can be permanently repaired on the trail provided you have the tools, supplies and skills needed to do so. In addition, you may be able to make a temporary repair and ride slowly back to your base where you can get further help and/or supplies.

When a problem appears to be more serious; or you do not have the tools, supplies and skills needed to make a repair, you will need to choose a safe way to get yourself and the motorcycle back to your base. If you are close enough, you can often push the motorcycle back.

Whatever the problem may be, always follow the instructions below:

1. Always put safety first.
2. If the problem is minor and you have the tools, supplies and skills needed to make a temporary repair, be sure to make permanent repairs as soon as possible.
3. Do not continue riding if you are hurt or if your motorcycle is not in safe riding condition.

Recommendations for specific problems follow.

IF THE ENGINE QUILTS or WILL NOT START

If the engine was not making unusual noises before it quit running, and it feels normal when you operate the kickstarter, you can probably rule out a major mechanical problem.

First, check the fuel system:

1. Make sure you have fuel in the gas tank and the fuel valve is set to the “ON” position.
2. Check the fuel tank cap breather hose to be sure it is not pinched or clogged.
3. Turn the fuel valve to the “OFF” position. Disconnect the fuel line from the carburetor and momentarily turn the fuel valve to “ON”. If fuel does not flow out, there is an obstruction in the fuel tank, fuel filter, or in the fuel line.

If the fuel system appears to be okay, check the ignition system.

1. Check the spark plug cap. Be sure that it is not loose or disconnected.
2. Disconnect the spark plug cap and remove the spark plug. Connect the spark plug to the plug cap and place the threaded end of the spark plug on a metal part of the engine.
3. Kick the kickstarter while you watch the spark plug. If it sparks, the ignition system is probably working. If there is no spark, replace the spark plug with a new one. If there is still no spark, there is a problem with the ignition system.

If you cannot identify or correct a problem, you will have to push your motorcycle back to your base or get some help.

RESOLVING THE UNEXPECTED

IF YOU HAVE A FLAT TIRE

How you handle a flat tire on the trail will depend on the severity of the damage to the tire and/or the inner tube and what tools and supplies you keep with you. If you have a slow leak or a minor puncture, there are two ways you can try to make a temporary repair:

1. Use an aerosol tire sealer to seal the puncture and inflate the tube. You can do this without removing the wheel.
2. Use a tube repair kit to patch the hole in the inner tube. This requires removal of the wheel and tire.

If the leak is more severe, or a temporary repair does not hold up, you will need to replace the inner tube.

If the tire is also severely damaged, you will need to replace the tire as well.

If you cannot repair the flat tire on the trail, you will need to push the motorcycle back to your base or send for help. Do not ride on a flat tire. The motorcycle will be hard to handle, and if the tire comes off the rim, it can lock up the wheel and cause you to crash.

IF YOU CRASH

Personal safety is the first priority after an accident. If you or anyone else has been injured, take plenty of time to assess the severity of the injuries and determine if it is safe to continue riding. If you cannot ride safely, send someone for help. Do not ride if you will risk further injury or if your motorcycle has been damaged too severely.

If you decide you are capable of riding safely, carefully inspect the motorcycle for damage. Check the tightness of critical nuts and bolts such as the handle bars, control levers, brakes and wheels. If there is minor damage, or you are not sure about possible damage but decide to ride back to your base, ride slowly and cautiously.

Sometimes crash damage is hidden or not immediately apparent. Once you get home, go over your motorcycle thoroughly and fix any problems that you find. Also, be sure to have your M2R dealer inspect the frame and suspension after a serious crash.

IF A COMPONENT FAILS

The drive chain, master link, control cables, brake controls, and other components can be damaged if you ride in dense brush or over rocky terrain. As mentioned earlier, making the repair on the trail will depend on the severity of the damage, tools, supplies, and skills that you have.

1. If the drive chain comes off because the master link clip has been knocked off, you may be able to repair the chain with a new master link. However, if the chain is broken or causes damage when it comes off, you may not be able to make a trailside repair.
2. If any component of the front braking system is damaged, you may be able to ride back to your base carefully using the rear brake for slowing and stopping. Likewise, if a component of the rear braking system fails, you can use the front brake for slowing and stopping.
3. If you damage the throttle cable or some other critical component, the motorcycle may be unsafe to ride. Carefully assess the damage and make any repairs that you can. But if you have any doubts, it is best to be conservative and safe.

TORQUE SPECIFICATIONS

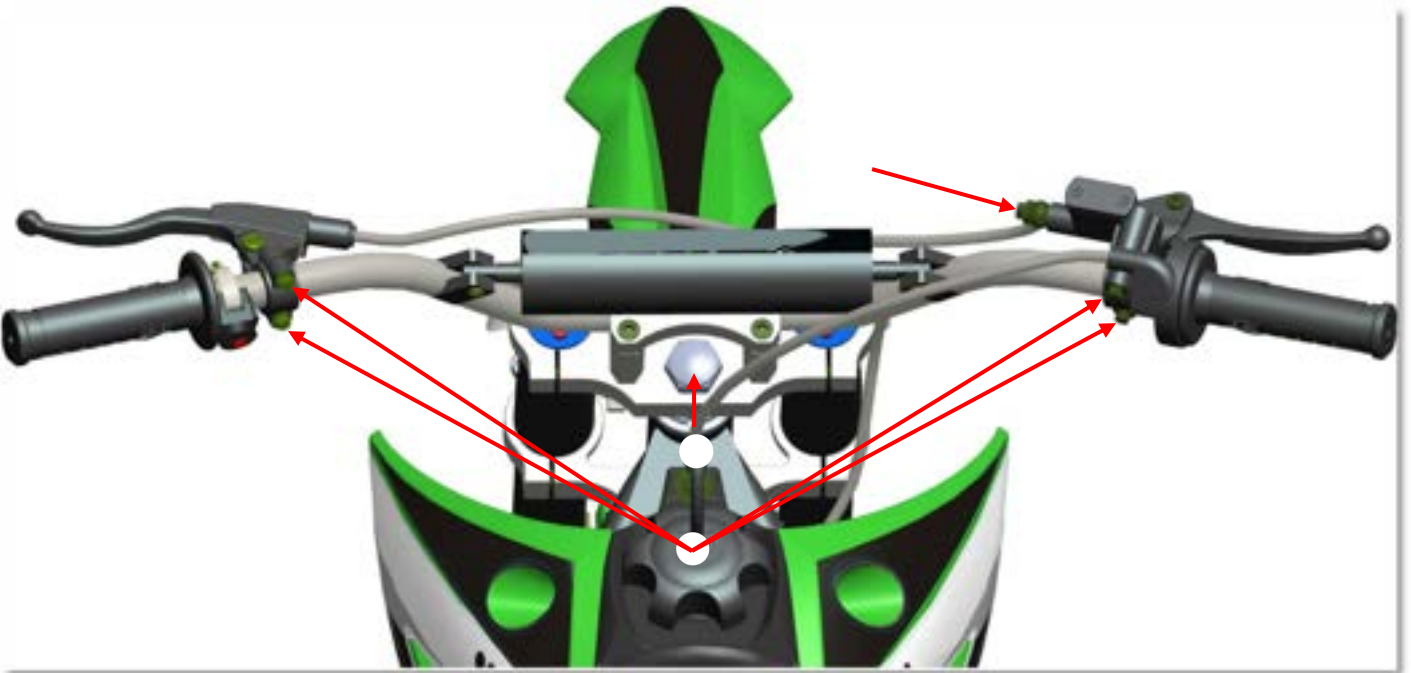

Name		Torque		Notes
		N•m	ft•lb s	
A	Bracket bolts	4.5	3.3	4
B	Steering stem top nut	10.8	8	1
C	Brake hose bolt	32.4	24	

2. Apply loctite 243 liquid to threads
3. Apply grease to bolt, NOT threads.

1. Apply oil to threads.

MAINTENANCE SCHEDULE RECORD

<p>Odometer or Hour Reading</p> <p style="text-align: center;">00,000 km</p> <p>hr. _____</p> <p>Dealer Stamp</p> <p>Date _____</p> <p>Signature _____</p>	<p>Odometer or Hour Reading</p> <p style="text-align: center;"> km</p> <p>hr. _____</p> <p>Dealer Stamp</p> <p>Date _____</p> <p>Signature _____</p>	<p>Odometer or Hour Reading</p> <p style="text-align: center;"> km</p> <p>hr. _____</p> <p>Dealer Stamp</p> <p>Date _____</p> <p>Signature _____</p>
-------------------------------------------------------------------------------------------------------------------------------------------------------------------------------	------------------------------------------------------------------------------------------------------------------------------------------------------------------------------------	------------------------------------------------------------------------------------------------------------------------------------------------------------------------------------

<p>Odometer or Hour Reading</p> <p style="text-align: center;">km</p> <p>hr. _____</p> <p>Dealer Stamp</p> <p>Date _____</p> <p>Signature _____</p>	<p>Odometer or Hour Reading</p> <p style="text-align: center;">km</p> <p>hr. _____</p> <p>Dealer Stamp</p> <p>Date _____</p> <p>Signature _____</p>	<p>Odometer or Hour Reading</p> <p style="text-align: center;">km</p> <p>hr. _____</p> <p>Dealer Stamp</p> <p>Date _____</p> <p>Signature _____</p>
-------------------------------------------------------------------------------------------------------------------------------------------------------------------	-------------------------------------------------------------------------------------------------------------------------------------------------------------------	-------------------------------------------------------------------------------------------------------------------------------------------------------------------

<p>Odometer or Hour Reading</p> <p style="text-align: center;"> km</p> <p>hr. _____</p> <p>Dealer Stamp</p> <p>Date _____</p> <p>Signature _____</p>	<p>Odometer or Hour Reading</p> <p style="text-align: center;">km</p> <p>hr. _____</p> <p>Dealer Stamp</p> <p>Date _____</p> <p>Signature _____</p>	<p>Odometer or Hour Reading</p> <p style="text-align: center;">km</p> <p>hr. _____</p> <p>Dealer Stamp</p> <p>Date _____</p> <p>Signature _____</p>
------------------------------------------------------------------------------------------------------------------------------------------------------------------------------------	-------------------------------------------------------------------------------------------------------------------------------------------------------------------	-------------------------------------------------------------------------------------------------------------------------------------------------------------------

NOTICE
THE FIRST OIL CHANGE MUST BE DONE BEFORE THE

1. Warranty

MRZ USA, Inc.– EMISSION CONTROL SYSTEM WARRANTY

YOUR WARRANTY RIGHTS AND OBLIGATIONS

The emission control system warranty period for this vehicle begins on the date the vehicle is delivered to the ultimate purchaser and each subsequent purchaser other than an authorized dealer, or the date it is first used as a demonstrator, lease, or company vehicle, whichever comes first and continues for **5,000 km or 30 months**, whichever comes first, provided there has been no abuse, neglect or improper maintenance of your vehicle. Where a warrantable condition exists, the dealer will repair your vehicle at no cost to you, including diagnosis, parts and labor. If an emission-related part on your vehicle is defective, the part will be repaired or replaced by the dealer. This is your emission control defects warranty.

OWNER'S WARRANTY RESPONSIBILITIES

As the vehicle owner, you are responsible for the performance of the required maintenance. You should maintain a record of all maintenance performed on your vehicle and retain all receipts covering maintenance on your vehicle. You may not be denied a warranty claim solely because of your failure to ensure the performance of all scheduled maintenance or lack of maintenance records or receipts. You are responsible for presenting your vehicle to an authorized dealer as soon as a problem exists. The warranty repairs should be completed in a reasonable amount of time, not to exceed 30 days.

As the vehicle owner, you should be aware that you may be denied your warranty coverage if your vehicle or a part has failed due to abuse, neglect, improper maintenance, or unapproved modifications.

WARRANTY COVERAGE

The Importer warrants to the ultimate purchaser and each subsequent purchaser that the new 2019 vehicle, including all parts of its emission-control system, meets two conditions:

- ✓ It is designed, built, and equipped so as it conforms at the time of sale to the ultimate purchaser with the applicable requirements of the United States Environmental Protection Agency; and
- ✓ It is free from defects in material and workmanship that may keep it from meeting these requirements.

Your emission control system warranty covers components whose failure would increase an engine's emission, including electronic controls, fuel injection system, carburetor, the ignition system, catalytic converter, or any other system utilized in this vehicle to control emission if it is originally equipped. Also included may be hoses, connectors and other emission-related assemblies. Replacing or repairing other components (including parts, labor, and other costs) not covered by this emission control system warranty or the standard warranty is the responsibility of the owner.

Coverage of repairs under this warranty applies only when repairs are completed at an authorized dealer or repair facility. The importer will not cover repairs performed outside of an authorized dealer or repair facility, except in an emergency situation. The use of replacement parts not equivalent to the original parts may impair the effectiveness of your vehicle's emission control system. If such a replacement part is used and an authorized dealer determines it is defective or causes a failure of a warranted parts, your claim for repair to bring your vehicle into compliance with applicable standards may be denied.

If an emergency situation exists when a warranted part or a dealer is not reasonably available to the owner, repairs may be performed at any available service establishment, or by the owner, using any replacement parts. The importer shall reimburse the owner for the expenses, diagnostic charges, not to exceed the importer's suggested retail price for all warranted parts replaced and labor charges based on the importer's recommend time allowance for the warranty repair and the geographically appropriate hourly labor rate. The owner may reasonably be required to keep receipts and failed parts in order to receive compensation.

This Emission Control System Warranty is in addition to the standard Limited Warranty.

LIST OF EMISSION RELATED PARTS

Part Name	Part Number	Part Manufacturer
Fuel Tank		Wuyi Jiehong Plastic Products Co., Ltd.
Fuel Tank Cap		Wuyi Jiehong Plastic Products Co., Ltd.
Carburetor Assembly		Fujian Fuding Jingke Carburetor Co., Ltd.
CDI		Chongqing Xianfeng Electronics Co., Ltd.
Spark Plug		Chongqing Zongshen Power Machinery Co., Ltd.
Coil		Chongqing Zongshen Power Machinery Co., Ltd.
Air Cleaner		Taizhou Teng Yang Auto Parts Co., Ltd.
Crankcase Breather Separator		Chongqing Zongshen Power Machinery Co., Ltd.

EXCLUSIONS AND LIMITATIONS

This warranty does not cover the following:

- ★ Failures or malfunctions of the emission control systems caused by abuse, alteration, accident, misuse, the use of leaded gasoline.
- ★ Replacement of expendable maintenance items unless they are original equipment defective in material or workmanship under normal use, and the first required replacement interval for the item has not been reached. Expendable maintenance items include but not limited to spark plugs, filters, coolant, lubricants, gaskets, hoses and belts.
- ★ Replacement of parts and other service and adjustments for required maintenance.
- ★ Any vehicle equipped with an odometer or hour meter where the reading is altered so that actual mileage cannot be readily determined.
- ★ Repairs or replacement as a result of:
 - ◇ Accident
 - ◇ Misuse
 - ◇ Use of replacement parts or accessories not conforming to the original specifications which adversely affect performance
- ★ Physical damage, corrosion, or defects caused by fire, explosions or similar causes beyond the control of the importer
- ★ Failures not caused by a defect in material or workmanship.

Use of the vehicle in any type of competitive racing or related events immediately and completely voids this and all other warranties.

CONTACT

No dealer is authorized to modify this Emission-Related Warranty. If you have any questions regarding your warranty rights and responsibilities, you should contact M2R.

WWW.MADE2RACE.CO.UK
WWW.FUNBIKES.CO.UK

NOTES