

MINI PETROL ATV



OWNER'S MANUAL

Read and understand this entire manual before using!

NOTE: Manual illustrations are for demonstration purposes only.

Illustrations may not reflect exact appearance of actual product.

Specifications subject to change without notice.

OFF ROAD USE ONLY!!!

NEVER OPERATE THIS VEHICLE IF YOU ARE UNDER

AGE 16!!!

INTRODUCTION

Thank you for purchasing this mini ATV. The proper care and maintenance that your vehicle requires is outlined in this manual. Following these instructions will ensure a long trouble-free operating life of this vehicle and your satisfaction with it.

The owner's manual corresponded to the latest state of this vehicle at the time of printing. Slight deviations resulting from continuing development and design can, however, not be completely excluded. All specifications are non-binding, we reserve the right to modify or delete technical specification, parts, design, etc... without prior notice.

SAFETY RIDING WARNINGS

This vehicle is NOT A TOY and ONLY used in closed off areas remote from public road traffic.

Never permit children under age 16 to operate this ATV.

–

WARNING: Riding a mini ATV can be a hazardous activity. Certain conditions may cause the equipment to fail without fault of the manufacturer. Like other vehicles, the Mini ATV can and is intended to move, and it is therefore possible to lose control, fall off and/or get into dangerous situations that no amount of care, instruction or expertise can eliminate. If such things occur you can be seriously injured or die, even when using safety equipment and other precautions. **RIDE AT YOUR OWN RISK AND USE COMMON SENSE.**

This manual contains many warnings and cautions concerning the consequences of failing to maintain, inspect or properly use your mini ATV. Because any incident can result in serious injury or even death, we do not repeat the warning of possible serious injury or death each time such a possibility is mentioned.

APPROPRIATE RIDER USE AND PARENTAL SUPERVISION

This manual contains important safety information and use tips to help you and your child operate and handle the mini ATV. Carefully read the manual in its entirety together with your child before letting your child ride it for first time. The manual also contains important information on servicing the vehicle.

It is your responsibility to review the manual and make sure that all riders understand all warnings, cautions, instructions and safety topics and assure that the riders are able to safely and responsibly use this product and protect your child from injury. We recommend that you periodically review and reinforce the information in this manual with your child, and that you inspect and maintain your children's vehicle to insure their safety. **The recommended rider age of 16 years** is only an estimate, and can be affected by the rider's size, weight or skills. Any rider unable to fit comfortably on the mini ATV should not attempt to ride it.

It is important and necessary to conduct the technical training for your child before first use. To get the training information, please contact the dealer who you purchase the vehicle from. Before your child complete the training, do not let your child use this vehicle.

Children often underestimate or fail to recognize the dangerous situation, you should make it clear to your child that should not, under any circumstances, operate the vehicle without supervision and that your child may only drive at speed that are commensurate with the child's riding ability and other road condition.

A parent's decision to allow his or her child to ride this product should be based on the child's maturity, skill and ability to follow rules.

Keep this product away from small children younger than age 16 and remember that this product is intended for use only by persons who are, at a minimum, completely comfortable and competent while operating the vehicle.

DO NOT EXCEED THE WEIGHT LIMIT OF 65KGS. Rider weight does not necessarily mean a person's size is appropriate to fit or maintain control of the mini ATV

Do not touch the brakes or ENGINE on your mini ATV when in use as they can become very hot.

Refer to the following section on safety for additional warnings.

ACCEPTABLE RIDING PRACTICES AND CONDITIONS

Always check and obey any local laws or regulations which may affect the locations where the Mini ATV may be used.

Ride defensively. Watch out for potential obstacles that could catch your wheel or force you to swerve suddenly or lose control. Be careful to avoid pedestrians, skaters, skateboards, scooters, bikes, children or animals who may enter your path, and respect the rights and property of others.

The mini ATV is meant to be used on private property and on closed courses and not on public streets or sidewalks. Do not ride your mini ATV in any areas where pedestrian or vehicle traffic is present.

Do not activate the speed control on the hand grip unless you are on the MINI ATV and in a safe, outdoor environment suitable for riding.

This product was manufactured for performance and durability but are not impervious to damage. Jumping or other aggressive riding can over-stress and damage any product, including the Mini ATV, and the rider assumes all risks associated with high-stress activity.

Be careful and know your limitations. Risk of injury increases as the degree of riding difficulty increases. The rider assumes all risk associated with aggressive riding activities.

Never carry passengers or allow more than one person at a time to ride the electric mini quad.

Never use near steps or swimming pools.

Never use alcohol or drugs before or while operating

Keep your fingers and other body parts away from the drive chain, steering system, wheels and all other moving components.

Never use headphones or a cell phone when riding.

Never hitch a ride with another vehicle.

Do not ride the min quad in wet or icy weather and never immerse the electric mini quad in water, as the electrical and drive components could be damaged by water or create other possibly unsafe conditions.

Wet, slick, bumpy, uneven or rough surfaces may increase risks of use. Do not drive the electric four wheeler in mud, ice, puddles or water. Avoid excessive speeds that can be associated with downhill rides. Never risk damaging surfaces such as carpet or flooring by use of an electric four wheeler indoors.

Do not ride at night or when visibility is limited.

PROPER RIDING ATTIRE

Always wear proper protective equipment such as an approved safety helmet, elbow pads and kneepads. A helmet may be legally required by local law or regulation in your area.

A long-sleeved shirt, long pants and gloves are recommended. Always wear athletic shoes,

never drive barefooted or in sandals, and keep shoelaces tied and out of the way of the wheels, motor and drive system.

FAILURE TO USE COMMON SENSE AND HEED THE ABOVE WARNINGS INCREASES RISK OF SERIOUS INJURY. USE WITH APPROPRIATE CAUTION AND SERIOUS ATTENTION TO SAFE OPERATION.

WARNING STICKER LOCATION



Sticker A is located on the left front fender.

WARNING

Improper use of ATVs can cause SEVERE INJURY OF DEATH



ALWAYS USE AN APPROVED HELMET AND PROTECTIVE



NEVER USE ON PUBLIC ROADS



NEVER CARRY PASSENGERS



NEVER USE WITH DRUGS OR ALCOHOL

NEVER operate:

- without proper training or instruction
- at speeds too fast for your skills or the conditions on public roads – a collision can occur with another vehicle
- with a passenger – passengers affect balance and steering and increase risk of losing control

Always:

- use proper riding techniques to avoid vehicle overturns on hills and rough terrain and in turns.
- avoid paved surfaces – pavement may seriously affect handling and control.

LOCATE AND READ OWNER'S MANUAL.
FOLLOW ALL INSTRUCTIONS AND WARNINGS.

Sticker B is located on the right front fender



Sticker C is located on the right front fender



Sticker D is located in the front of the fuel tank cap



Sticker E is located on the footrest



BEFORE YOU BEGIN

Remove contents from box. Remove the foam separators that protect the components from damage during shipping. Inspect the contents of the box for scratches in the paint, dents or kinked cables that may occur during shipping. Because the product was 85 percent assembled and packed at the factory, there should not be any problems, even if the box has a few scars or dents.

Estimated Assembly and Set-Up Time

We recommend assembly by an adult with experience in motorbike or bicycle mechanics. Allow up to 30-60 minutes for assembly

Required Tools

Some tools may be supplied; however, we recommend the use of mechanic's grade tools. Use the supplied tools only as a last resort.

The list of tool required is as follows:

- Open end wrench 10mm / 13mm-15mm / 14mm-17mm / 24mm
- Allen wrench 5mm / 6mm / 10mm
- Bicycle style tire pump with pressure gauge

Assembly illustration and instruction

ASSEMBLY REAR WHEEL



- A: Nut M16 / 2pcs
- B: Washer Φ 16.5*30*3 / 2pcs
- C: Rear wheel / 2pcs
- D: Split pin / 2pcs
- E: Rear axle / 1pc

1. Fix the wheel(C) through the axle.
2. Mount the spring washer (B) and then tighten the nut (A) securely with 24mm open end wrench.
3. Install the split pin into the A and E.

ASSEMBLY FRONT SHOCK ABSORBER

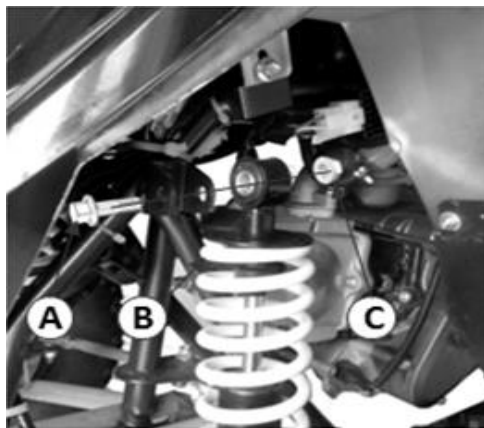

- A: Bolt M10*40 / 2pcs
- B: Front shock / 2pcs
- C: Lock Nut M10 / 2pcs

1. Uplift the frame to align the shock (B) mounting hole to the shackle joint hole.
2. Fix the bolt (A) through the shock mounting hole and shackle joint and tighten the nut (C) securely with 13mm -15mm and 14mm -17mm open end wrench

ASSEMBLY FRONT WHEEL

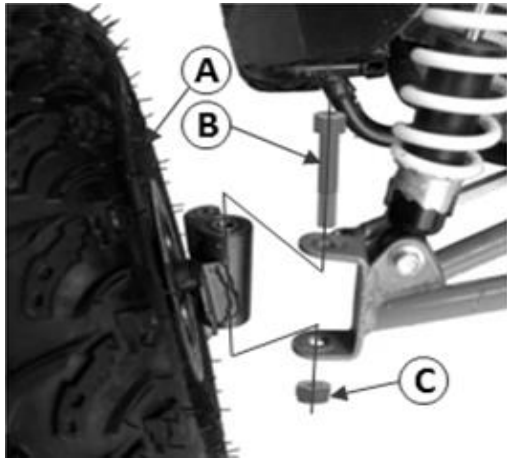

A: Wheel suspension L&R

B: Bolt M10*85*1.5 / 2pcs

C: Nut M10 / 2pcs

1. Put the front wheel suspension (A) into the front swing arm joint, align the bearing hole to the joint upper and bottom hole.
2. Mount the bolt (B) through the hole and twist the nut (C), tighten it securely with 14mm - 17mm open end wrench and 10mm allen wrench.

ASSEMBLY TIE ROD

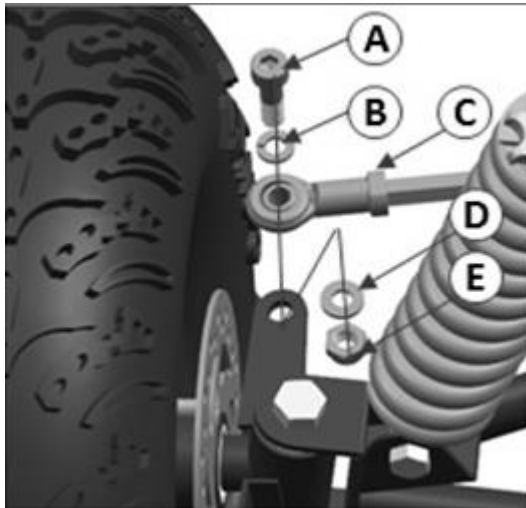

A :Bolt M8*30 /2pcs

B: Spring washer $\Phi 8$ / 2pcs

C: Tie rod L&R/2pcs

D: Washer $\Phi 8$ / 2pcs

E: Nut N8 / 2pcs

1. Align the hole of tie Spring washer (B), tie rod end ball (C), Washer (D) in sequence.
2. Mount the bolt(A) and tighten the nut (E) securely with 13mm - 15mm open end wrench and 6mm hex wrench.

ASSEMBLY BUMPER

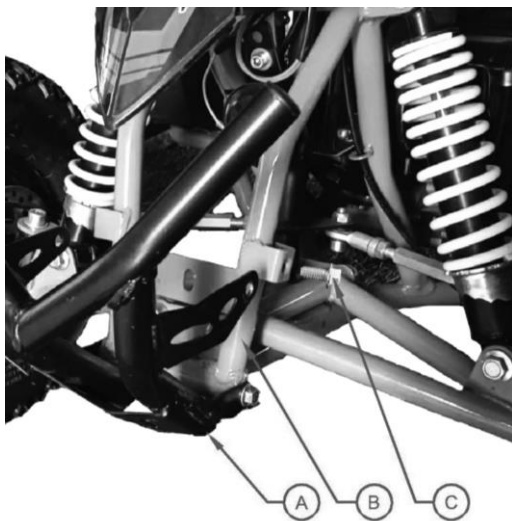

A: Bumper / 1pc

B: Frame / 1pc

C: Bolt M8*16 / 4pcs

1. Align the bottom mounting hole of bumper (A) to the frame (B) bottom joint and mount the bolt (C), NOT tighten the bolt to keep the bumper free move.
2. Turn upwards the bumper (A) to align the upper mounting hole of bumper to the frame upper joint, then mount the bolt (C)
3. Tighten the bolt (C) securely with 10mm and 13mm open end wrench

ASSEMBLY REAR CARRIER & EXHAUST

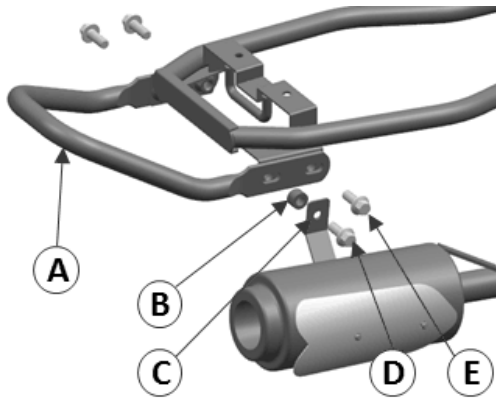

- A: Rear carrier / 1pc
- B: Rubber bush/ 1pc
- C: Exhaust bracket / 1pc
- D: Bolt M8*25 / 1pc
- E: Bolt M8*16 / 3pcs

1. Align the inside mounting hole of rear carrier (A) to the frame joint and mount the bolt (E).
2. Align the outside hole of tie rear carrier (A), rubber bush (B), exhaust bracket (C) in sequence.
2. Tighten the bolt(D) securely with 10mm open end wrench and 6mm hex wrench.

ASSEMBLY FRONT BRAKE CALIPER

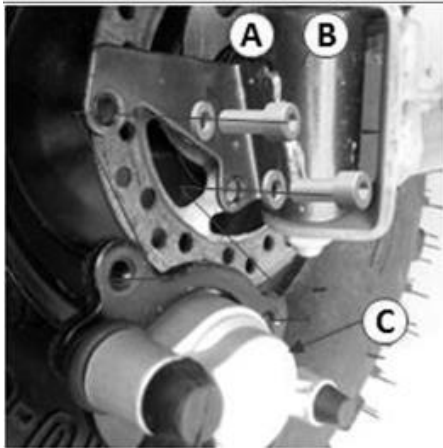

- A: Spring washer $\Phi 6$ / 4pcs
- B: Bolt M6*12 / 4pcs
- C: front brake caliper L&R

1. Place the brake disc into the front brake caliper (C) with the hole in alignment.
2. Mount the spring washer (A) and then tighten the bolt (B) securely with 5mm hex wrench.

ASSEMBLY HANDLEBAR

WARNING:

Failing to properly adjust and tighten the bolts that affix the handlebars can cause you to lose control and crash.

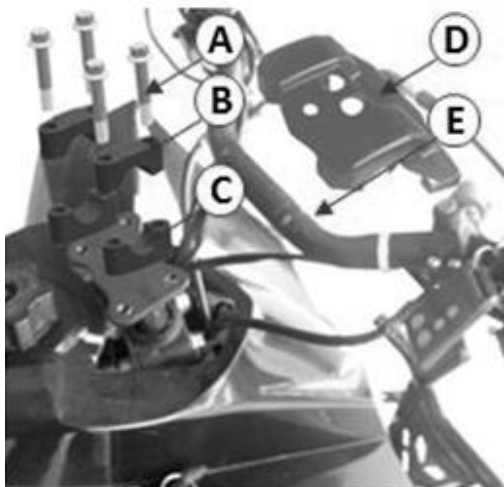

- A: Bolt M8x50 / 4pcs
- B: Upper Clamp / 2pcs
- C: Bottom Clamp /2pcs
- D: handlebar cover/2pcs
- E: Handle bar / 1pc

1. Put the bottom clamp(C) on the steering rod plate with the screw hole in alignment, and place the handlebar (E) in the bottom clamp, then cover the upper clamp (B) on the handlebar and install the 4pcs bolt (A).
2. Place the handlebar in the upright and vertical position, then tighten all the bolts securely with 10mm open end wrench.
3. Put the cover on the handle bar.

SAFETY REMINDERS

PRE-RIDE CHECKLIST

Loose Parts

Check and secure all fasteners before every ride. Make sure steering stem clamp bolts are locked properly in place. There should not be any unusual rattles or sounds from loose parts or broken components. If you are not sure, ask an experienced mechanic to check.

Brake

Check the brake for proper function. When you squeeze the lever, the brake should provide positive braking action. When you apply the brake with the speed control on, the brake cut-off switch will stop the motor.

Frame, suspension and Handlebars

Check for cracks or broken connections. Although broken frames are rare, it is possible for an aggressive driver to bash into a curb or wall and wreck and bend or break a frame. Get in the habit of inspecting yours regularly.

Tire Inflation

Periodically inspect the tires for excess wear, and regularly check the tire pressure and re-inflate as necessary. If you get a flat tire, the inner tube can be patched or a new tube can be purchased from Razor or an authorized repair center.

Safety Gear

Always wear proper protective equipment such as an approved safety helmet, elbow pads and kneepads. Always wear shoes (lace-up shoes with rubber soles), never drive barefooted or in sandals, and keep shoelaces tied and out of the way of the wheels, motor and drive system

Inflating the Tires



NOTE: The tires are inflated when shipped, but they invariably lose some pressure between the point of manufacturing and your purchase. Always inflate the tires to the correct PSI before first time use.

Please read the specification sheet to get the information of tire pressure.

Using a bicycle-style tire pump to inflate the tire to the PSI indicated on the sidewall of the tire.

Note: The pressurized air supplies found at gasoline stations are designed to inflate high-volume automobile tires. If you decide to use such an air supply to inflate your tires, first make sure the pressure gauge is working, then use very short bursts to inflate to the correct PSI. If you inadvertently over-inflate the tire, release the excess pressure immediately.

Important information of use guider for tire

Note: Tire is the only contact between the vehicle to the road, the safety of various driving activity depends on the small area of tire where contact with the road. Therefore, it is very important to keep the tire in good condition any time and use the correct size and standard tire to replace the old ones.

Guide:

Tire assembly and disassembly

It is strongly recommended that the tire assembly and disassembly should be done by an authorized technician with necessary skills.

Tire inflating pressure

It is very important to keep the tire in proper pressure and check the tire pressure before use. The inflating should be done while the tire is cold.

Tire maintenance

Tire tread depth should be checked regularly.(Shallower tread means less grip of tire). You must stop to use the vehicle if the tire is pierced, disassemble the tire and check it carefully. Tire maintenance should be done by an authorized technician. Tire should be replaced immediately when it is distorted or damaged.

Tire replacement

It is important to use the correct size and standard tire as per our specification (see details in technical specification sheet)

Don't use the used tire if you are not sure its previous service condition.

Tire aging

Tire aging is unavoidable even the tire is not ever used or just used a few times. Tire aging is mainly reflected in the cracked section on side of tire and tire tread, sometimes the tire is distorted as well. The used and aged tire should be checked and confirmed if it is ok to use again by an authorized technician

TECHNICAL SPECIFICATION SHEET

Engine type	90/110cc, single cylinder, 4stroke, forced air cooling
Power output	90CC:3.6kw/7500±500 pm 110CC:4.8kw/7500±500 pm
Max torque	90CC: 6.2 N.m/ 5500±500 rpm 110CC: 7.5 N.m/ 5500±500 rpm
Displacement (ml)	90cc:86ml / 110cc:107ml
Idle speed	1500±100 r/min
Clutch	Wet & centrifugal
Lubrication	Press/Splash
Spark plug type	A7TC
Ignition	C.D.I
Final drive	13T / 37T, 420# chain
Engine oil	15W/40-SE
Fuel	Green Petrol ≥90#
Compression Ratio	9.0 : 1

Transmission	automatic with centrifugal clutch
Start method	Electric start only
Battery	12V 4AH
Max.speed (km/h)	50
Max load capacity (kgs)	65
Front suspension	double mechanical damper
Rear suspension	mono shock absorber
Tyre (standard 6 “)	front 14*4.10-6” rear 14*5.0-6” with 10.00 P.s.i operation pressure and 24 P.s.i Max. inflate
Brake system	Front and rear disc brake
Fuel tank capacity	2L
Dry Weight (kgs)	62
Dimension (mm)	1150*720*760
Seat height (mm)	540
Ground clearance (mm)	130
Wheelbase (mm)	750

MAIN PARTS DESCRIPTION



- 1: Fuel tank
- 2: Air filter
- 3: Battery
- 4: Rear wheel
- 5: Rear shock
- 6: Engine
- 7: Carburetor
- 8: Front wheel

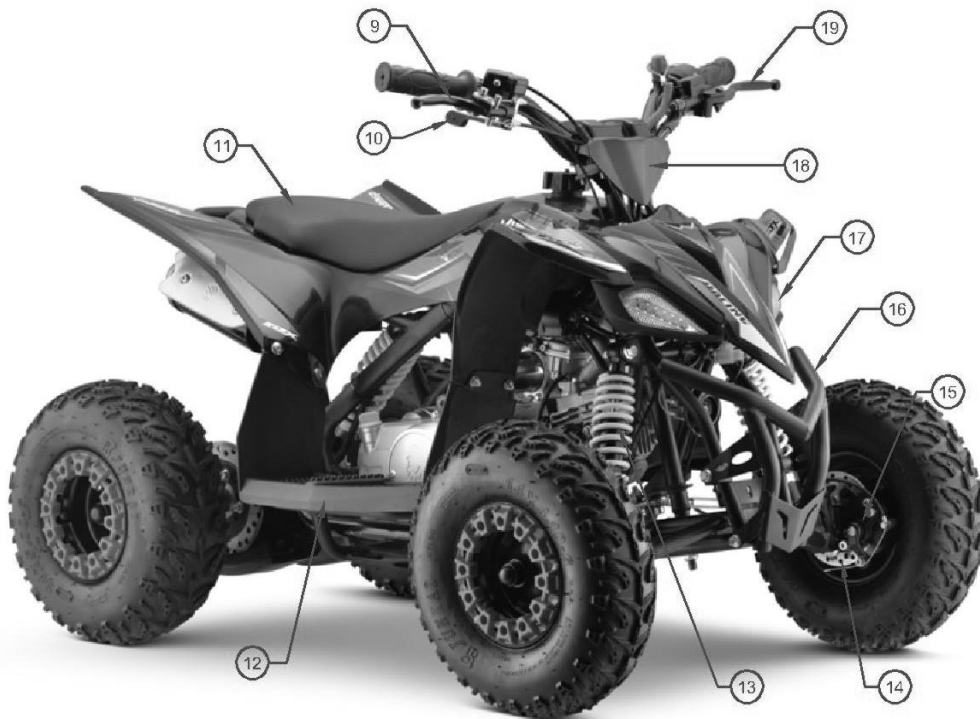

- 9: Front brake lever
- 10: Throttle
- 11: Seat
- 12: Footrest
- 13: Front shock
- 14: Front brake disc
- 15: Front brake caliper
- 16: Bumper
- 17: Front lamp
- 18: Handlebar cover
- 19: Rear brake lever



- 20: Key ignition
- 21: Emergency kill switch
- 22: Multi-function switch
- 23: Rear carrier
- 24: Rear lamp
- 25: Exhaust
- 26: Chain cover
- 27: Rear brake caliper
- 28: Rear brake disc
- 29: Chain

PIN & ENGINE CODE

PIN is stamp marked on an aluminum plate riveted on the rear swing arm.

There are the product main specification information on this PIN plate.

PIN means the Product Identify Number which is unique for each unit.

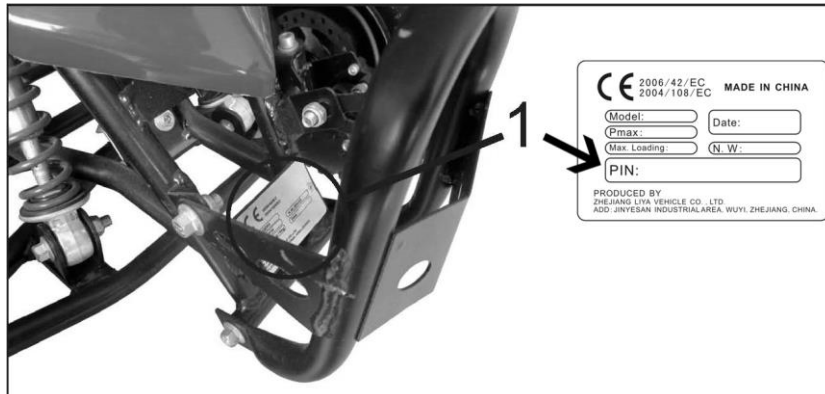

Engine code



Engine code: ☆ ☆

The engine code is stamped on the left side of the crankcase.

HANDLEBAR CONTROLS

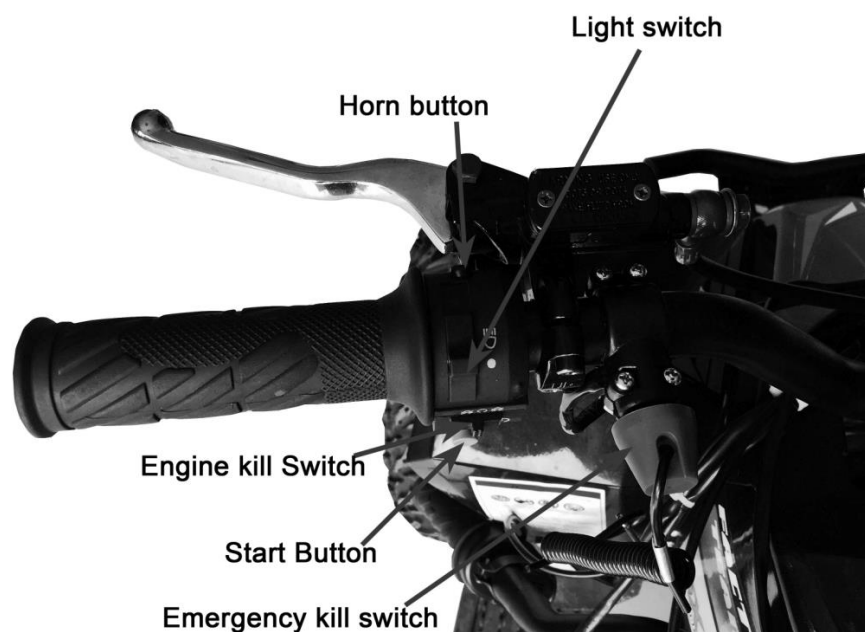

Engine kill Switch

In normal, the kill switch is set on multi-function switch at the right side of handlebar. You can see the mark ON/OFF below the switch. To stop the engine, set the switch to left or to right.

Start Button

Press the start button with the vehicle in braking to start up the engine.

Emergency kill switch

The emergency kill switch is set on the left side of handlebar with a red cap and rope. Pull out the cap to stop the engine.

WARNING

Never tie the emergency kill switch rope to the rider. In an emergency, the supervisor should pull the rope from behind the vehicle to activate the safety switch so as to stop the engine immediately.

Horn button

Press the horn button to start horn.

Light Switch

Set the switch up to open the light, and set the switch down to close the light.

IGNITION SWITCH

The ignition switch is situated on the front right of the vehicle body.

“OFF” and “ON” on the switch indicate:

OFF: Engine and lights cannot be operated and the key can be removed.

ON: Engine and lights can be operated and the key cannot be removed.

ACCELERATION SPEED – LIMITING DEVICE

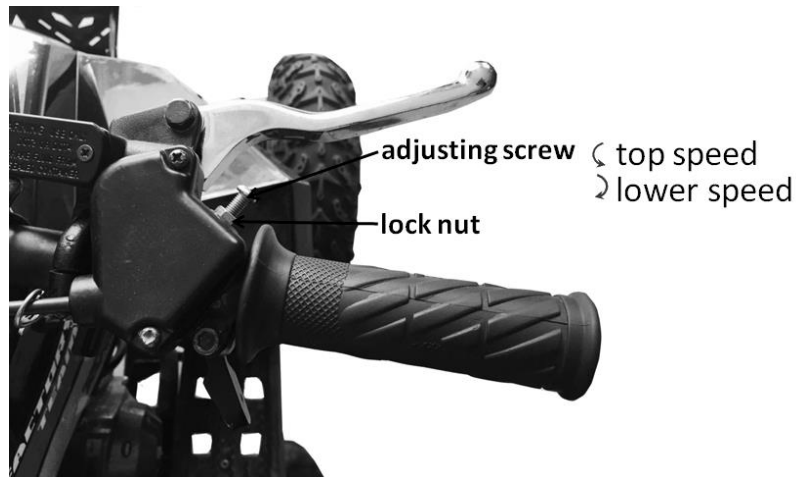

Turn loose the lock nut and screw in the adjusting screw to decrease the acceleration speed, or screw out the adjusting screw to increase the acceleration speed.

CAUTION

It's better for inexperienced riders to set the top speed lower so as to avoid accidents.

FUEL AND FUEL TANK

Fuel is a key factor in deciding the exhaust emissions amount from the engine, so selection of

the fuel must follow the rules below.

Selected fuel must be leadless or low-lead gasoline with No.RQ-90 or higher.

Fuel tank capacity is 2L.

WARNING

- Gasoline is extremely flammable and is explosive under certain conditions. Refuel in a well-ventilated area with the engine stopped. Do not smoke or allow flames or sparks in the area where gasoline is stored or where the fuel tank is refueled.
- Before refueling, make sure to filter fuel first.
- Be careful not to spill fuel when refueling. Spilled fuel or fuel vapor may ignite. If any fuel is spilled, make sure the area is dry before starting the engine.
- Avoid repeated or prolonged contact with skin or breathing of vapor.
- KEEP OUT OF REACH OF CHILDREN.

PER-RIDE INSPECTION

WARNING

If the Pre-ride Inspection is not performed, severe injury to personal or damaged to equipment may occur.

Inspect your motorcycle every day before you ride it. The items listed here will only take a few minutes to inspect, and in the long run they can save time, expense, and your life.

1. Engine oil level – add engine oil if required.
2. Fuel level-fill fuel tank when necessary. Check for leaks.
3. Front and rear brakes - check operation and if necessary, adjust free play.
4. Tyres-check condition and pressure.
5. Throttle operation-check for smooth opening and full closing in all steering positions; check for throttle grip free play and throttle cable in Lubricating and connecting.
6. Fastener – check that all nuts, screws and bolts are fixed securely.
7. Steering system – check for its smoothness and reliability .Correct any discrepancy before you ride. Contact you dealer for assistance if you cannot correct the problem.

START TO RIDE

Always follow the proper starting procedure described.

WARNING

Never run the engine in an enclosed area. The exhaust emissions contain poisonous carbon monoxide (CO) gas that can cause loss of consciousness and lead to death.

1. Place the vehicle on a level ground.
2. Insert the ignition key into the ignition switch and turn to (ON).
3. Open the chock lever
4. Catch the brake lever and press the start button to start the engine while rotating the throttle lever slightly.
5. close the chock lever

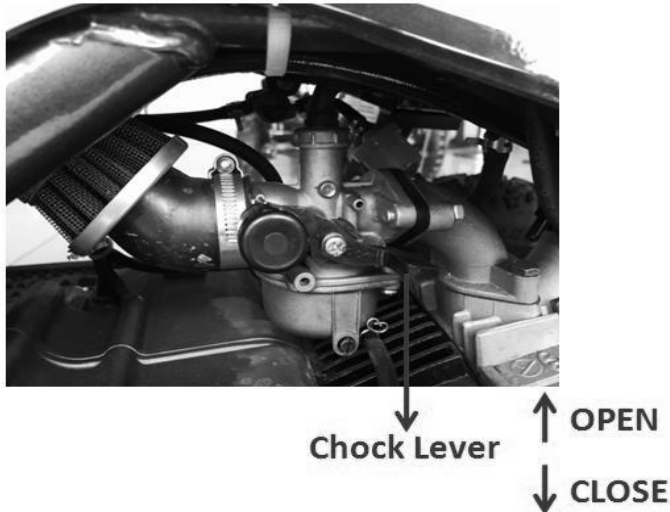

BREAKING-IN PERIOD

Help assure your vehicle's future reliability and performance by paying extra attention to how you ride during the first two-week riding.

During the period, avoid full-throttle riding and loading the engine heavily; be sure to keep changing speed.

CAUTION

After the breaking-in period, PLEASE be sure to conduct maintenance according to the maintenance schedule so as to keep the vehicle in a good condition, which will extend the service life of the engine obviously.

RIDING

WARNING

Be sure to review and understand Vehicle Safe Riding Warnings before you ride.

1. After the engine has been warmed up, the vehicle is ready for riding.
2. Check again the braking of the vehicle.
3. Press the throttle lever and accelerate gradually and the vehicle moves forward.
4. To speed down the vehicle, reduce the throttle while carry out braking. Adjust the throttle with brake using in meantime for smooth deceleration.

CAUTION

Both the front and rear brakes should be used in meantime, but the brake should not be applied strongly to lock the wheel, or braking effectiveness will be reduced and control of the vehicle will be more difficult.

CHECK AND CHANGE OF ENGINE OIL

ENGINE OIL

The quality of the engine oil plays a vital role in deciding the engine performance and service life. Engine oil must be selected in accordance with the rules below and other oils are forbidden to be used.

Engine oil recommended: gasoline engine oil Clas SAE15W/40-SE or Class SE, SF, SC from API Service Classification.

The vehicle has been filled with the engine oil Clas SAE 15W/40-SE class before being delivered, and the Lubricant is only suitable at a temperature range from 40°C to -10°C. If other motor oil is to be used instead, the alternative must be technically equivalent in every respect. Viscosity varies with regions and temperatures, so the Lubricant has to be selected according to our recommendation. If the gasoline engine oil Class SAE15W/40-SE. can not be obtained when in need, the gasoline engine oil No.HQB-10 (or No. HQB-6 in regions where the temperature is under -10 °C) is available.

Before replacing the Lubricant, please drain the oil out completely remaining in the crankcase, and clean the inside by clean the inside by clean kerosene, then fill new one instead.

WARNING

Running the engine with insufficient oil can cause serious damage to engine.

Check of Engine Oil Level



Oil filter cap dipstick

Check the engine oil level each time before riding the vehicle.

The level must be maintained between the upper and lower level marks on the dipstick.

1. Start the engine and let it idle for a few minutes.
2. Stop the engine and put the vehicle on a level ground.
3. After a few minutes, remove the oil filter cap dipstick, wipe it clean, and reinsert the dipstick without screwing it in, remove the dipstick. The oil level should be between the upper and lower level marks on the dipstick.

Change of the Engine Oil

The engine oil quality is the chief factor affecting the engine service life. Change the engine oil as specified in the maintenance schedule.

1. Drain out the engine oil in the crankcase completely.
2. Clean the crankcase inside with cleaning kerosene.
3. Add specified engine oil about 0.8L.

CAUTION

Running the engine with insufficient oil would cause serious damaged to the engine.

When running in very dusty conditions, oil changes should be performed more frequently than specified in the maintenance schedule.

Please dispose of used engine oil in a manner that is compatible with the environment. We suggest you take it in a sealed container to your local recycling center or service station for reclamation. Do not throw it in the rubbish or pour it on the ground or down a drain.

SPARK PLUG



Spark plug

Plug recommended:C7HSA NGK

Check and replace

1. Disconnect the spark plug cap from the spark plug.
2. Clean any dirt from around the spark plug base. Remove the spark plug using the plug wrench containing in the tool kit.
3. Inspect the electrodes and center porcelain for deposits, erosion or carbon fouling. If the erosion or deposit is heavy, replace the plug. Clean a carbon or wet-fouled plug with a plug cleaner, or use a wire brush.
4. Check the spark plug gap using a wire-type feeler gauge. If adjustment is necessary, bend the side electrode carefully.

The spark plug gap should be 0.6-0.8mm.

Make sure the plug washer is in good condition.

5. With the plug washer attached, thread the spark plug in by gang first to prevent cross threading, and then tighten up it by the spark plug wrench.
6. Reinstall the spark plug cap.

- ① Side electrode
- ② Center electrode

AIR FILTER



Air filter

The air filter should be serviced at least once every 30-day's drive. Service more frequently when riding in unusually wet or dusty areas. See your dealer for further information.

1. Remove the air cleaner from the carburetor
2. Disassemble it and take out filter element.
3. Wash the filter element in clean, nonflammable or high flash point solvent and let it dry.

WARNING

Never use gasoline or low flash point solvents for cleaning the filter element, otherwise, a fire or explosion could result.

4. Soak it in gasoline engine oil Class 15W/40QE until saturated, and then squeeze out the excess oil.
5. Clean the inside and outside of the air cleaner housing.
6. Install the removed parts in the reverse procedure of removal.

CAUTION

- It is forbidden to start the engine without the air cleaner core, or premature wear of the piston and cylinder may produce.
- Make sure the air cleaner core is intact.
- Prevent the air cleaner core from getting water when washing the vehicle.

IDLE SPEED

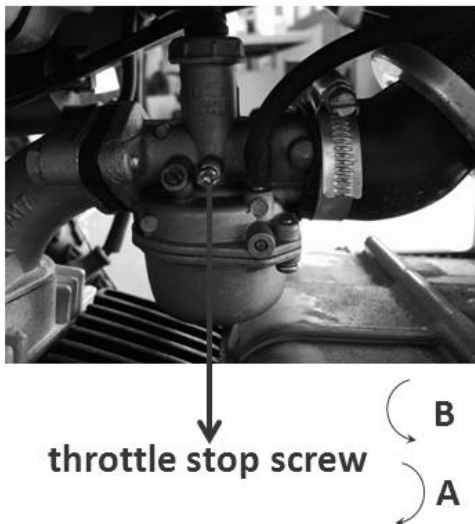

The engine must be at normal operating temperature for accurate idle speed adjustment.

NOTE

Do not attempt to compensate for fault in other systems by adjusting idle speed. Contact your dealer for regularly carburetor adjustments.

1. Warm up the engine.
2. Connect a tachometer to the engine (a remote-controlled one can be used).
Turn the throttle stop screw clockwise (in the direction of the arrowhead A) will increase idle speed while will decrease it running counterclockwise (in the direction of the arrowhead B).
3. When the engine has no idle speed or runs at a decreased speed, set the throttle stop screw in the middle between the two limit position to help mix air and fuel.
4. Run the engine again, re-adjust the throttle stop screw if necessary.

CAUTION

Since the carburetor is a precision apparatus, don't disassemble it without the professional knowledge.

BRAKE SYSTEM CHECKING

The brake system should be checked every time before you ride the vehicle.

1. Check the brake main cylinder for proper oil level.
2. Check to see there is no leakage from the brake system.
3. Check the brake hose and main cylinder for cracks.
4. Check the brake disc for wear.
5. Check the brake lever for proper free play.

CAUTION

The hydraulic disc brake is designed to operate under high pressure.

For the sake of safety and reliability, the service life of brake hose, main cylinder and brake liquid must not be beyond the limit specified in the manual.

If the hydraulic disc brake system needs to be maintained or repaired, conduct the problem by your dealer only.

If you feel soft when operating the brake lever, it means there is air inside the brake system. In this case, air should be discharged from the brake system before riding the vehicle, otherwise, the brake feature will drop considerably, even cause an accident. For which purpose, see your dealer.

BRAKELIQUID

Be careful to check the brake liquid in the main cylinder located on the right handlebar for proper level, and the specified liquid if necessary. As the brake pads wear, the brake liquid level drops. The brake should be inspected periodically.

WARNING

- Brake liquid is strong irritant avoid contact with skin or eye. In case of contact, flush thoroughly with water and call a doctor if your eye were exposed.
- Keep liquid used for the brake system is non-petroleum brake oil No.4604. Never mix with other oil such as silicon oil, or serious damage to the brake system may occur.

CAUTION

- It is forbidden to use the used liquid or the liquid placed in the open container.
- Never use the liquid which has been stored for long time, because it contains moisture inhaled from air.

EXHAUST MUFFLER

Clear away regularly carbon deposit in the exhaust pipe; check the exhaust pipe inside for crack and washer damage and repair or replace if necessary.

BATTERY

Battery is under the seat, remove the seat firstly if you want to check or change the battery. Battery electrolyte is poisonous, so be sure not to discard the battery at will. Handle in accordance with national or local national or local environmental protection rules.

CAUTION

Before handing the vehicle over for long-term storage, remove the battery from the vehicle and charge it fully, and then store it in a cool, dry place. If the battery is to be left in the motorcycle,

disconnect the negative lead (-) from the battery terminal first and then positive leads (+). Do not touch the positive and negative leads with metal objects to prevent short-circuiting during the operation above.

WARNING

When removing the battery, dismantle the negative lead first, and then the positive lead. When installing it, the procedure is just opposite. **During the operations above, the ignition switch must be turned off.**

●The battery gives off explosive gases; keep sparks, flames, and cigarettes away. Provide adequate ventilation when charging or using the battery in an enclosed space.

●The battery contains sulfuric acid (electrolyte). Contacting with skin or eyes may cause severe burns. Wear protective clothing and a face shield.

If electrolyte gets in your skin, flush with water.

If electrolyte gets in your eyes, flush with water for at least 15 minutes and call a physician immediately.

●Electrolyte is poisonous. If swallowed, drink large quantities of water or milk and follow with milk of magnesia or vegetable oil and call a physician.

●KEEP OUT OF REACH OF CHILDREN

TROUBLESHOOTING

If the vehicle has some trouble, please contact your dealer for help.

CAUTION

Do not dismantle or maintain the vehicle without the professional knowledge.

CLEANING

Clean your vehicle regularly to protect the surface finish and inspect for damage, wear, and oil or brake fluid leakage.

CAUTION

High-pressure water (or air) can damage certain parts of the motorcycle.

Avoid spraying high-pressure water at the following areas; Wheel hubs; Ignition Switch; Carburetor; Handlebar Controls; Muffler Outlets; Under Fuel Tank; Under Seat

1. Wash the vehicle completely with a great deal of water.
2. Dry up the vehicle, start the engine, and let it run for several minutes.

WARNING

Braking efficiency may be temporarily impaired just after washing the motorcycle. Anticipate longer stopping distance to avoid a possible accident.

3. Test the brakes before riding the vehicle. Several applications may be necessary to restart normal braking performance.
4. Lubricate the drive chain immediately after washing and drying the motorcycle.

STORAGE GUIDE

Some measures should be taken when the vehicle is subjected to a long term storage so as to reduce the bad influence on its performance. Before the storage, make necessary maintenance to ensure the vehicle high performance after-storage.

Storage

1. Clean and dry up the vehicle and wax its surface.

2. Empty the fuel from the fuel tank and carburetor, spray some antirust.

WARNING

Gasoline is extremely flammable and is explosive under certain conditions. Perform this operation in a well-ventilated area with the engine stopped. Do not smoke or allow flames or sparks in the area where gasoline is drained or stored and where the fuel tank is refueled.

1. Drive off the spark plug to fill a little of engine oil (about 15-20 millilitre) into the cylinder; turn off the ignition switch and tread the kick-starter several times to scatter evenly the oil inside the cylinder, and then reinstall the spark plug.
2. Drive off the spark plug to fill a little of engine oil (about 15-20 millilitre) into the cylinder; turn off the ignition switch and tread the kick-starter several times to scatter evenly the oil inside the cylinder, and then reinstall the spark plug.
3. Clean and oil the drive chain.
4. Lubricate all the cables.
5. Seal the muffler outlet with plastic cloth to protect the former from moisture.
6. Cover the vehicle (don't use plastic or other coated materials) and store in an unheated area, free of dampness. Do not store the vehicle in direct sunlight.

MAINTENANCE SCHEDULE

The following maintenance schedule specifies all maintenance required under normal conditions to keep your vehicle in sound condition. Riding under unusually dusty or wet conditions, service of the vehicle should be made more often than the specified in the schedule. Maintenance work should be performed by properly trained and equipped technicians.

I: INSPECT AND CLEAN, ADJUST, LUBRICATE OR REPLACE IF NECESSARY C: CLEAN

	First week	Every 30-day's ride	Every year
Fuel system	I		
Operation of throttle		I	
Air cleaner		C	
Spark plug		I	
Idle speed of carburetor	I	I	
Drive chain	I&L	I&L	
Brake shoe wear			
Brake system	I	I	I
Nuts/bolts,/ fasteners	I	I	
Wheel	I	I	I
Steering system			I
Suspension system		I	I



Please read the owner's manual before riding.



Never operate this vehicle if you are under age 16



Never use the vehicle on public road. OFF ROAD use only.



Never ride with a passenger



Always use an approved helmet and protective gear



NEVER use with drugs or alcohol



Cold tire pressure.