

ELECTRIC MINI ATV

E-ZR50



OWNER'S MANUAL

Read and understand this entire manual before using!

NOTE: Manual illustrations are for demonstration purposes only.

Illustrations may not reflect exact appearance of actual product.
Specifications subject to change without notice.

OFF ROAD USE ONLY!!!

**NEVER OPERATE THIS VEHICLE IF YOU ARE UNDER
AGE 12!!!**

INTRODUCTION

Thank you for purchasing this mini ATV. The proper care and maintenance that your vehicle requires is outlined in this manual. Following these instructions will ensure a long trouble-free operating life of this vehicle and your satisfaction with it.

The owner's manual corresponded to the latest state of this vehicle at the time of printing. Slight deviations resulting from continuing development and design can, however, not be completely excluded. All specifications are non-binding, we reserve the right to modify or delete technical specification, parts, design, etc... without prior notice.

SAFETY WARNINGS

This vehicle is NOT A TOY and ONLY used in closed off areas remote from public road traffic.

Never permit children under age **12** to operate this ATV.

Adult's supervision is required if children under age **16**.

WARNING: Riding an electric mini ATV can be a hazardous activity. Certain conditions may cause the equipment to fail without fault of the manufacturer. Like other electric vehicles, the Mini Quad can and is intended to move, and it is therefore possible to lose control, fall off and/or get into dangerous situations that no amount of care, instruction or expertise can eliminate. If such things occur you can be seriously injured or die, even when using safety equipment and other precautions. **RIDE AT YOUR OWN RISK AND USE COMMON SENSE.**

This manual contains many warnings and cautions concerning the consequences of failing to maintain, inspect or properly use your mini ATV. Because any incident can result in serious injury or even death, we do not repeat the warning of possible serious injury or death each time such a possibility is mentioned.

APPROPRIATE RIDER USE AND PARENTAL SUPERVISION

This manual contains important safety information and use tips to help you and your child operate and handle the mini ATV. Carefully read the manual in its entirety together with your child before letting your child ride it for first time. The manual also contains important information on servicing the vehicle.

It is your responsibility to review the manual and make sure that all riders understand all warnings, cautions, instructions and safety topics and assure that the riders are able to safely and responsibly use this product and protect your child from injury. We recommend that you periodically review and reinforce the information in this manual with your child, and that you inspect and maintain your children's vehicle to insure their safety. **The recommended rider age of 12 years** is only an estimate, and can be affected by the rider's size, weight or skills. Any rider unable to fit comfortably on the mini ATV should not attempt to ride it.

It is important and necessary to conduct the technical training for your child before first use. To get the training information, please contact the dealer who you purchase the vehicle from. Before your child complete the training, do not let your child use this vehicle.

Children often underestimate or fail to recognize the dangerous situation, you should make it clear to your child that should not, under any circumstances, operate the vehicle without supervision and that your child may only drive at speed that are commensurate with the child's riding ability and other road condition.

A parent's decision to allow his or her child to ride this vehicle should be based on the child's maturity, skill and ability to follow rules.

Keep this product away from small children younger than age 12 and remember that this product is intended for use only by persons who are, at a minimum, completely comfortable and competent while operating the vehicle.

DO NOT EXCEED THE WEIGHT LIMIT OF 145LBS (65KGS). Rider weight does not necessarily mean a person's size is appropriate to fit or maintain control of the mini ATV

Do not touch the brakes or motor on your vehicle when in use as they can become very hot.

Refer to the following section on safety for additional warnings.

ACCEPTABLE RIDING PRACTICES AND CONDITIONS

Always check and obey any local laws or regulations which may affect the locations where the vehicle may be used.

Ride defensively. Watch out for potential obstacles that could catch your wheel or force you to swerve suddenly or lose control. Be careful to avoid pedestrians, skaters, skateboards, scooters, bikes, children or animals who may enter your path, and respect the rights and property of others.

The mini ATV is meant to be used on private property and on closed courses and not on public streets or sidewalks. Do not ride your mini ATV in any areas where pedestrian or vehicle traffic is present.

Do not activate the speed control on the hand grip unless you are on the MINI ATV and in a safe, outdoor environment suitable for riding.

This product was manufactured for performance and durability but are not impervious to damage. Jumping or other aggressive riding can over-stress and damage any product, including the Mini ATV, and the rider assumes all risks associated with high-stress activity.

Be careful and know your limitations. Risk of injury increases as the degree of riding difficulty increases. The rider assumes all risk associated with aggressive riding activities.

Never carry passengers or allow more than one person at a time to ride the electric mini quad.

Never use near steps or swimming pools.

Never use alcohol or drugs before or while operating

Keep your fingers and other body parts away from the drive chain, steering system, wheels and all other moving components.

Never use headphones or a cell phone when riding.

Never hitch a ride with another vehicle.

Do not ride the vehicle in wet or icy weather and never immerse the electric mini quad in water, as the electrical and drive components could be damaged by water or create other possibly unsafe conditions.

Wet, slick, bumpy, uneven or rough surfaces may increase risks of use. Do not drive the electric four wheeler in mud, ice, puddles or water. Avoid excessive speeds that can be associated with downhill rides. Never risk damaging surfaces such as carpet or flooring by use of an electric four wheeler indoors.

Do not ride at night or when visibility is limited.

PROPER RIDING ATTIRE

Always wear proper protective equipment such as an approved safety helmet, elbow pads and kneepads. A helmet may be legally required by local law or regulation in your area.

A long-sleeved shirt, long pants and gloves are recommended. Always wear athletic shoes, never drive barefooted or in sandals, and keep shoelaces tied and out of the way of the wheels, motor and drive system.

USING THE CHARGER

The charger supplier with the vehicle should be regularly examined for damage to the cord, plug, enclosure and other parts, and in the event of such a damage, the bike must not be charged until the charger has been repaired or replaced.

Use only with the recommended charger.

Use caution when charging.

The charger is not a toy. Charger should be operated by an adult.

Do not operate charger near flammable materials.

Unplug charger and disconnect from bike when not in use.

Always disconnect from the charger prior to wiping down and cleaning the vehicle with liquid.

FAILURE TO USE COMMON SENSE AND HEED THE ABOVE WARNINGS INCREASES RISK OF SERIOUS INJURY. USE WITH APPROPRIATE CAUTION AND SERIOUS ATTENTION TO SAFE OPERATION.

WARNING STICKER LOCATION

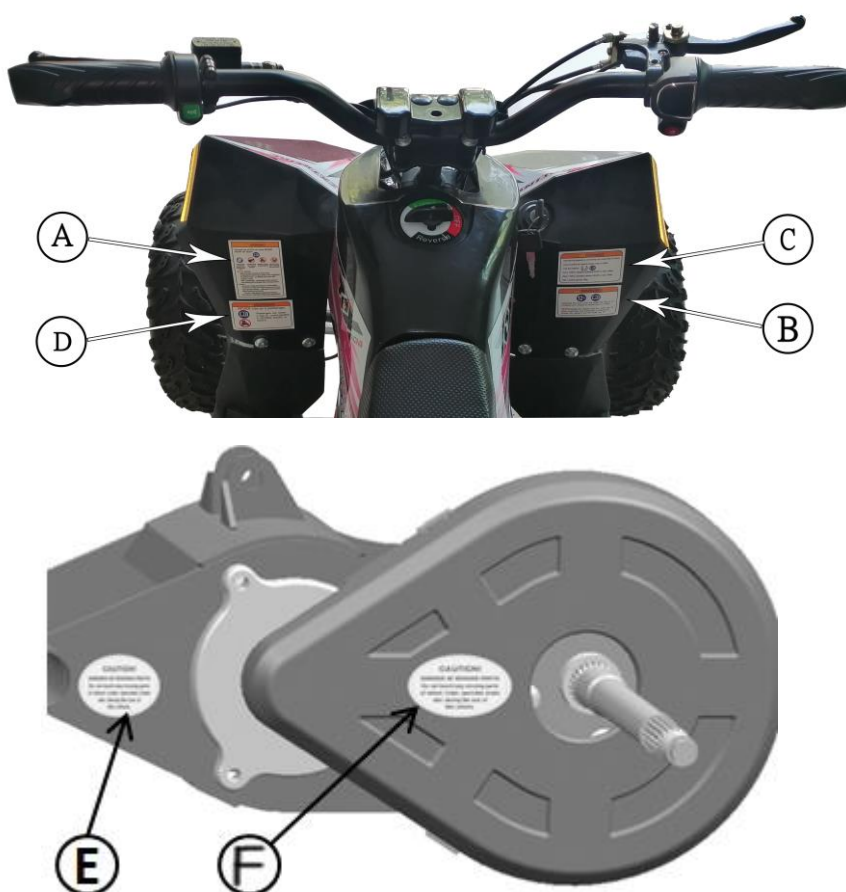

Sticker A as below is located on the left front fender.



Sticker B as below is located on the right front fender



Sticker C as below is located on the right front fender

Sticker D as below is located on the left front fender.



Sticker E as below is located on the rear swing arm

Sticker F as below is located on the chain cover



LOCATION OF PIN

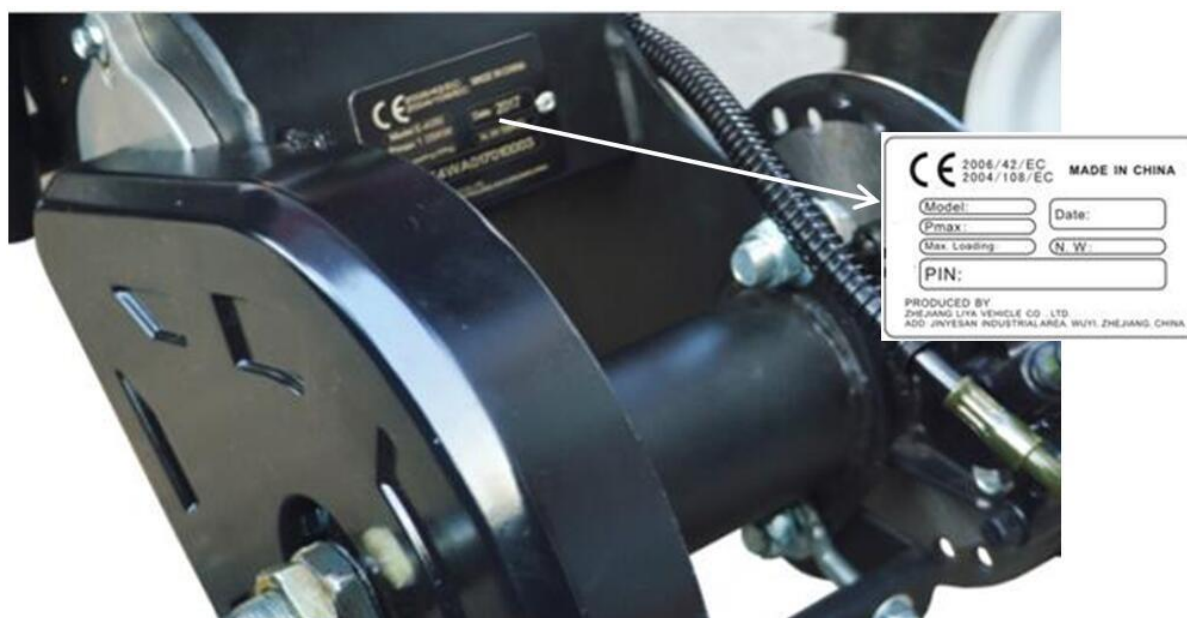

PIN is stamp marked on an aluminum plate that is riveted on the rear swing arm

PIN means the Product Identify Number which is unique for each unit.

BEFORE YOU BEGIN

Remove contents from box. Remove the foam separators that protect the components from damage during shipping. Inspect the contents of the box for scratches in the paint, dents or kinked cables that may occur during shipping. Because the product was 85 percent assembled and packed at the factory, there should not be any problems, even if the box has a few scars or dents.

Estimated Assembly and Set-Up Time

We recommend assembly by an adult with experience in motorbike or bicycle mechanics. Allow up to 30-60 minutes for assembly

Required Tools

Some tools may be supplied; however, we recommend the use of mechanic's grade tools. Use the supplied tools only as a last resort.

The list of tool required is as follows:

- Open end wrench 10mm / 13mm-15mm / 14mm-17mm / 24mm
- Allen wrench 5mm / 6mm / 10mm • Bicycle style tire pump with pressure gauge

Assembly illustration and instruction

ASSEMBLY REAR WHEEL



- A: Nut M16 1pc
- B: Washer Φ 16.5*30*3 1pc
- C: Rear wheel
- D: split pin 2pcs
- E: Rear axle

1. Fix the wheel(C) through the axle.
2. Mount the spring washer (B) and then tighten the nut (A) securely with 24mm open end wrench.
3. Install the 2pcs split pin.

ASSEMBLY FRONT SHOCK ABSORBER

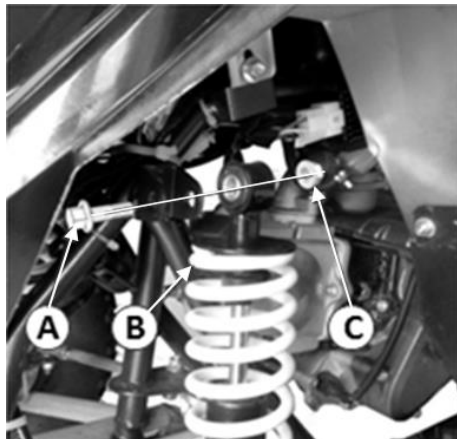

- A: Bolt M10*40 2pcs
- B: front shock
- C: Nut M10 2pcs

1. Uplift the frame to align the shock (B) mounting hole to the shackle joint hole.
2. Fix the bolt (A) through the shock mounting hole and shack joint and tighten the nut (C) securely with 13mm -15mm and 14mm -17mm open end wrench

ASSEMBLY FRONT WHEEL

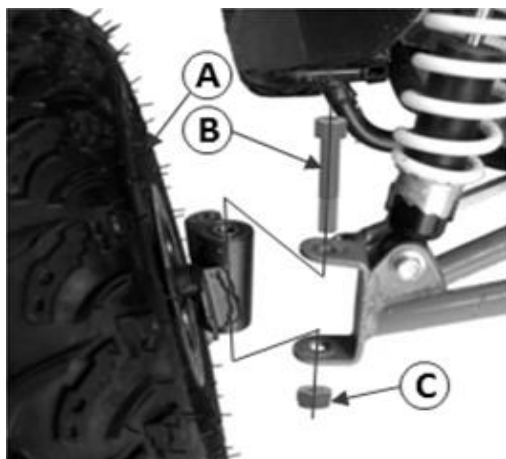

- A: Wheel suspension left and right
- B: Bolt M10*85*1.5 2pcs
- C: Nut M10 2pcs

1. Put the front wheel suspension (A) into the front swing arm joint, align the bearing hole to the joint upper and bottom hole.
2. Mount the bolt (B) through the hole and twist the nut (C),tighten it securely with 14mm - 17mm open end wrench and 10mm allen wrench.

ASSEMBLY TIE ROD

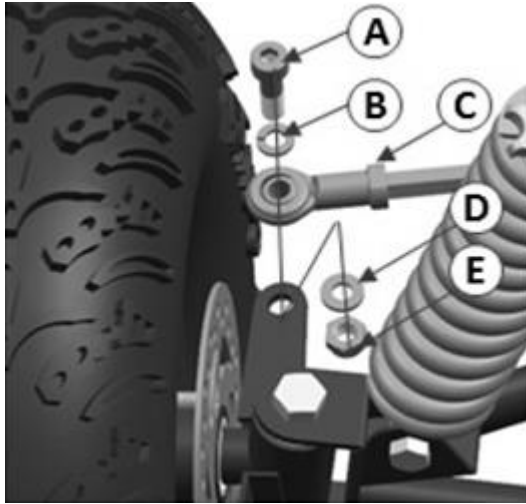

- A :Bolt M8*30 2pcs
- B: Spring washer Φ 8 2pcs
- C: Tie rod left and right 2pcs
- D: Waher Φ 8 2pcs
- E: Nut N8 2pcs

1. Align the hole of tie Spring washer (B), tie rod end ball (C), Waher (D) in sequence.
2. Mount the bolt(A) and tighten the nut (E) securely with 13mm - 15mm open end wrench and 6mm allen wrench.

ASSEMBLY BUMPER

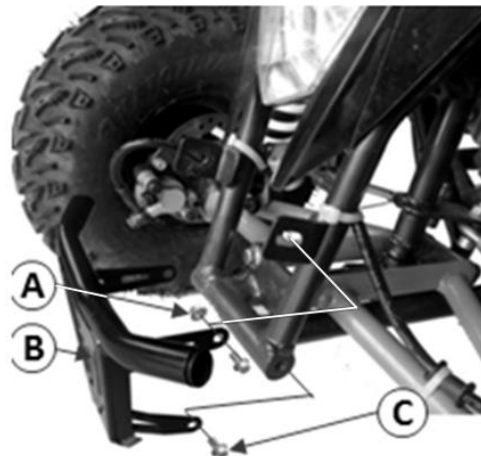

- A: Nut M8 2pcs
- B: Bumper
- C: Bolt M8x16 4pcs

1. Align the bottom mounting hole of bumper (B) to the frame bottom joint and mount the bolt (C), NOT tighten the bolt to keep the bumper free move.
2. Turn upwards the bumper to align the upper mounting hole of bumper to the frame upper joint, then mount the bolt (C) and twist the nut (A).
3. Tighten the bolt (C) and nut(A) securely with 10mm and 13mm open end wrench

ASSEMBLY FRONT BRAKE CALIPER

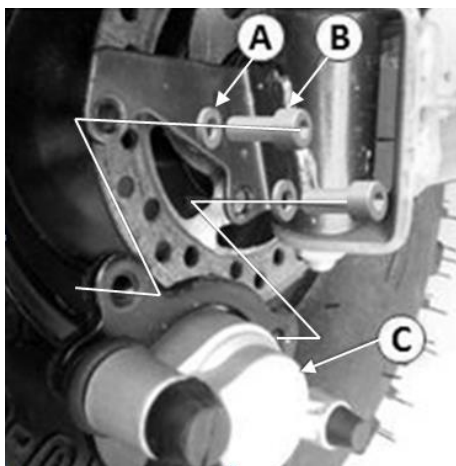

- A: Spring washer Φ 6 4pcs
- B: Bolt M6*12 4pcs
- C: front brake caliper

1. Place the brake disc into the front brake caliper (C) with the hole in alignment.
2. Mount the spring washer (A) and then tighten the bolt (B) securely with 5mm allen wrench.

ASSEMBLY HANDLEBAR

WARNING:

Failing to properly adjust and tighten the bolts that affix the handlebars can cause you to lose control and crash.

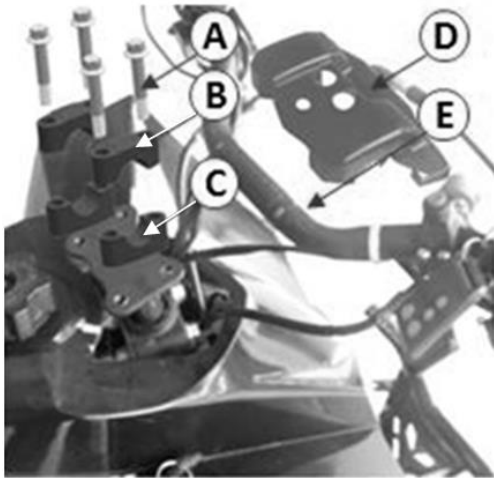

A: Bolt M8x50 4pcs B: Upper Clamp
C: Bottom Clamp D: handlebar cover

E: Handle bar

1. Put the bottom clamp(C) on the steering rod plate with the screw hole in alignment, and place the handlebar (E) in the bottom clamp, then cover the upper clamp (B) on the handlebar and install the 4pcs bolt (A).
2. Place the handlebar in the upright and vertical position, then tighten all the bolts securely with 10mm open end wrench.
3. Put the cover on the handle bar.

HANDLE DRIVE CONTROLS

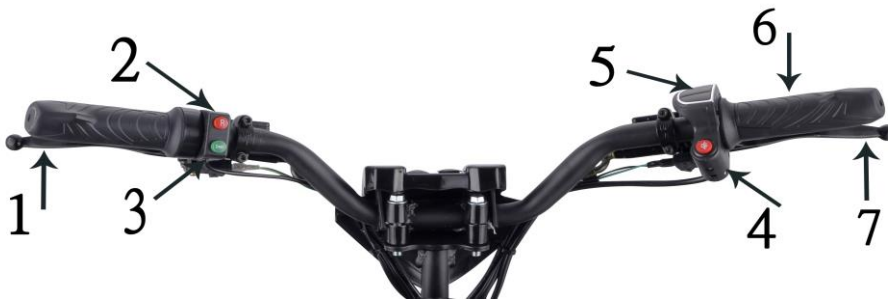

1: Front brake lever

3: Horn button switch

5: Electricity volume meter

2 :Forward & Reverse Switch--RED

4: Lamp on/off switch---GREEN

6: Accelerator grip

7: Rear brake lever

A parking brake is available on the right handle



Pull on the lever and push the button to set it .
To remove it, pull again the lever and it will be automatically released.

Remark:

1:Accelerator works while the KEY SWITCH in at ON position.

2:Press the reverse switch to move back, and reset the switch(press again) to go forward.

Inflating the Tires



NOTE: The 6" rear tires are inflated when shipped, but they invariably lose some pressure between the point of manufacturing and your purchase. Always inflate the tires to the correct PSI before first time use.

Please read the specification sheet to get the information of tire pressure.

Using a bicycle-style tire pump to inflate the tire to the PSI indicated on the sidewall of the tire.

Note: The pressurized air supplies found at gasoline stations are designed to inflate high-volume automobile tires. If you decide to use such an air supply to inflate your tires, first make sure the pressure gauge is working, then use very short bursts to inflate to the correct PSI. If you inadvertently over-inflate the tire, release the excess pressure immediately.

Important information of use guider for tire

Note: Tire is the only contact between the vehicle to the road, the safety of various driving activity depends on the small area of tire where contact with the road. Therefore, it is very important to keep the tire in good condition any time and use the correct size and standard tire to replace the old ones.

Guide:

Tire assembly and disassembly

It is strongly recommended that the tire assembly and disassembly should be done by an authorized technician with necessary skills.

Tire inflating pressure

It is very important to keep the tire in proper pressure and check the tire pressure before use. The inflating should be done while the tire is cold.

Tire maintenance

Tire tread depth should be checked regularly. (Shallower tread means less grip of tire). You must stop to use the vehicle if the tire is pierced, disassemble the tire and check it carefully. Tire maintenance should be done by an authorized technician. Tire should be replaced immediately when it is distorted or damaged.

Tire replacement

It is important to use the correct size and standard tire as per our specification (see details in technical specification sheet)

Don't use the used tire if you are not sure its previous service condition.

Tire aging

Tire aging is unavoidable even the tire is not ever used or just used a few times. Tire aging is mainly reflected in the cracked section on side of tire and tire tread, sometimes the tire is distorted as well. The used and aged tire should be checked and confirmed if it is ok to use again by an authorized technician

2-FUNCTION ADJUSTABLE SWITCH

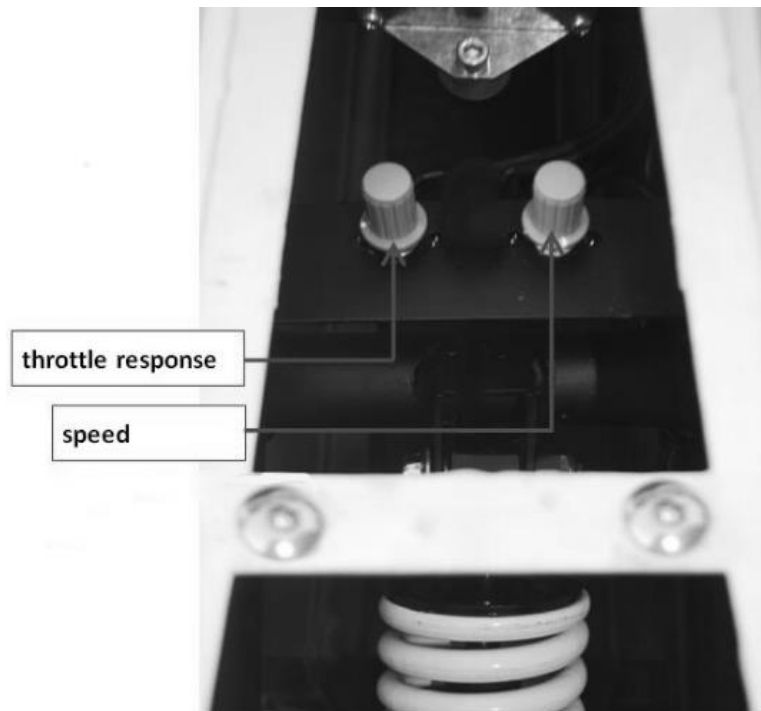

The 2-function adjustable switch is located under the seat (see above picture).

There are 2 letters standing for the different functions as follows,

R: Throttle response is adjustable from 0.2S to 1S in clockwise rotation



S: Top speed is adjustable from 8KM /H to 28KM/H in clockwise rotation

OPTIONAL PART ---REMOTE CONTROL

The remote control unit (No.1 in above picture) is located under the seat, and the switch

Stop the motor: press the button  (No.3 in above picture)

Start the motor: quickly press the button  2 times (No.2 in above picture)

Caution: The remote control works effectively within 30 meters only.

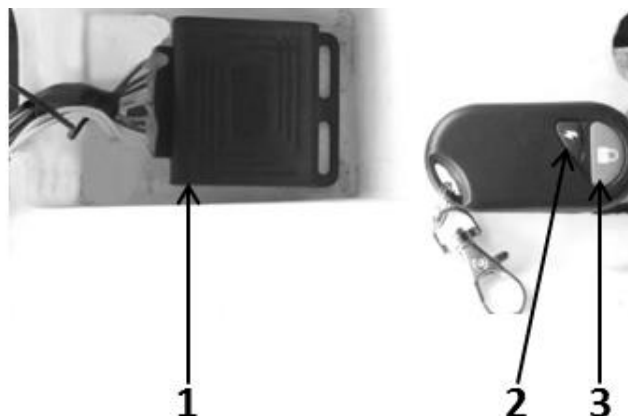

TECHNICAL SPECIFICATION SHEET

Motor type 1	1000W 36V
Motor type 2	1500W 48V
MAX. Power output 1000W36V	1.08KW/2500RPM
MAX. Power output 1500W48V	1.62KW/2950RPM
Max torque (1000W motor)	3.22Nm /2500RPM
Max torque (1500W motor)	5.48Nm/2780RPM
Battery	3 x 12V 12A lead acid battery
	48V10A / 48V 13A lithium battery
Charger INPUT for 36V lead acid battery	100-240V/50-60 Hz/1.5A
Charger OUTPUT for 36V lead acid battery	44.0V-1.5A
Charger INPUT for 48V lithium battery	100-240V/47-63 Hz/2.0A
Charger OUTPUT for 48V lithium battery	54.6V-2.0A
Non-load input current	≤115mA
Maximum motor current controller output	32A±1.0A/1000W36V 30A±1.0A/1200W48V , 35A±1.0A/1500W48V
Transmission	Chain drive
Front suspension	double mechanical damper
Rear suspension	mono shock absorber
Tyre	Tubelss tyre,front 14*4.10-6, rear 14.00 x 5-6 with 10.00 P.s.i. operation pressure and 24 P.s.i Max. inflate .
Brake system	front and rear disc brake
Rated loading capacity	65KG
Max. speed (1000W36V)	28KM/hour
Max. speed (1500W48V)	35KM/hour
Range per charge(36V12A)	19KM
Range per charge(48V10A)	18KM
Range per charge(48V13A)	24KM
Wheelbase(mm)	780
Dry Weight --(lead acid / lithium battery)	42KG / 49KG
Dimension (mm)	1165x725x765
Min ground clearance (mm)	70
Seat height (mm)	550
Carton size (mm)	1030*640*530

PRODUCT MAIN PART DIAGRAM





1. Handlebar cover	2. Front brake lever
3. Electricity volume meter	4. Throttle
5. Rear brake lever	6. Rear wheel & tire
7. Front swing arm	8. Bumper
9. Front brake caliper	10. Front wheel & tire
11. Front lamp (L & R)	12. Key ignition
13. Reverse button switch	14. Main plastic body
15. Tail light	16. Chain cover
17. Rear brake caliper	18. Front suspension
19. Battery pack	20. Seat
21. Rear rack	22. Rear suspension
23. Motor	24. Footrest (L & R)

BEFORE RIDING

Charging the Battery

Your electric mini ATV may not have a fully charged battery; therefore it is a good idea to charge the battery prior to use.

- Initial charge time: 12 hours
- Run time: up to 45minutes
- Average battery life: 120 charge/discharge cycles
- Recharge time: Always remember to turn the power switch off and recharge for at least 10 hours after each use. When vehicle is not in regular use, recharge battery at least once a month until normal use is resumed. If you have left the power switch on or your product has not been charged for a long period of time the battery may reach a stage at which it will no longer hold a charge.

WARNING:

Always disconnect your electric mini ATV from the charger before cleaning with liquid.

The charger has a small window with two LEDs to indicate the charge status. Red LED means the battery is in charging and Green LED means the battery is full charged. Chargers have built-in over-charge protection to prevent battery from being over-charged.

Be sure to properly align the groove on the charger input port with the corresponding socket on the Mini Quad and tighten threads; otherwise, no charging action will occur.

Plug the charger main plug into the wall outlet

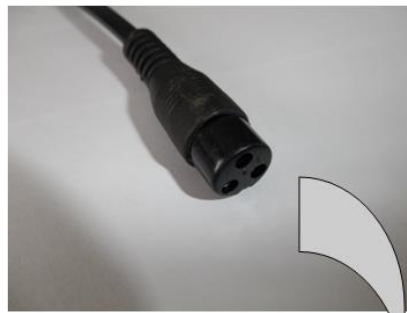

Align the groove (Poka-Yoke) of the charger's 3 pins plug into the ATV's charger connector.

Tighten the plug to secure the contact.

Warning: Failure to recharge the battery at least once a month may result in a battery that will no longer hold a charge.

How to charge the battery and change the fuse.

The fuse is pre-fitted by the factory into your battery pack. Before you use the vehicle for the first time you will need to connect the power lead to the battery pack. Once you have connected, connect your charger to the charge point on the removable battery pack and Charge the quad for 10 hours before the first use. **Ensure the keys are removed from the vehicle whenever you charge, if you leave the key turned on while charging ,it will never charge the quad fully.** For the first initial charge, leave you vehicle on charge even if the charger turns to green which will help to boost your batteries and increase overall battery life and range per charge. After the initial 10 hours,disconnect your charger once the led on the charger has turned to green. **Never leave on charge unsupervised!**

- 1) Connect the power lead to the battery pack.

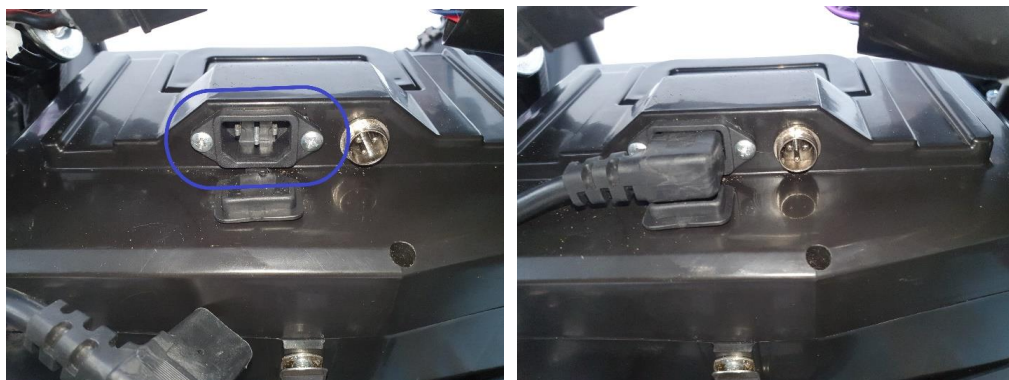

- 2) Connect the charger to the charge point.



- 3) Ensure the ignition key is removed and charge for 10 hours.

Replacing the fuse guidance

- 1) Remove your battery pack from the vehicle.
- 2) Using a cross head screwdriver undo the 6 bolts that secure the top of the battery casing.



- 3) Once you have removed the 6 screw, please carefully remove the top of the battery casing (**Please be aware there are electrical cables connecting the top section of the case to the batteries in the lower section**)



- 4) Locate the fuse holder within the battery pack. This is normally glued to the underside of the battery pack lid.

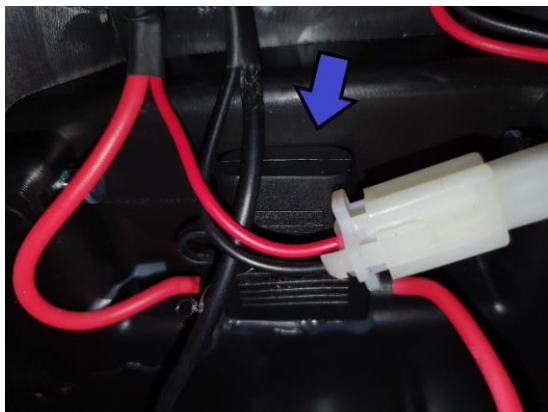

- 5) Open the fuse holder and remove the fuse and replace with your spare fuse. Reverse the procedure to refit the battery pack.

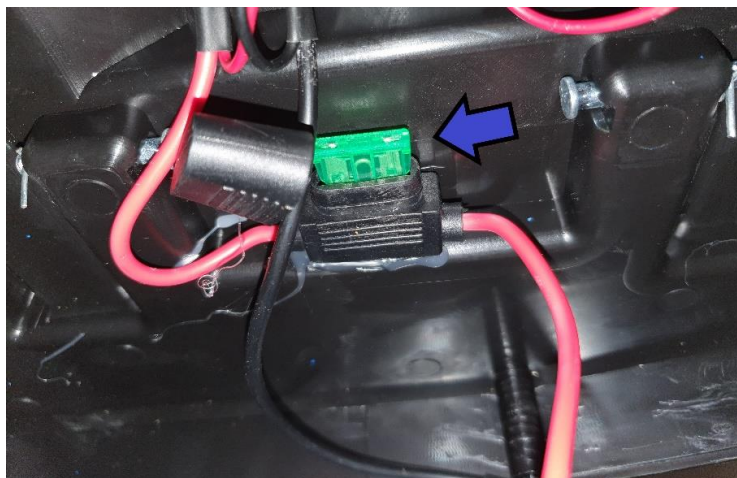

PRE-RIDE CHECKLIST

Loose Parts

Check and secure all fasteners before every ride. Make sure steering stem clamp bolts are locked properly in place. There should not be any unusual rattles or sounds from loose parts or broken components. If you are not sure, ask an experienced mechanic to check.

Brake

Check the brake for proper function. When you squeeze the lever, the brake should provide positive braking action. When you apply the brake with the speed control on, the brake cut-off switch will stop the motor.

Frame, Fork and Handlebars

Check for cracks or broken connections. Although broken frames are rare, it is possible for an aggressive driver to bash into a curb or wall and wreck and bend or break a frame. Get in the habit of inspecting yours regularly.

Tire Inflation

Periodically inspect the tires for excess wear, and regularly check the tire pressure and re-inflate as necessary. If you get a flat tire, the inner tube can be patched or a new tube can be purchased from Razor or an authorized repair center.

Safety Gear

Always wear proper protective equipment such as an approved safety helmet, elbow pads and kneepads. Always wear shoes (lace-up shoes with rubber soles), never drive barefooted or in sandals, and keep shoelaces tied and out of the way of the wheels, motor and drive system

REPAIR AND MAINTENANCE

Turn power switch off before conducting any maintenance procedures.

Adjusting the Brake

The mini quad is with 2 front brake and 1 rear brake.

WARNING: The brake is capable of causing the electric mini quad to skid the tire throwing an unsuspecting rider. Practice in an open area free from obstacles until you are familiar with the brake function. Avoid skidding to a stop as this can cause you to lose control or damage the rear tire.

The front & rear brake settings are adjusted with a cable clamp.

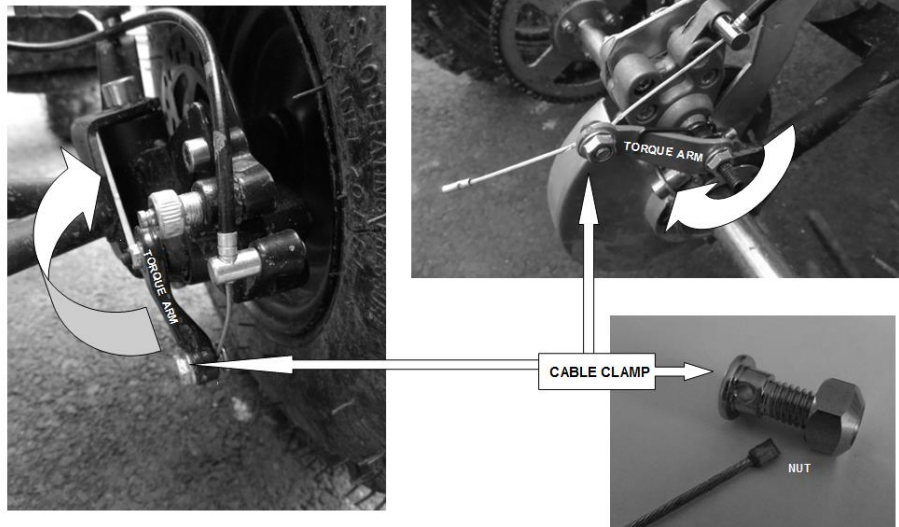

Loosen the nut, hold the cable in position and adjust the torque arm by rotating it according to the tightening requested, tight the nut with 10mm spanner when it's adjusted.

REPAIR AND MAINTENANCE

□ Adjusting the chain

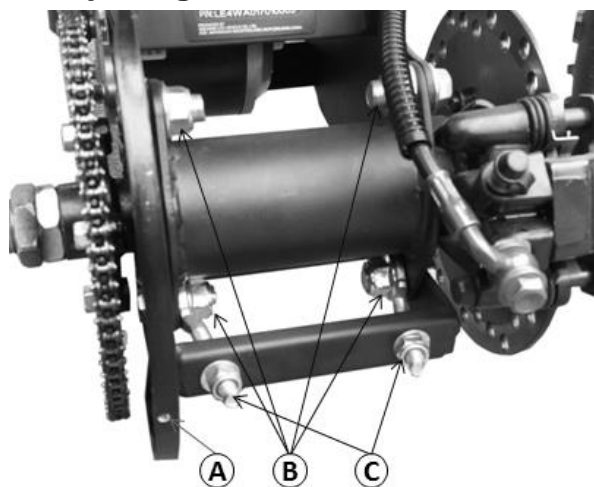

1. loosen the 4pcs nut (B)
2. loosen the screw (A) and press the plastic buckle to remove the chain cover.
3. loosen the chain adjuster nut (C), adjust the chain properly (refer to the standard: chain can move freely up and down about 4mm), then fasten the nut (C) and (B)

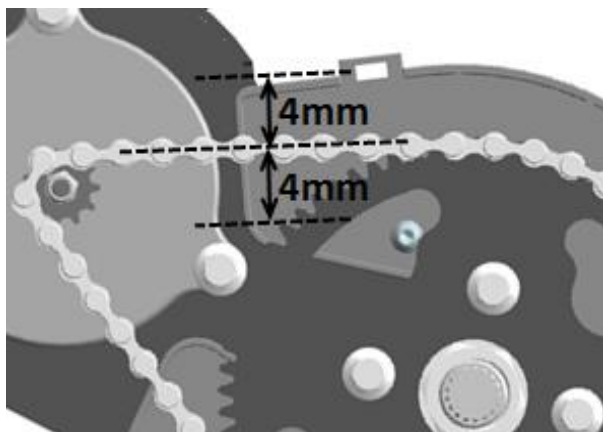

□Chain and Sprocket

The chain will typically have a “loose spot” and “tight spot” corresponding with a particular sprocket rotational position. This is normal and common to all chain-driven vehicles due to run-out tolerances of the freewheel and sprocket. Proper chain alignment must be maintained. If the chain is noisy or rough running, check the lubrication, tension and alignment of the sprockets, in that order. The tensioner arms must be aligned and free from binding and the tensioner spring(s) must be operating correctly.

Warning:

To avoid a pinch or injury, keep fingers away from moving sprockets and chain

□Battery Care and Disposal

Do not store the battery in temperatures above 75° F or below -10° F.



CONTAINS SEALED LEAD BATTERY. BATTERY MUST BE RECYCLED.

Disposal: Your product uses sealed lead-acid batteries which must be recycled or disposed of in an environmentally sound manner. Do not dispose of a lead-acid battery in a fire. The battery may explode or leak. Do not dispose of a lead-acid battery in your regular household trash. The incineration, land filling or mixing of sealed lead-acid batteries with household trash is prohibited by law in most areas. Return exhausted batteries to a federal or state approved lead-acid battery recycler or a local seller of automotive batteries.

Warning:

If a battery leak develop, avoid contact with the leaking acid and place the damaged battery in a plastic bag. Refer to the disposal instructions above, if acid comes into contact with skin or eyes, flush with cool water for at least 15 minutes and contact a physician.

Warning:

Battery posts, terminals and related accessories contain lead and lead compounds.

Wash hands after handling.

□ Charger

The transformer/charger supplied with the product should be regularly examined for damage to the cord, plug, enclosure and other parts, and, in the event of such damage, the Mini Quad must not be charged until it has been repaired or replaced.

Use ONLY with the recommended charger.

WARNING: To avoid a pinch or injury, keep fingers away from moving sprockets and chain.

WARNING: If a battery leak develops, avoid contact with the leaking acid and place the damaged battery in a plastic bag. Refer to the disposal instructions as above. If acid comes into contact with skin or eyes, flush with cool water for at least 15 minutes and contact a physician.

TROUBLESHOOTING GUIDE

Problem	Possible cause	Solution
Vehicle does not run.	Undercharged battery.	Charge the battery. A new battery should have been charged for at least 12 hours before using the vehicle for the first time and up to 8 hours after each subsequent use.
		Check all connectors. Make sure the charger connector is tightly plugged into the charging port, and that the charger is plugged into the wall.
		Make sure power flow to wall outlet is on.
	Charger is not working.	You may check to see if your charger is working by using a volt meter or asking the authorized service center to test your charger for you.
Vehicle was running but suddenly stopped.	Loose wires or connectors.	Check all wires and connectors to make sure they are tight.
	Burned-out fuse.	The fuse will burn out and automatically shut off the power if the motor is overloaded.
		An excessive overload could cause the motor to overheat. Refer to replacing the fuse instructions of this manual. Correct the conditions that caused the fuse to burn out and avoid repeatedly burning out fuse.
Motor or electrical switch damage.	Contact the authorized service center for diagnosis and repair.	
Short run time less than 15 minutes per charge	Undercharged battery	Charge the battery. A new battery should have been charged for at least 12 hours before using the vehicle for the first time and up to 8 hours after each subsequent use.
		Check all wires and connectors. Make sure the battery connector is tightly plugged into the charger connector, and that the charger is plugged into the wall.
		Make sure power flow to the wall outlet is on.
	Battery is old and will not accept full charge.	Even with proper care, a rechargeable battery does not last forever. Average battery life is 1 to 2 years depending on vehicle use and conditions. Replace only with a replacement battery.
Brakes are not adjusted properly	Refer to brake adjustment instructions.	

Vehicle runs Sluggishly.	Driving conditions are too stressful.	Use only on solid, flat clean and dry Surfaces such as pavement or level ground.
	Tires are not properly Inflated.	The tires are inflated when shipped, but They invariably will lose some pressure Between the point of manufacturing and your purchase. Refer to tire instructions to properly inflate tires.
	Vehicle is overloaded.	Make sure you do not overload the vehicle by allowing more than one rider at one time, exceeding the maximum weight limit, going up too steep a hill or towing objects behind the vehicle. If the vehicle is overheated, the temperature circuit protector will slow motor down and if the condition continues, will shut off power to the motor. Correct the driving conditions that caused the overheating, wait 5-10 minutes and then resume riding. Avoid repeatedly overheating the unit.
Sometimes the vehicle doesn't run, but other times it does.	Loose wires or connectors	Check all wires around the motors and all connectors to make sure they are tight.
	Motor or electrical Switch damage.	Contact the authorized service center for diagnosis and repair.
Charger gets warm During use	Normal response to Charger use	No action required. This is normal for some Chargers and is no cause for concern. If your charger dose not get warm during use, it does not mean that it is not working properly.
Vehicle does not Stop when applying the brake.	Brakes are not adjusted properly	Refer to brake instructions to properly adjust Brakes.
Vehicle makes loud noises or grinding sounds	Chain is too dry	Apply a lubricant to the chain.

CIRCUIT DIAGRAM

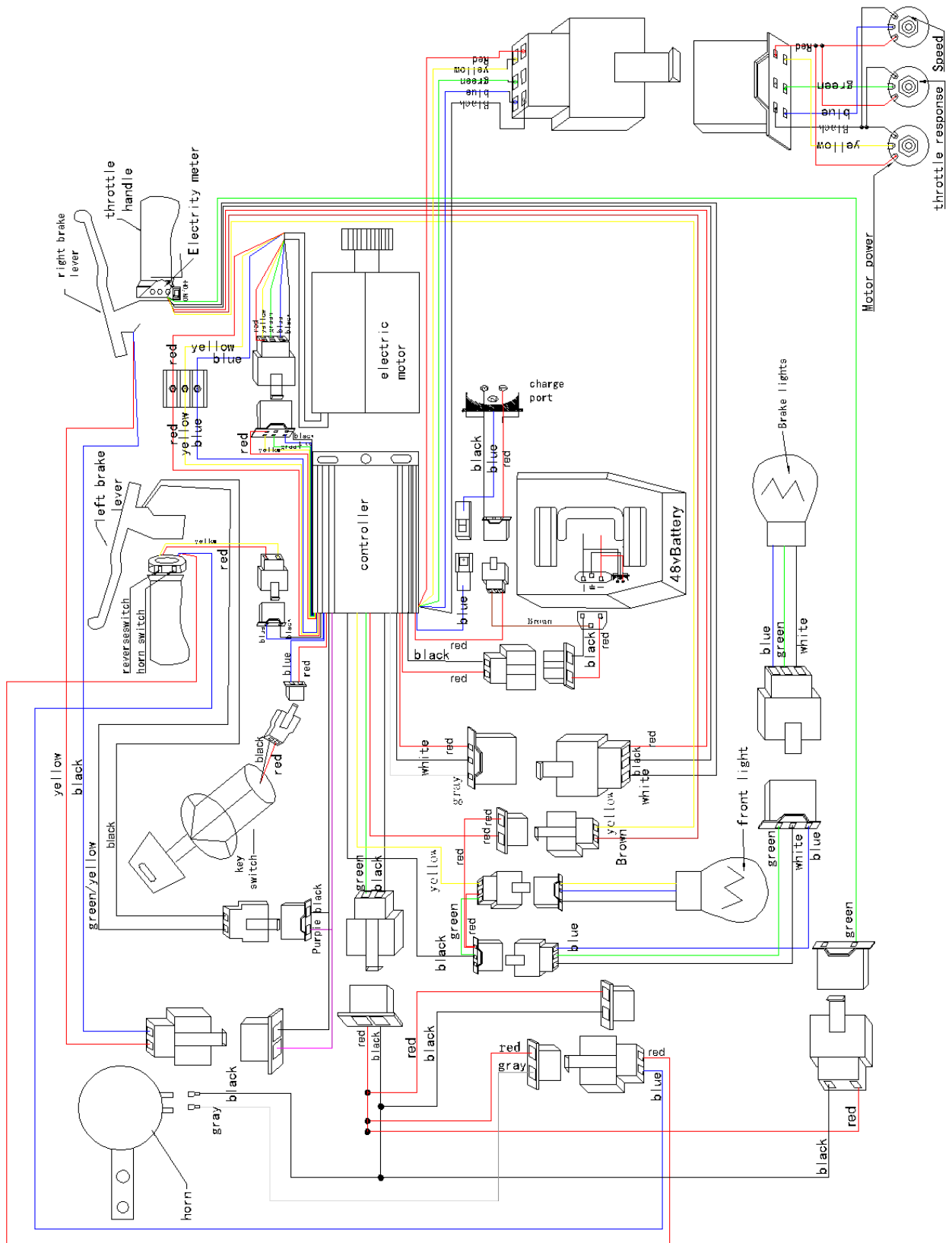



Please read the owner's manual before riding.



Never operate this vehicle if you are under age 12.



Never use the vehicle on public road. OFF ROAD use only.



Never ride with a passenger



Always use an approved helmet and protective gear



NEVER use with drugs or alcohol



Cold tire pressure.